

Installation Instructions

DTC-24 SNOW MELTING & ROOF DE-ICING CONTROLS



DTC-24R Roof and Gutter
De-icing or Snow Melting Control



DTC-24S Roof and Gutter
De-icing or Snow Melting Control



DTC-24A Roof and Gutter
De-icing or Snow Melting Control

CONTENTS	page
SECTION 1. OVERVIEW	
1.1 Precautions	2
1.2 Base model components	2
1.3 General accessories.....	2
1.4 Operation	2
SECTION 2. INSTALLING	
2.1 Installing the DTC-24 control panel	3
2.2 Electrical connections	3
2.3 Electrical connections	4
2.4 Installing the RG roof sensor	6
2.5 Installing the MP slab sensor	7
2.6 Installing the MMP sensor	8
2.7 Installing the RID.....	9
SECTION 3. PROGRAMMING	
3.1 LED display settings.....	10
3.2 Programming setpoint temps and alarms.....	11
3.3 LED screen alarm displays and resetting alarms	11
3.4 Locking the keypad.....	13
SECTION 4. TESTING AND TROUBLE SHOOTING	
4.1 Maintenance.....	14
4.2 System function test	14
4.3 Trouble shooting and Technical Support.....	14

Section 1. Overview

1.1 PRECAUTIONS

- Installation must comply with local electrical codes.
- All related components and this control should be properly rated for the specified location classification.
- The control must be installed by a qualified electrician.
- The DTC-24 control panel enclosure is rated NEMA 4X.

1.2 BASE MODEL COMPONENTS

DTC-24R	DTC-24S	DTC-24A
(1) DTC-24 Control Panel	(1) DTC-24 Control Panel	(1) DTC-24 Control Panel
(1) RG Sensor	(1) MP Sensor	(1) MMP

1.3 GENERAL ACCESSORIES

Accessories

Product Number	Description
RGS*	Secondary gutter mounted moisture sensor for DTC-24R or DTC-24S
SMP*	Secondary slab mounted sensor for DTC-24S
SMMP*	Secondary aerial mounted moisture sensor for DTC-24A
R.I.D.	Remote indication and activation timer
MPSWP-50	plenum rated six conductor #22 AWG sensor extension wire

* Note: Wire secondary sensors (RGS, SMP, or SMMP) in parallel with primary sensor. Connections to be made in appropriately rated junction boxes.

1.4 OPERATION

The DTC-24 is intended to control heating cable in the application of slab snow melting or roof and gutter de-icing. The DTC-24 control panel provides low voltage for an external slab or gutter sensor(s), and/or RID (remote indication and activation timer).

The snow melting or roof de-icing system will activate when the following two conditions are met:

1. The slab/ambient temperature is less than the setpoint temperature [typically 40°F (4.4°C)].
2. Snow or moisture is present on the moisture sensor.

The snow melting or roof de-icing system will deactivate when one of the following conditions are met:

3. No moisture is present on the sensor and the countdown timer has finished (preset "on" time with sensor dry).
4. When ambient or slab temperature exceeds the setpoint temperature.

The snow melting or roof de-icing system remains deactivated until the two activation conditions reoccur.

- Installation must comply with local electrical codes.
- All related components and this control should be properly rated for the specified location classification.
- The control must be installed by a qualified electrician.
- The DTC-24 control panel enclosure is rated NEMA 4X.

Section 2. Installation

2.1 INSTALLING THE DTC-24 CONTROL PANEL

The DTC-24 control panel can be installed outdoors or indoors. Mount the DTC-24 control panel as shown in Detail 1.

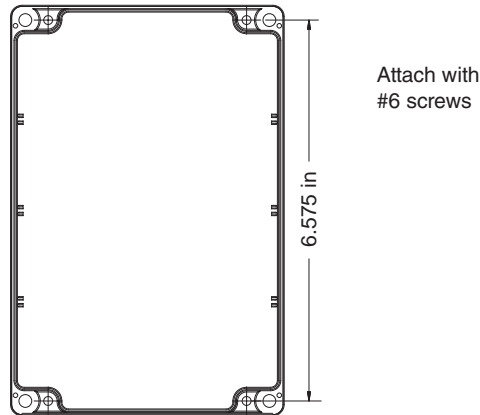

Detail 1. Installing DTC-24 control panel.

2.2 ELECTRICAL CONNECTIONS

1. Connect cord grip or 1/2" (13mm) conduit for low voltage wiring to the DTC-24.
2. Connect 1/2" (13mm) conduit in the pre-punched hole on the bottom left and route low voltage wiring to the Power Control Panel with GFPE and 24 VAC/VDC source.

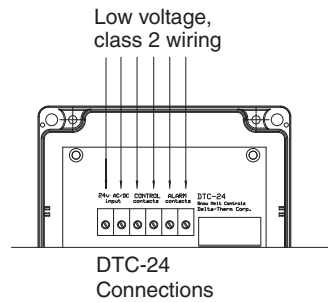

Detail 2. Electrical connections.

Section 2. Installation

2.2 ELECTRICAL CONNECTIONS

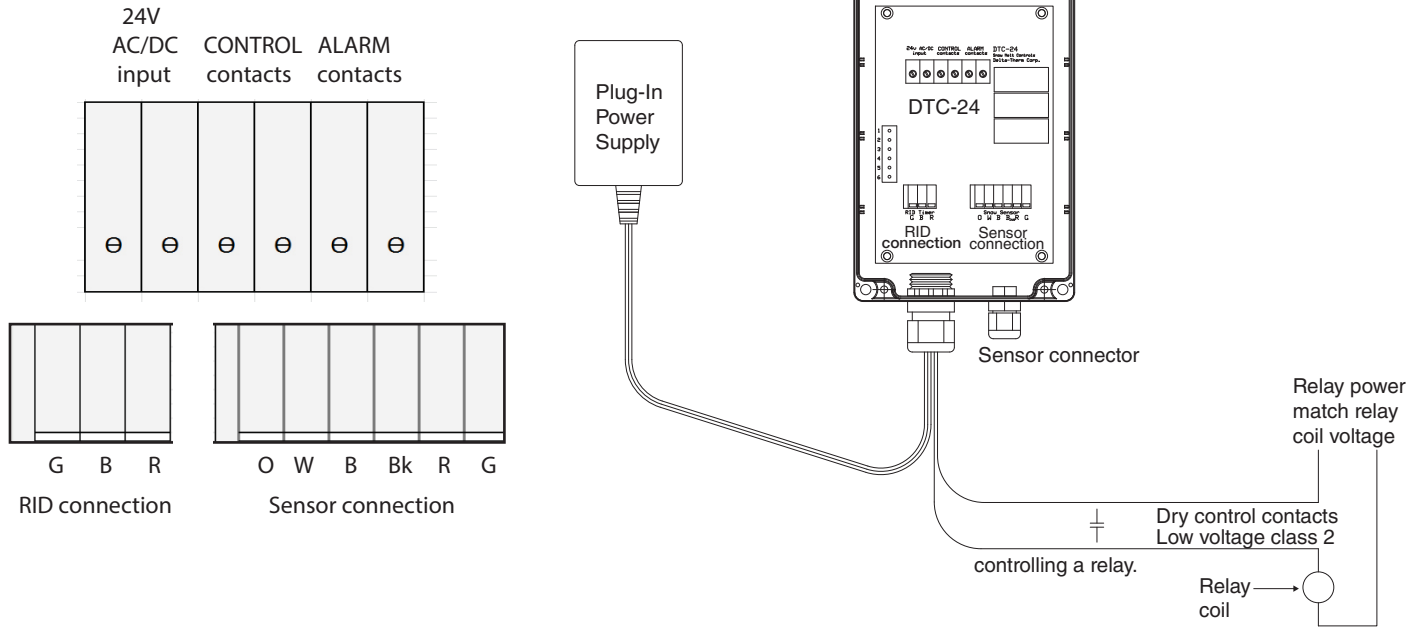

3 ELECTRICAL WIRING OF THE DTC-24
SM SCALE: NTS

Detail 3. Electrical wiring

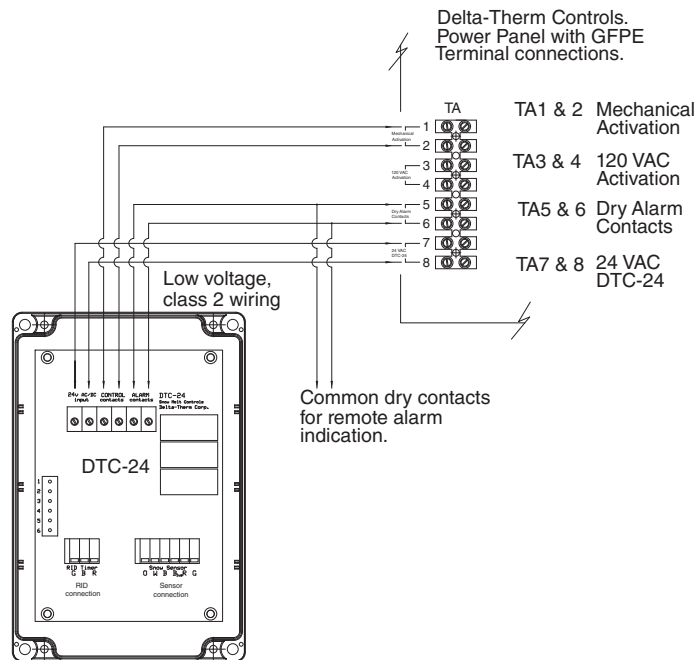

Detail 4. Electrical connection when Power Control panel with GFPE is switching load.

Section 2. Installation

2.3 ELECTRICAL CONNECTIONS WHEN POWER CONTACTOR PANEL WITH GFPE IS SWITCHING LOAD

1. Connect 1/2" (13mm) conduit for low voltage in the pre-punched hole on the bottom right of the control panel.

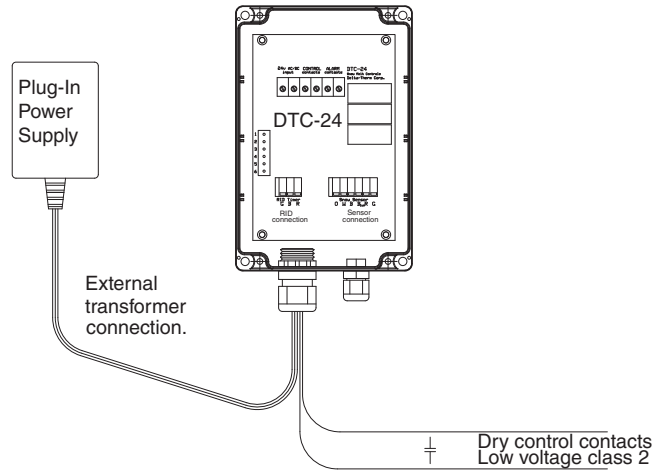

Detail 5. Electrical connection when contactor panel is switching load.

Detail 5. Electrical wiring when contactor panel is switching load.

Section 2. Installation

2.4 INSTALLING THE RG ROOF SENSOR

1. Place the RG sensor in the gutter using half of the supplied double-sided adhesive pad, directly under a drip loop. Do not locate the RG sensor under trees, awnings, next to a structure, or in any location which may be blocked from snow.
2. The DTC-24 can be provided with the RG sensor attached to the DTC-24 control panel with approximately 10' (3.04m) of sensor wire. To lengthen or shorten the sensor wire (press on the top of the terminal to release/insert wire):
 - Remove the six conductors of the sensor wire from the terminal block inside the control panel and loosen the sensor wire connector.
 - Gently pull the sensor wire through the wire connector and either cut to length as needed or splice on additional extension sensor wire in an appropriate junction box.*
 - Gently pull sensor wire back through the wire connector and reconnect the six conductors to the terminal block.
3. Wrap the remaining half of the adhesive pad around the Thermistor. The pad should adhere to itself. Stick the thermistor to the upper inside edge of the gutter. Do not allow the thermistor to touch the heating cable or any other heat source.

*NOTE: Select appropriate rated wire if exposed to sunlight (UV Inhibited) or route through a plenum air space.

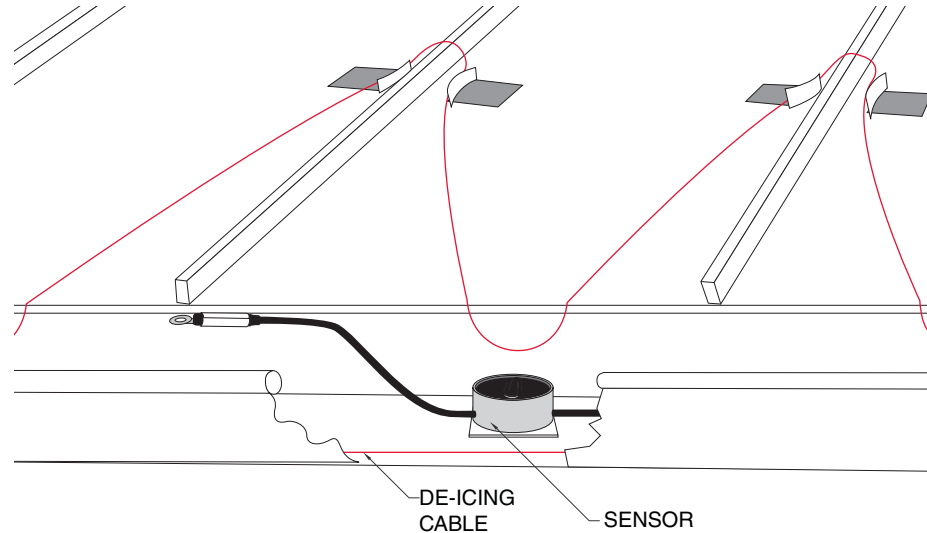

Detail 6. Installing the RG sensor in the gutter

Section 2. Installation

2.5 INSTALLING THE MP SLAB SENSOR

The MP sensor is mounted flush with the heated surface in an area most indicative of snow conditions. Do not locate the MP sensor under trees, awnings, where cars are parked, next to a structure, or in any location which may be blocked from snow.

The DTC-24 can be provided with an MP sensor. Attach to the DTC-24 control panel with approximately 10' (3.04m) of sensor wire. To lengthen or shorten the sensor wire (press on the top of the terminal to release/insert wire):

- Remove the six conductors of the sensor wire from the terminal block inside the control panel and loosen the sensor wire connector.
- Gently pull the sensor wire through the wire connector and either cut to length as needed or splice on additional extension sensor wire in an appropriate junction box.*
- Gently pull sensor wire back through the wire connector and reconnect the six conductors to the terminal block.

*NOTE: Select appropriate rated wire if exposed to sunlight (UV Inhibited) or route through a plenum air space

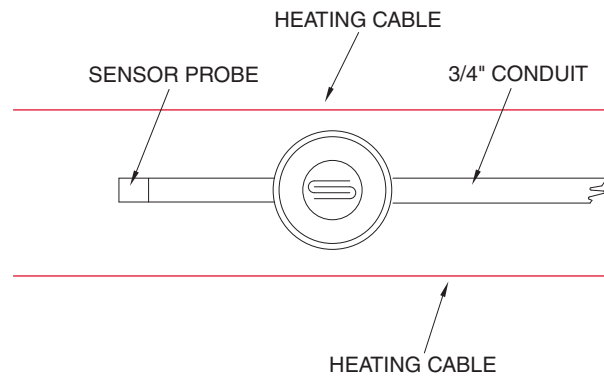

Detail 7. Plan view of a slab sensor.

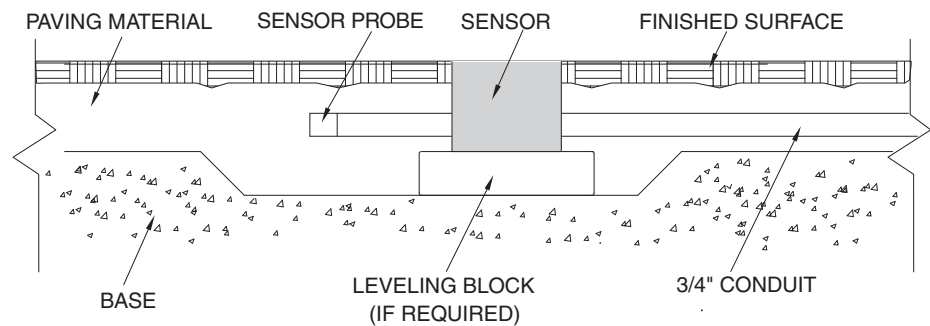

Detail 8. Side view of slab sensor.

Section 2. Installation

2.6 INSTALLING THE MMP SENSOR

1. Place the MMP sensor in the gutter or an area most indicative of snow conditions. Do not locate the MMP sensor under trees, awnings, next to a structure, or in any location which may be blocked from snow.

The MMP sensor can be attached to a junction box using the supplied .75" (19.05 mm) PVC conduit connector.

2. The DTC-24 can be provided with the MMP sensor attached to the DTC-24 control panel with approximately 10' (3.04m) of sensor wire. To lengthen or shorten the sensor wire (press on the top of the terminal to release/insert wire):
 - Remove the six conductors of the sensor wire from the terminal block inside the control panel and loosen the sensor wire connector.
 - Gently pull the sensor wire through the wire connector and either cut to length as needed or splice on additional extension sensor wire in an appropriate junction box.*
 - Gently pull sensor wire back through the wire connector and reconnect the six conductors to the terminal block.

*NOTE: Select appropriate rated wire if exposed to sunlight (UV Inhibited) or route through a plenum air space.

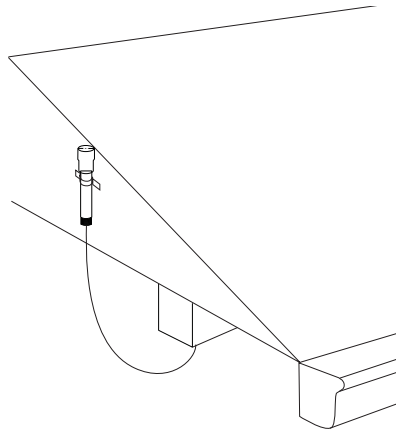

Detail 9. Installing the MMP sensor at roof level.

Section 2. Installation

2.7 INSTALLING THE RID

1. Drill a hole for cord grip or a .5" (12.7mm) conduit fitting in the DTC-24 enclosure.
2. Install low voltage three conductor cable or the .5" (12.7mm) conduit from the DTC-24 to the RID junction box.
3. Install a low voltage three conductor cable or three insulated wires (22 awg minimum) from the DTC-24 to the RID via the conduit.
4. Connect the red, green, and black wires of the RID to the R (red), G (green), and B (black) terminals of the DTC-24 via the three installed conductors.

NOTE: The RID indicates de-icing/snow melting system activation and can communicate with the DTC-24 to switch on the de-icing/snow melting system via the approximate 75 minute or 5 hour timer setting with the jumper on the back of the RID.

If the de-icing/snow melting system is activated by the sensor communicating with the DTC-24, the RID cannot override the DTC-24 to switch the de-icing system off.

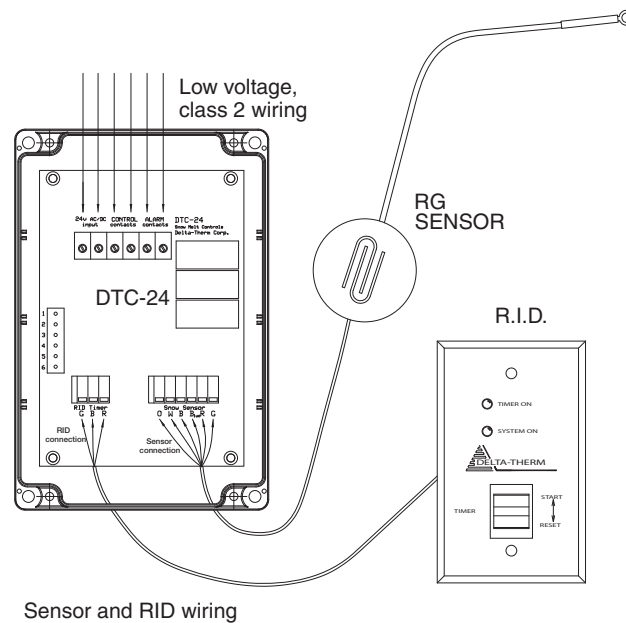

Detail 10. Installing the RID.

Section 3. Programming

3.1 LED DISPLAY SETTINGS

The banner heading "Delta-Therm Corp Heat Trace CTL" is displayed after applying power to the control panel. After the banner heading is displayed the LED screen will display the temperature as detected by the RTD and the control panel setpoint temperature.

If the keypad is locked-out, move the red dipswitch on the inside enclosure door into the enable position.

FACTORY DEFAULT SETTINGS:

Setpoint Temperature = 40°F

With sensor dry continue: 2 hrs.

Temperature cannot be set lower than 0°F.



Detail 11. Display message upon first applying power to the control panel. This will display for a few seconds only.

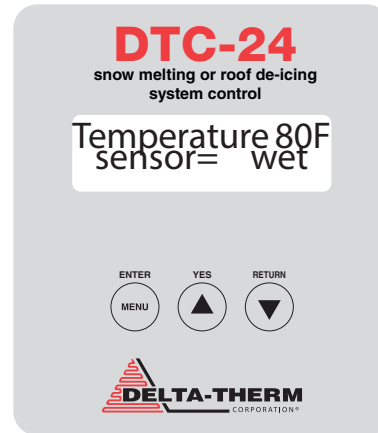

Detail 12. Default display message, temperature as detected by the RTD and control panel setpoint. After a few seconds the display will switch setpoint = 40F to display sensor = wet or dry.

Section 3. Programming

3.2 PROGRAMMING SETPOINT TEMPERATURE AND COUNT DOWN TIMER

There are three dual purpose selector push-buttons: “ENTER/MENU”, “YES/arrow pointed up” (referred to as “YES/up”), and “RETURN/arrow pointed down” buttons (referred to as “RETURN/down”). The parameters can be accessed in the following order:

1. To access parameters: Press the “ENTER/MENU” button for up to 4 seconds and the LED screen will display: “Set-up & reset”. Remove finger and wait for the “Setpoint=40F” message to display.



Detail 13. The set-up and reset message will display after pressing and holding the “ENTER/MENU” for approx. four seconds.

2. To enter or change the setpoint temperature: Press “YES/up” arrow button and the LED screen will display: “Setpoint = 40F” (Setpoint = 40F is the default setting). Temperature cannot be set lower than 0°F.
3. Press the “YES/up” arrow button to raise the setpoint temperature. Press the “RETURN/down” arrow button to lower the setpoint temperature.
4. When the LED screen displays your setpoint temperature press the “ENTER/MENU” button and “With sensor dry continue: 2hrs.” will display.

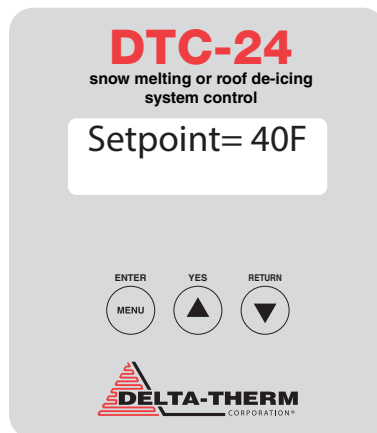

Detail 14. Press the “YES/up” arrow button to raise setpoint temperature. Press the “RETURN/down” arrow button to lower setpoint temperature. Press ENTER/MENU button to move on to next parameter.

Section 3. Programming

3.2 PROGRAMMING SETPOINT TEMPERATURE AND COUNT DOWN TIMER

5. To enter the countdown time: After the “With sensor dry continue: 2hrs.” is displayed you can change the count down timer setting from 0 hours to 24 hours. Press “YES/up” arrow button to raise the count down timer up to 24 hrs. Press the “RETURN/down” arrow button to lower the count down timer down to 0 hrs. Press “ENTER/MENU” button to accept the new time duration.



Detail 15. Press the “YES/up” arrow button to raise the Count Down Timer up to 24 hours. Press the “RETURN/down” arrow button to lower the Count Down Timer down to 0 hours. Press ENTER/MENU button to move on to next parameter.

6. The LED screen will display “System Reset?”. Press the “RETURN/down” arrow button to save the settings.



Detail 16. When the System Reset? message is displayed, press the “RETURN/down” arrow button to save settings.

Section 3. Programming

3.3 LED SCREEN ALARM DISPLAYS AND RESETTING ALARMS

The “Sensor wire fail” message will display if either of the blue or black sensor wires are open, the sensor heater fails, or the red and green sensor wires are shorted. Please refer to Section 4.3 Trouble shooting and technical support.

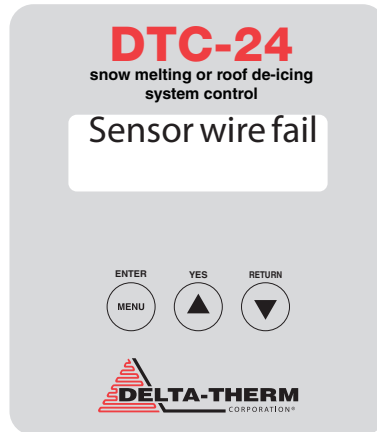

Detail 17. The “Sensor wire fail” message.

3.4 LOCKING THE KEYPAD

A red dipswitch, labeled enabled/disabled input, is located on the inside of the enclosure door. Move the dipswitch into the left position to enable the keypad. Move the dipswitch into the right position to disable the keypad.

Section 4. Trouble-Shooting And Technical Support

4.1 MAINTENANCE

Clean the surface of the sensor before the start of each heating season with a brush or other means to remove dirt, grime, leaves, or debris that obstructs contact with snow or ice. Perform the system function check before the start of each heating season.

4.2 SYSTEM FUNCTION TEST

1. Confirm all wiring is complete per wiring diagrams.
2. Ensure that power wiring will not be applied to any snow melting cable that is not embedded in concrete, asphalt, or in a crushed rock bed under pavers. Ensure that all the roof and gutter de-icing cable is terminated per manufacturer's instructions.
3. Apply 24 VAC or 24 VDC to the DTC-24. The "Delta-Therm Corp, DTC-24 Control" banner will be briefly displayed.
4. The display will show the temperature at the sensor and alternate the temperature setpoint with the moisture status of the sensor.
5. To test the system you 1) raise the temperature setpoint above the temperature shown for the sensor. The maximum settable temperature is 100°F for warm weather testing. 2) Set the sensor dry countdown to 0 as detailed in the programming instructions.
6. Pour water on the sensor, the display will show "Moisture Sensed, System On", and alternate with the temperature and setpoint screen.
7. This activation will close the dry control contacts on the DTC-24 circuit board. This can be used as a single pole switch for the coil voltage on a contactor or relay. Verify the power controlling device has been activated.
8. Dry the sensor to deactivate the system. Confirm the power controlling device has also deactivated.
9. Re-enter set-point and the sensor dry countdown timer.
10. If using an RID device, confirm system activation and deactivation using the RID up/down toggle switch and LED indicator lights.

4.3 TROUBLE-SHOOTING AND TECHNICAL SUPPORT

Display does not turn on	<ul style="list-style-type: none"> - Check 24 vac or vdc voltage at terminals - Check connector on display - Check connector wiring - Check for damage
Keypad does not respond	<ul style="list-style-type: none"> - Check enable/disable switch - Check connector wiring
Sensor is dry though display says wet or sensor is wet though display says dry	<ul style="list-style-type: none"> - Check sensor wiring/splices - Replace sensor
Air temperature is different than shown on display	<ul style="list-style-type: none"> - Sensor in direct sunlight - Sensor is showing slab temperature - Sensor is in contact with warm object - Incompatible sensors used - Temperature accuracy is less below 30°F
Sensor wire fail shown on display	<ul style="list-style-type: none"> - Check splices and wire for damage - Replace sensor
DTC-24 does not activate power panel	<ul style="list-style-type: none"> - Check wiring - Check power panel is operational - DTC-24 control contacts are dry, to be used as a single pole switch
RID control is not shown on display	<ul style="list-style-type: none"> - Only shown when DTC-24 control is not controlling the power panel
System operates after snow is removed	<ul style="list-style-type: none"> - Reduce countdown timer appropriately

For additional Trouble-Shooting Procedures, please contact Delta-Therm Technical Support for DTC-24 Trouble-Shooting Manual.

If you have any questions or comments about these instructions, or your installation please call Delta-Therm between the hours of 8:00 a.m. - 5:30 p.m. CST, Monday through Friday at 1-800-526-7887.