

INSTALLATION, PARTS, SERVICE & MAINTENANCE MANUAL FOR HLA SERIES HEATER

Electric Air Heaters for Hazardous Locations

Divisions 1 & 2
Class I Group C, D - Class II, Groups E, F & G

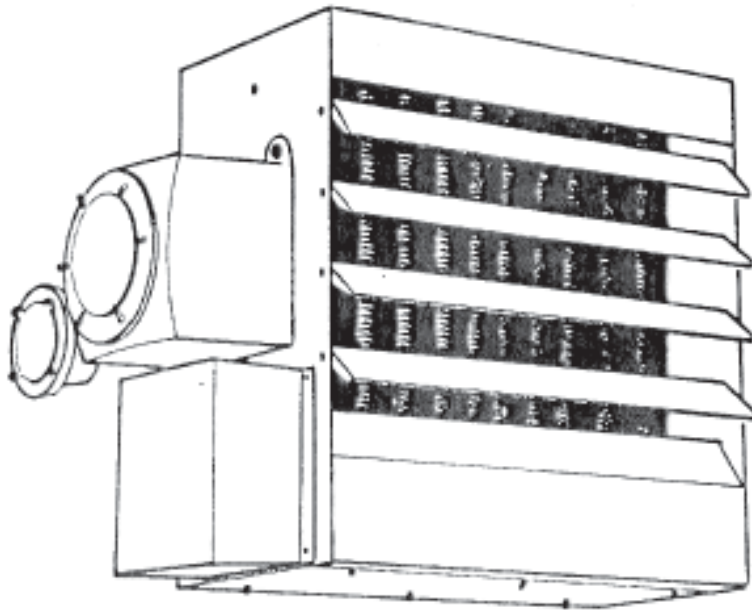

Models covered by this manual:

HLA12 - 3, 5 AND 7.5 KW

HLA16 - 10 KW

HLA20 - 15, 20 AND 25 KW

WARNING!

READ ALL WARNINGS AND NOTICES.

WARNING

To prevent ignition of hazardous atmospheres adhere to the following:

1. Read and follow the instructions in this manual.
2. The HLA Series electric unit heaters have been listed by the Underwriters Laboratories and have a maximum operating temperature of 165°C. DO NOT install heaters where the marked operating temperature exceeds the ignition temperature of the hazardous atmosphere.
3. Before opening any enclosure, first disconnect the heater from the power supply.
4. It is absolutely essential that the high-limit thermostat provided in the heater be left in operation. Never bypass the high-limit from the contactor coil circuit. When installing an external control thermostat, connect it to the terminal block provided in the control box. Refer to "INSTALLATION - ELECTRICAL" for more details.
5. Operate heater only while permanently mounted in an upright position. See "INSTALLATION - MECHANICAL" for tilt limits.
6. To operate correctly, the heater must be kept clean. When operating in a dirty environment, regularly clean the finned tubes, fan and fan guard, and motor cooling fan, if provided.
7. If any fluid leakage occurs, withdraw the heater from service and have it repaired. See "REPAIR AND REPLACEMENT PROCEDURES - HEAT EXCHANGER CORE" for details.
8. Never operate the heater with all or any louvers fully closed. Set all louvers to similar angles to obtain required air flow direction. Stops have been provided in the cabinet side walls to limit the amount to which the louvers may be closed. DO NOT OVERRIDE THESE STOPS.
9. Do not operate in atmosphere corrosive to steel and aluminum.
10. During installation, ensure that the 1" plastic protector cap in the control box is discarded and replaced with either an incoming conduit or the remaining 1" explosion-proof plug not being used. Do not operate the heater without proper explosion-proof plugs installed in all unused threaded openings.

WARRANTY WILL BE VOIDED IF THESE WARNINGS ARE NOT ADHERED TO.

INTRODUCTION

APPROVED SERVICE USES

HLA Series Electric Air Heaters for Hazardous Locations are U.L. listed for use in hazardous locations Divisions 1 and 2, Class 1, Group C, D and Class II, Groups E, F and G. For details of the particular hazardous environments having the potential for explosion, refer to articles 500 through 516 of the National Electrical Code.

MODEL CODING

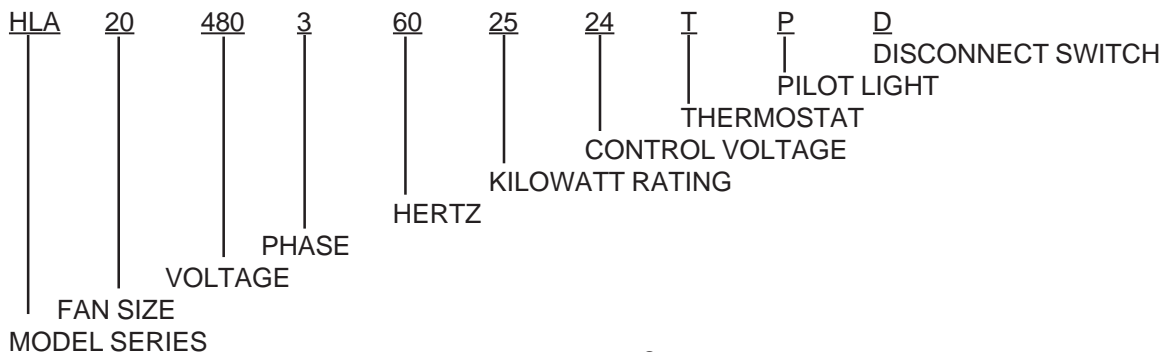

DESCRIPTION

The HLA Series heaters use a permanently sealed, liquid-to-air finned tube heat exchanger core. This consists of a bottom tank containing three immersion type heating elements and two rows of finned heat exchanger tubes welded between the bottom tank and a top header tank. A specific mixture of ethylene glycol to water mixture is placed in the heater core to act as the heat transfer fluid. Heat is transferred to the fluid mixture by the heating elements causing vigorous convective vapor circulation and condensation within the heater core, ensuring even heat distribution. The ethylene glycol provides freeze damage protection to -49°F (-45°C). An electric motor driven fan blows air over the finned tubes to transfer heat to the air flow, thus heating the area.

Over temperature protection is effected by a manual reset capillary type high-limit rated for 6,000 cycles of reliable service, which is housed in a thermowell tube next to the heating elements. Overpressure arising from excessive external temperature is relieved by a pressure relief valve provided in the top heater tank.

The heater core assembly is contained in a sturdy steel cabinet which also carries the controls, motor and fan assembly. A narrow gap safety fan guard is provided to shield all moving parts. Adjustable louvers are provided to allow directional control of the airflow.

All electrical power is carried by copper conductor wires enclosed in rigid metal conduits. Only within the enclosures are wires exposed to permit connection to terminals.

NOTE - In order to provide the highest possible outlet air temperatures, yet operate safely in hazardous atmospheres, these heaters operate in a narrow temperature band between normal operating temperature and that temperature at which the high-limit control shuts off to limit maximum temperature. It is probable therefore, that the heater will not operate continuously should ambient temperatures exceed 104°F (40°C).

INSTALLATION

MECHANICAL

The HLA series heaters are designed for use only while permanently mounted in an upright position. The supporting assembly must ensure that the heater is installed such that it operates in an upright attitude. The maximum out of plane attitude shall not exceed the values indicated in the following sketch.

To insure proper heating of floor surfaces, observe the following recommended maximum mounting heights (to

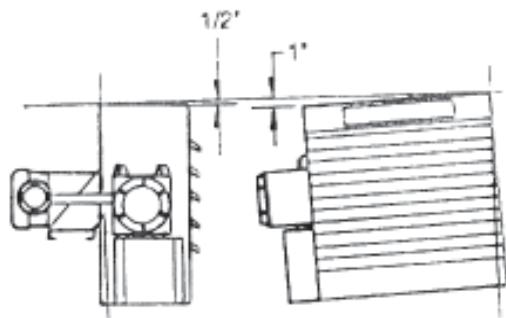

Maximum tilt allowed during operation (applicable front to back and side to side in either direction).
Heater must be permanently mounted.

Max Mtg. Height from Floor:	<u>HLA12</u> 8 ft.	<u>HLA16</u> 10 ft.	<u>HLA20</u> 13 ft.
-----------------------------	-----------------------	------------------------	------------------------

The heater should be installed to allow clearances for services access and air circulation as follows:

- Back - 2" from motor
- Front - 84" HLA20, 72" HLA12 & HLA16
- Right Side - 1"
- Left Side - 30" from control box
- Top - 0"
- Bottom - Cabinet height plus 6" (Optional - for easier core removal)

To permit removal of the heater core assembly from a suspended heater, leave space beneath the heater at least equal the cabinet height plus 6". Installations with less than specified clearances from the heater bottom make it necessary to dismount the entire unit should core removal be required.

It is essential that the supporting assembly be of adequate strength to suspend the heaters. See "Specifications" for heater weights. Adequate stiffness should be provided to ensure that unwanted vibrations or movements of the complete system do not occur. Such vibrations or movement could be induced by electric motor start-up, or be transmitted to the heater from the structure to which it is mounted, as in mobile installations. Where heaters are installed in applications that are of a relocatable or transportable nature (such as drilling rigs) design the mounting structure to withstand all probable load conditions. Such load conditions should recognize abuse situations such as truck off-loading impacts. The heaters should be suspended from the supporting assembly by two 5/8 NC bolts fitted with lock washers.

ELECTRICAL

The HLA heaters have been designed for explosion proof service, with single and three-phase inputs of 208, 240, 480 or 600 volts. They meet stringent U.L. requirements. However, it is essential that correct installation procedures be followed to eliminate all potential hazards arising from faulty installation.

Follow these instructions:

1. Should it be deemed desirable to install a room temperature control thermostat, refer to the appropriate electrical wiring diagram and follow these steps:

Remove the jumper wire from the small terminal block marked C1-C2 located in control enclosure. Connect the external thermostat to these terminals. The external thermostat will then be connected in series with the heater high limit and correct operation of the heater will result.

Any room thermostat used with these heaters must be of an explosion-proof type, open on temperature rise, suitable with control voltage selected.

WARNING

It is imperative that the high-limit (in the heater core junction box enclosure) remain connected in series with the room thermostat, the secondary output of the control transformer and the contactor coil. Under no circumstances are the heaters to be operated with the high-limit disabled or disconnected.

2. Proper installation of the heater requires that an adequate grounding conductor be connected to the ground terminal. This terminal is marked and is located in the control enclosure.
3. Avoid placing conduit runs directly beneath the heater in a way that would prevent removal of the heater core assembly.
4. On all 3-phase heaters, it is necessary to verify that the fan is rotating in the proper direction. If air delivery is not from the front of the heater, exchange any 2 input wires at the contactor. Do not needlessly remove the electric motor conduit box cover. In the event that the motor cover is removed, ensure that it is securely tightened when replaced.
5. Use only an approved explosion-proof means of wiring such as mineral insulated cable or copper conductors in rigid conduit to make connections to the heater.
6. External electric circuit breaker protection is required. See "TECHNICAL DATA" table and follow code recommendations. Check nameplate for voltage and amperage.
7. Follow all applicable electrical and building codes related to the intended use of the heater. Similarly, any National, State or Local codes must be observed and adhered to.
8. When doing any work on a heater, including the initial electrical connection, disconnect the electrical current at the main switch. Where possible lock the switch in the off (open) position and/or tag WARNING to prevent shock hazards.

9. Refer to the appropriate wiring diagram to ensure that all connections are as required and securely fastened.
10. Ensure conductors are of appropriate gauge size. Size all input conductors according to accepted standards consistent with the temperature rating of the wire being used. Use minimum 90°C rated wire. Minimum size for the thermostat circuit is 16 - AWG (90oC). Use copper conductors.
11. Ensure that input conductors and conduit have adequate strain relief at installation.
12. Confirm that the electrical power supply is compatible with the nameplate rating of the heater to be connected.
13. Before application of electrical power, recheck all connections to ensure compliance with the wiring diagram and any code requirements. Remove any foreign objects from the control box and reinstall cover lid tightly. Make certain that all three conduit box covers are securely in place.

MAINTENANCE RECOMMENDATIONS

CAUTION - Before undertaking any maintenance, disconnect the heater from the electrical power source. If possible, lock the main power switch in the off (open) position and/or tag to prevent shock hazards.

ELECTRICAL

Annually inspect all terminal connections, contactor and visible insulation for damage, looseness, fraying, etc. as applicable. Retighten any loose terminals and replace or repair damaged or deteriorated insulation. If contactor contacts are badly pitted, welded together or burned, replace the contactor. Check all explosion -proof conduit for visible damage and tightness. Contact TPI for replacement parts.

If reduced heat output is suspected, verify the condition of the heating elements by using an amperage meter to check the current draw of each input line. All input lines should draw approximately equal current which should agree with nameplate rating. If they do not, one or more of the heating elements could be burned out. See “REPAIR AND REPLACEMENT PROCEDURES”.

The electric motor is permanently lubricated and thermally protected. Check for smooth and quiet running at all inspections. Check shaft for bearing play. Replace motor if excessive bearing play is detected. Contact TPI for replacement parts.

MECHANICAL

Explosion-proof conduit boxes are designed with threaded joints and metal-to-metal contact at lid and cover joints to prevent an explosion. Do not attempt to install gasket materials of any type at these joints. A light coating of anti-seize compound is applied to the threads to prevent seizing.

Annually check the tightness of all visible bolts or nuts, in particular the support structure bolts and nuts. Similarly check the electric motor mounting bolts and nuts.

Periodically, depending on environmental service condition, check the cleanliness of motor, fan and heater core fins. Clean if required by air jet. Check louvers for tightness and equal angle settings. Check motor and fan for smooth running. Any unusual noise or vibration must be investigated and rectified.

REPAIR AND REPLACE PROCEDURES

CAUTION - Before undertaking any maintenance, disconnect the heater from the electrical power source. If possible, lock the main power switch in the off (open) position and/or tag to prevent shock hazards.

Should problems arise requiring repair or replacement of any major component, the following procedures should be followed where applicable:

HEAT EXCHANGER CORE

(Including HEAT TRANSFER FLUID, HEATING ELEMENTS and PRESSURE RELIEF VALVE)

The HLA Series heater core assemblies have been deliberately designed to permit only limited field service. Repair and overhaul is intended to only be by complete replacement of the core assembly with either a new or factory reconditioned core assembly. Such new or reconditioned core assemblies will be supplied with heating elements, pressure relief valve, the correct amount of fluid and a new high-limit. Each core assembly will have been factory assembled, inspected and electrically tested for correct heat output and proper operation of the high-limit. Because of the equipment and test procedures required to test core assemblies, it is not practical for cores to be field serviced. Incorrect field service procedures may render a heater potentially hazardous.

The only core assembly field service work sanctioned by the manufacturer is replacement of the capillary high-limit and cleaning.

To remove the heater core from the heater cabinet proceed as follows:

1. First remove all threaded and screw-attached sheet metal covers from the control box side of the heater. Then remove the bottom cover.
2. Remove all 5 wires from within the conduit between the upper and lower boxes.
3. The heater core assembly is secured by three 5/16 diameter x 1/2 capscrews; two on one side and one above the aluminum control box enclosure. Before removing these screws assistance will be required to support the weight of the core.
4. With a second person to support the weight of the core assembly, remove the three 5/16 diameter x 1/2 capscrews and have the helper carefully lower the heater core assembly from the cabinet.

HEAT TRANSFER FLUID

The heater cores are partially filled with an ethylene glycol/water solution similar to that used in automotive applications. Oral ingestion of this solution could prove fatal since ETHYLENE GLYCOL IS POISONOUS. Should ingestion occur, seek medical attention immediately.

Field service of the core assembly with respect to refilling it with fluid is not permissible. A new or factory reconditioned core assembly must be used and shall be provided by the manufacturer or one of its agents.

HEATING ELEMENTS

In the event of failure of the heating elements it will be necessary to replace the core assembly with a new or reconditioned unit.

PRESSURE RELIEF VALVE

The pressure relief valve is factory installed and pressure tested. Contact the manufacturer or authorized service agent should suspected problems occur.

ELECTRIC MOTOR

Remove the cover lid on the motor junction box and disconnect all the wires. Carefully loosen the union between the motor and control box enclosures. Loosen and remove the motor mounting bolts and fan guard bolts, being careful not to damage the fan blades. Note the relative axial position of the fan hub on the motor shaft and remove the motor mounting bolts and fan guard bolts, being careful not to damage the fan blades. Note the relative axial position of the fan blades. Note the relative axial position of the fan hub on the motor shaft and remove the fan.

To replace the motor, fan guard and fan assembly, reverse the above procedure. Position the fan on the shaft to the previously noted position. It is helpful to leave the motor bolts loose while connecting the union. The back of each fan blade should be about 3/4" from the inside of the fan guard. When everything is in place, make certain all fasteners are secure and that the conduits have at least 5 threads engaged. Manually spin the fan blade with a screwdriver before application of power to make certain it does not foul the cabinet or fan guard.

HIGH-LIMIT

The high-limit is rated for operation of 6,000 cycles. Experience indicates that nuisance tripping is generally not the fault of the high-limit but is usually caused by excessive input voltage, high ambient temperatures, or an excessively dirty heater core. The high-limit is unlikely to cause any difficulty, but if it should, follow these procedures:

Gain access to the high-limit by removing the sheet metal cover from the cabinet and the threaded aluminum cover from the core junction box. Once inside, pull off the two wires attached to the high-limit. Remove the two screws that retain the capillary high-limit and withdraw it by pulling.

To replace the high-limit, reverse the above procedure. Reconnect the thermostat wires on terminals. **DO NOT OMIT THIS OPERATION AND DO NOT BYPASS.**

Never use any replacement high-limit other than one supplied by the manufacturer as the heaters may be rendered potentially hazardous.

CONTROL TRANSFORMER

HLA heaters are provided with multi-tap primary transformers on 208, 240 and 480 volt models. If replacement is necessary, select the voltage tap compatible with the line voltage of the unit and cap off all unused taps. All 600 volt units are furnished with non selectable dedicated primaries.

NOTE: Transformers secondaries should not be sparked or shorted as they may be provided with embedded over current protection.

CONTACTOR

A contactor should be replaced if excessive pitting or burning of the contact points is found, or if the coil has burned out. (Note-the contactor is rated for 100,000 cycles of operation at it full rated capacity).

REPLACEMENT PROCEDURES - CONTROLS

BEFORE OPENING ANY ENCLOSURE, DISCONNECT HEATER FROM POWER SUPPLY.

Remove top plate located in control enclosure, by removing three (3) No. 8 screws. One of the screws also retains the grounding lug. Associated wiring must be removed from control block, fuse block, and contactor. Remove three (3) screws that retain the contactor mounting plate. Remove contactor mounting plate, which will have two standoff posts and contactor assembled as a unit. The contactor can be replaced if necessary, at this time.

If transformer or thermostat is to be replaced, remove three (3) screws retaining the plate on which they are mounted. Both parts will be removed together. If a thermostat is provided, the operating shaft must be withdrawn through its clearance hole or shaft hub screw loosened to free assembly. Transformer can now be replaced.

To replace thermostat, loosen bulb retaining clamps, and remove capillary plug retaining ring located on outside of enclosure. Withdraw thermostat and its capillary bulb through enclosure opening. Thermostat may be replaced at this time. When reassembling thermostat, retaining rings should be firmly seated in capillary plug seal grooves on both sides of enclosure wall. Inside retaining ring should be placed on seal plug before passing capillary bulb through enclosure opening provided. To prevent any possible shorting of terminals, route thermostat capillary close to lower enclosure wall. Refer to wiring diagram covering your model. For reassembly reverse the order to above procedure.

REPLACEMENT PARTS LIST NLA

ITEM	QTY	3, 5, 7.5 KW	10 KW	15, 20, 25 KW	DESCRIPTION
1	1	70667-001	70667-002	70667-003	CABINET WELDMENT
2	3	62022-001			LOUVER
2			62022-002		LOUVER
2				62022-003	LOUVER
3	4	62023-001	62023-002	62023-003	MOTOR SUPPORT
4	5	51634-001	51634-002	51634-003	BOTTOM COVER
5	1	70671-001	70671-002	70671-003	FAN GUARD
6	1	62003-001	62003-002	62003-003	FAN GUARD
7	1	51510-004	51510-005	51510-006	HIGH LIMIT CONTROL
8	1	52823-001	52823-002	52823-003	CONDUIT MOTOR 3/4
9	1	52823-001	52823-002	52823-004	CONDUIT JUNCTION BOX 3/4
10	1	PROVIDE MODEL NUMBER			

Heat Exchanger Complete with relief valve, elements, fluid charge, slip-joint and element enclosure cover.
--

COMMON TO ALL SIZES PARTS LIST		
ITEM	PART NUMBER	DESCRIPTION
11	58027-036	CONTACTOR, 50 AMP 3 POLE 24 VOLT COIL
11	58027-037	CONTACTOR, 50 AMP 3 POLE 120 VOLT COIL
11	58027-038	CONTACTOR, 50 AMP 3 POLE 208/240 VOLT COIL
12	51704-001	TRANSFORMER 208/240/480 VOLT PRIMARY 24 VOLT SECONDARY
12	51512-001	TRANSFORMER 208/240/480 VOLT PRIMARY 120 VOLT SECONDARY
12	51704-002	TRANSFORMER 600 VOLT PRIMARY 24 VOLT SECONDARY
13	51511-002	FUSE BLOCK 2 POLE
14	43810-003	FUSE 3.0 AMP TIME DELAY
14	43810-002	FUSE 4/10 AMP TIME DELAY
14	43810-001	FUSE 2/10 AMP TIME DELAY
15 (3.5, 7.5, 10KW)	62034-001	MOTOR, 1/4 HP 208/240/480 VOLT SINGLE PHASE
16 (3.5, 7.5, 10KW)	62034-002	MOTOR, 1/4 HP 208/240/480 VOLT SINGLE PHASE
17 (3.5, 7.5, 10KW)	62034-003	MOTOR, 1/4 HP 600 VOLT THREE PHASE
15 (15, 20, 25KW)	62034-004	MOTOR, 1/2 HP 208/240/480 VOLT THREE PHASE
16 (15, 20, 25KW)	62034-005	MOTOR, 1/2 HP 600 VOLT THREE PHASE
16	62024-001	ELEMENT ENCLOSURE COVER
17	62032-001	ELEMENT ENCLOSURE (EXPLOSION PROOF) THREADED COVER
18	41352-001	CAUTION PLATE
19	70672-003	CONTROL BOX EXPLOSION PROOF (PROVISIONS FOR THERMOSTAT OPTION)
20	62031-002	CONTROL BOX EXPLOSION PROOF COVER
21	51637-001	THERMOSTAT (STAINLESS STEEL CAPILLARY)
22	43633-001	THERMOSTAT RETAINING RING (2 REQUIRED)
23	41341-001	THERMOSTAT SHAFT ASSEMBLY
24	43758-001	3/4" CONDUIT UNION FEMALE (MOTOR)
25	43755-001	3/4" CONDUIT UNION MALE (JUNCTION BOX)
26	51638-001	3/4" SLIP-JOINT FITTING (JUNCTION BOX TO ELEMENT ENCLOSURE)
27	43672-001	DRIVE SCREW #6 X 3/16"
28	62034-000	MOTOR JUNCTION BOX (EXPLOSION PROOF)

TERMS AND WARRANTY

RETURNED MERCHANDISE

Goods may not be returned without the company's written permission. All transportation costs for returned goods must be paid by the customer:

FREIGHT DAMAGE CLAIMS

Title to goods shipped passes to the consignee upon delivery by the company to the carrier. All claims for shortages or damage must be made to the carrier by the consignee. In case of concealed damage it is important that such damage be reported to the delivering carrier within one week.

WARRANTY LIMITED WARRANTY TO OWNER TPI CORPORATION EFFECTIVE MAY 1, 1977

The warranty herein set forth is in lieu of all other warranties expressed or implied, and shall not apply to any accessory not part of the product.

TPI Corporation, hereafter referred to as the company of Johnson City, Tennessee 37602, warrants its products to the owner against defects in material and workmanship for a (12) month period under normal use and services following date of manufacture or installation when proof of such is provided to seller.

This warranty requires that the owner, or his agent install the equipment in accordance with the National Electrical Code, any other applicable heating or electrical codes and the manufacturer's installation instructions. It further requires that he perform reasonable and necessary maintenance on the unit. The company is not liable for abuse or misuse of product as may be finally determined by inspection by the company.

The obligation of the manufacturer, under the terms of this warranty, shall be to supply a new part, or the repair of defective part at the company's option with no costs to owner for the new or repaired part. Such parts are to be returned to the factory, or such other location as the company may designate at the owner's expense. This warranty does not obligate the manufacturer to bear the cost of labor in replacing any assembly, unit or component part thereof, nor does the company assume any liability for secondary charges, expenses for installing or removal, or any other consequential losses, freight or damages. The company's maximum liability shall not in any case exceed the list price for the product claimed to be defective.

IN CASE OF PRODUCT FAILURE

It shall be the obligation of the owner to furnish to the company within the designated warranty period, the following information:

1. Model number and date of manufacture of product involved.
2. Complete description of the problem encountered with product.

Upon receipt of the above, the company will reply to the owner within a period not to exceed fifteen (15) working days, the action to be taken by owner.

When requested, it shall be the obligation of the owner to return the defective part to the company within thirty (30) days after its removal, or otherwise to follow instructions from the company.

HAZARDOUS LOCATIONS DEFINITIONS

HAZARDOUS LOCATIONS - Areas where the possibility of explosion or fire exists because of the presence of flammable gases, vapors, or dust etc.

DIVISION 1 - Locations where the hazard is expected to be present during normal production operations, or during frequent maintenance and repair activities.

DIVISION II - Locations where the hazards would only exist as a result of an accident or other abnormal event such as a rupture or spillage.

CLASS I - Areas where sufficient quantities of flammable gases or vapors exist in the air to be explosive or ignitable.

- Offshore and land based drilling rigs, petroleum exploration and testing facilities.
- Petroleum refineries, gasoline storage and dispensing areas.
- Industrial firms that use flammable liquids in dip tanks for parts cleaning or other operations.
- Petrochemical companies that manufacture chemicals from gas and oil.
- Dry cleaning plants where vapors from cleaning fluids can be present.
- Aircraft hangars and fuel servicing areas.
- Utility gas plants and operations involving storage and handling of liquefied petroleum gas or natural gas.

GROUP D - Gases or vapors with specific explosive characteristics grouped together including:

Acetone	Cyclohexane	Iso Butyl Alcohol	Propane
Acrylonitrile	Decane	Isooctane	Propylene
Ammonia	Ethane	Isoprene	Propyl Acetate
Amyl Acetate	Ethylene Dichloride	Methane	Styrene
Amyl Alcohol	Ethyl Acetate	Methanol	Toluene
Benzene	Ethyl Alcohol	Methyl Acetate	Vinyl Acetate
Blast Furnace Gas	Ethyl Methyl Ketone	Methyl Alcohol	Vinyl Chloride
Buta - 1:3 Diene	Ethyl Nitrite	Naphtha	Xylene
Butane	Heptane	Natural Gas	
Butyl Acetate	Hexane	N-Butyl Alcohol	
Carbon Monoxide		Pentane	

CLASS II - Areas which are made hazardous by the existence of combustible dusts.

- Coal preparation plants and other carbon handling or processing areas
- Grain elevators, flour and feed mills.
- Plants that manufacture, use or store magnesium or aluminum powders.
- Plants that have chemical or metallurgical processes, producers of plastics, medicines and fireworks, etc.
- Producers of starch or candies.
- Spice grinding plants, sugar plants and cocoa plants.

GROUP E - Powdered metals such as aluminum and magnesium, and other metal dusts with similar characteristics.

GROUP F - Dusts such as carbon black, coke, and coal dust.

GROUP G - Dusts, including flour, starch, spices and grain dust.