

5100 SERIES

Select A Division:

HORIZONTAL/ VERTICAL UNIT HEATER

- Heavy 18 gauge steel construction
- Powder coated paint finish
- Copper clad steel sheath element with brazed fins and Nichrome element wire
- All units equipped with automatic over-heat limit protection
- Totally enclosed fan motors
- Louvers are individually adjustable for directional air flow
- Optional remote and unit mounted controls include thermostats, disconnects, and fan switches
- Optional accessories include mounting brackets, louvers, fan guards, and dust shields

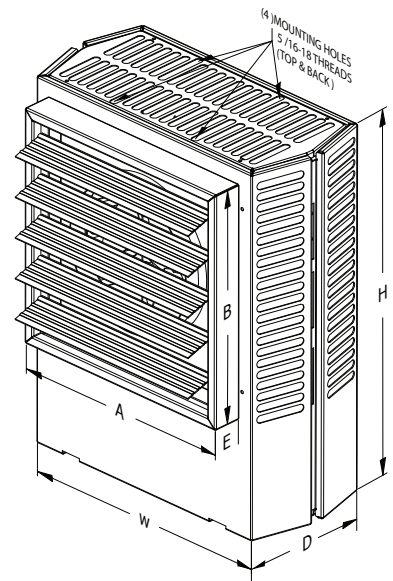

SUBMITTAL DATA SHEET

• Made in the U.S.A.

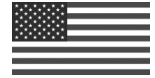

CUSTOMER						DATE		
PROJECT								
TAG								
QUANTITY								
MODEL								
KILOWATTS								
VOLTS								
PHASE								
DISCONNECT								
THERMOSTAT								
BRACKET								
OPTIONS								
OPTIONS								
UNIT SIZE KW	DIMENSIONS (Inches)						WEIGHT	
	H	W	D	E	A	B	(Pounds)	
3.3 & 5	17 3/4	14 15/32	6 1/2	1 5/8	11 1/2	11 1/2	25	
7.5 & 10	24 5/16	21 1/2	6 1/2	2 7/32	15 1/4	15 1/4	54	
15 & 20	28 11/16	21 1/2	6 1/2	2 7/32	15 1/4	15 1/4	65	
25 THRU 50	34	29 1/4	10 1/16	2 5/8	20 1/4	20 1/4	120	
60 & 70	35 1/2	30 1/2	14 1/2	5	23 1/2	23 1/2	141	
80 - 90 - 100	39 1/2	37 5/8	18 1/2	5	27 1/2	27 1/2	202	

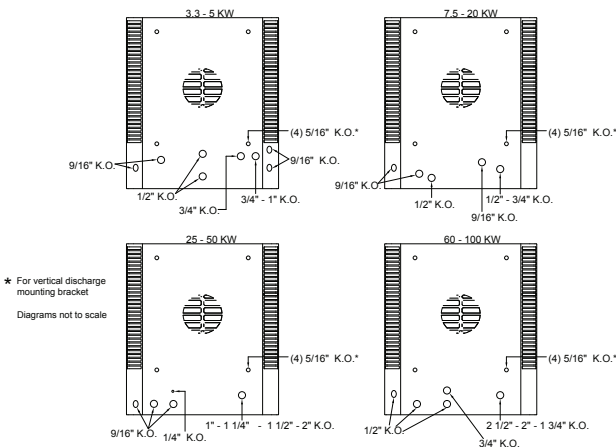

* For vertical discharge mounting bracket
Diagrams not to scale

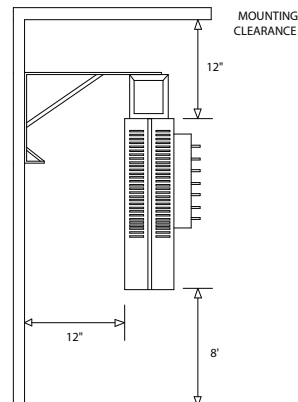

FIG. 1
HORIZONTAL DISCHARGE

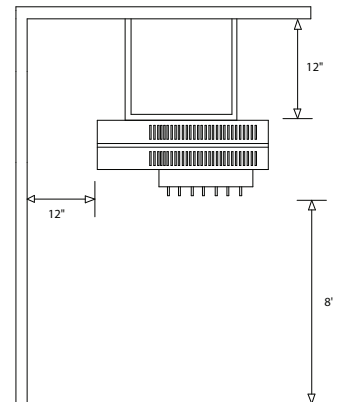
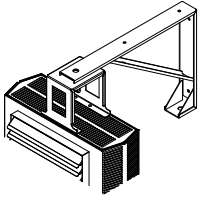
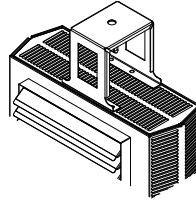

FIG. 2
VERTICAL DISCHARGE

5100 SERIES
ACCESSORIES
&
OPTIONS



A5100 BRACKET			
	HEATER KW	BRACKET	WEIGHT (lbs)
WALL BRACKET & HEATER BRACKET	3.3 - 5	A5105	9
	7.5 - 20	A5120	13
	25 - 50	A5150	16
	60 - 70	A5175	25
	80 - 100	A51100	36



B5100 BRACKET			
	HEATER KW	BRACKET	WEIGHT (lbs)
HEATER BRACKET	3.3 - 20	B5105	2
	25 - 50	B5150	3
	60 - 70	B5170	5
	80 - 100	B51100	12

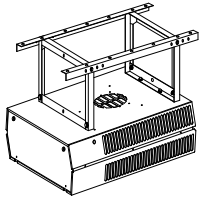

V5100 BRACKET			
	HEATER KW	BRACKET	WEIGHT (lbs)
VERTICAL MOUNT BRACKET	3.3 - 5	V5105	9
	7.5 - 20	V5120	13
	25 - 50	V5150	16
	60 - 70	V5175	19
	80 - 100	V51100	22

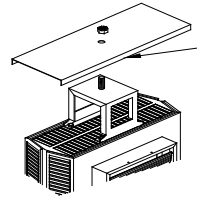

DS5100 DUST SHIELD			
	HEATER KW	SHEILD	WEIGHT (lbs)
DUST SHIELD	3.3 - 5	DS5105	3
	7.5 - 20	DS5120	4
	25 - 50	DS5150	5
	60 - 70	DS5175	10
	80 - 100	DS51100	17

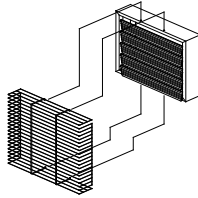

OFG5100 FAN GUARD			
	HEATER KW	GUARD	WEIGHT (lbs)
FAN GUARD	3.3 - 5	OFG5101	1
	7.5 - 20	OFG5102	1
	25 - 50	OFG5103	2
	60 - 70	OFG5175	4
	80 - 100	OFG51100	5

DISCONNECT SWITCH	DISCONNECT SWITCH MUST BE DERATED FOR USE AT MAX 80% OF TOTAL HEATER RATED AMPERAGE
-------------------	---

THERMOSTATS		(BUILT IN) FACTORY SUPPLIED AND FIELD INSTALLED (EXCEPT SD MODEL THERMOSTAR)
T5100	40°-100° F	SINGLE POLE SINGLE STAGE FIELD MOUNTED IN CONTROL SECTION KNOCKOUT PROVIDED
T5102	60°-120° F	DPST FIELD INSTALLED - USE WITH 3.3 AND 5 KW UNITS LINE VOLTAGE WITH THREE PHASE POWER
T5122	45°- 90°	LOW VOLTAGE TWO STAGE FIELD INSTALLED FOR USE WITH UNITS 25 TO 50 KW
RF120EAA	50°-90° F	WALL MOUNTED SINGLE STAGE LOW VOLTAGE
TW123	40°-90° F	WALL MOUNTED TWO STAGE LOW VOLTAGE (25 TO 50 KW UNITS)
ET9SS	50°-90° F	WALL MOUNTED LINE VOLTAGE SINGLE POLE 22 AMP 120-277 VOLT
TW1512	50°-90° F	DPST WALL MOUNTED LINE VOLTAGE 25 AMP 120-277 VOLT (3.3-5 KW ON 3 PHASE POWER)
SD	50° - 90° F	SETBACK CONTROL WITH OCCUPANCY SENSOR AND DIGITAL DISPLAY

STEP CONTROLLER	60 TO 100 KW UNITS ONLY
SEQUENCES ON THE STAGING IN THE 60 TO 100 KW HEATERS USING FIELD SUPPLIED SIGNAL OR C1025 WALL THERMOSTAT	
C1025 THERMOSTAT	WALL THERMOSTAT WITH 0-10 VDC PULSING SIGNAL FOR STEP CONTROLLER

FAN CONTROL		(BUILT IN) FACTORY INSTALLED OR FIELD INSTALLED
FS		SUMMER FAN SWITCH FACTORY INSTALLED IN HEATER
TFS		SUMMER FAN SWITCH REMOTE WALL MOUNTED
TC5102 OR TC5103		STRATIFICATION THERMOSTAT FACTORY INSTALLED IN HEATER
TC1602		STRATIFICATION THERMOSTAT REMOTE WALL MOUNTED

5100 SERIES BRACKETS

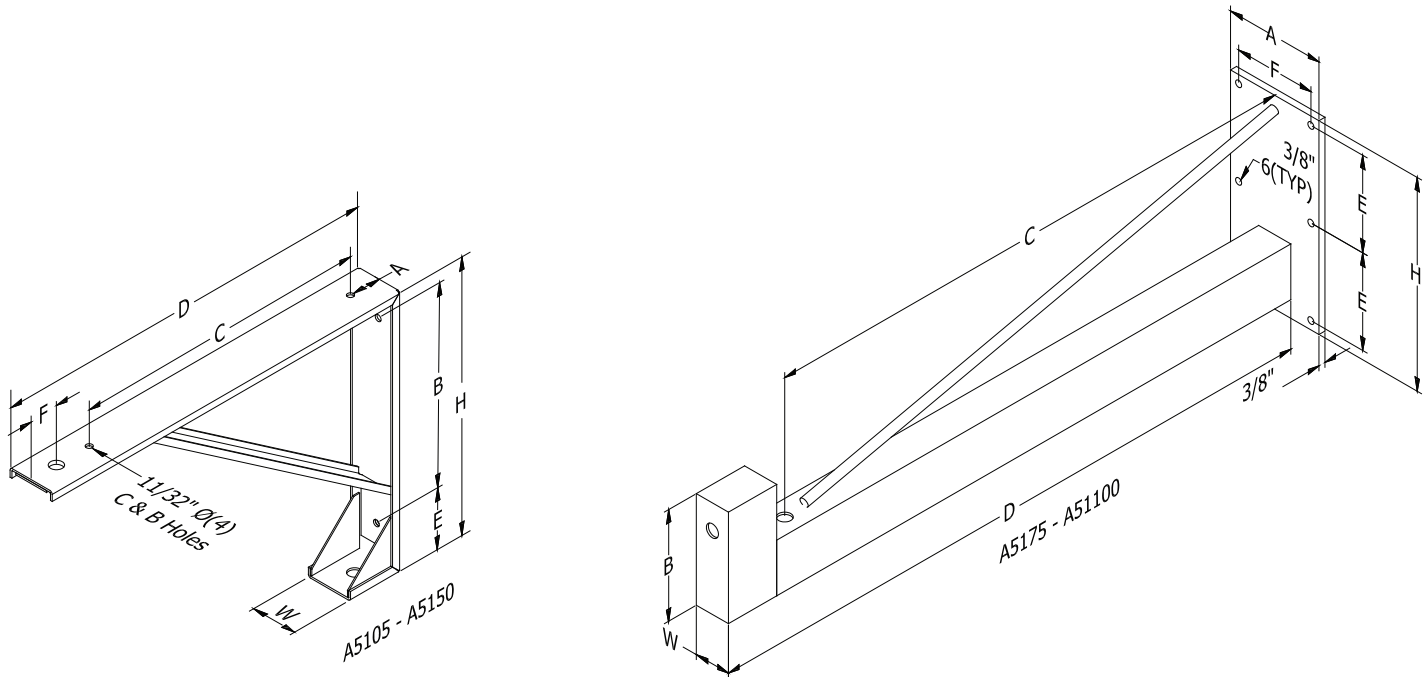

A5100 BRACKET

	HEATER KW	BRACKET	WEIGHT (lbs)	A	B	C	D	E	F	H	W
WALL BRACKET	3.3 - 5	A5105	9	1-3/4	10-1/2	9-1/4	20-3/4	2	1-1/2	14-1/2	2-1/2
	7.5 - 20	A5120	13	2-1/8	12	20-1/8	25-1/8	2-1/8	2-5/32	16	3-1/2
	25 - 50	A5150	16	2-1/8	13-1/2	19-7/8	28-3/4	2-1/8	2-1/8	17-1/2	3-1/2
	60 - 70	A5175	25	5-1/2	6-1/8	30-1/2	35	5-1/4	4-1/2	11-1/2	2
	80 - 100	A51100	36	5-1/2	6-1/8	30-1/2	35	5-1/4	4-1/2	11-1/2	2

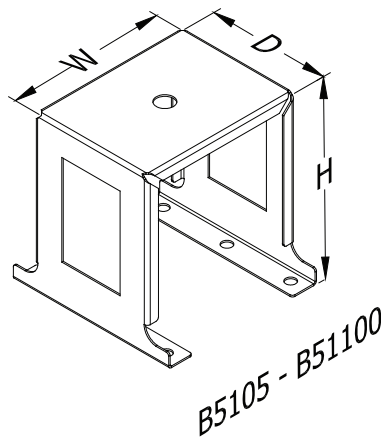

B5100 BRACKET

	HEATER KW	BRACKET	WEIGHT (lbs)	D	H	W
HEATER BRACKET	3.3 - 20	B5105	2	4-1/4	6	6-1/2
	25 - 50	B5150	3	4-1/4	6	10-1/8
	60 - 70	B5175	5	4-1/4	6	13-3/4
	80 - 100	B51100	12	10-1/4	6	18

B5100 Included with A5100 brackets