



Industrial Air Circulator Instructions

For All HV-1 Accessory Bracket



READ AND SAVE THESE IMPORTANT INSTRUCTIONS

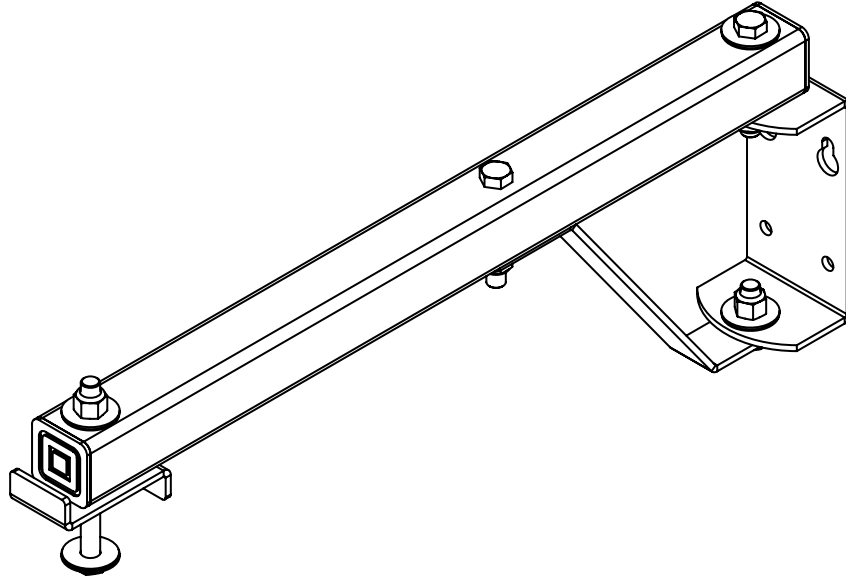

This TPI wall mount assembly is intended for use with TPI 18 inch High Velocity Fans: HV 18.

It is important that the following safety precautions be followed when using this product:

- Use only with TPI High Velocity Fans models beginning with HV18.
- DO NOT use with models beginning with HV24 or HV30.
- **WARNING:** To reduce the risk of fire, electrical shock, or injury to persons, observe the following: Use this unit only in the manner intended by the manufacturer. If you have questions, contact the manufacturer.
- Installation work and electrical wiring must be done by qualified person(s) in accordance with all applicable codes and standards, including fire-rated construction.
- When cutting into wall or ceiling, do not damage electrical wiring and other hidden utilities.
- **Avertissement:** Pour reduire les risques d'incendie ou de choc electrique, ou de blessures, respectez les consignes suivantes:
- Utiliser cette unite uniquement de la maniere prevue par le fabricant. Si vous avez des questions, contactez le fabricant.
- lorsque la moyenne de la deconnexion n'est pas bloquee, fixez solidement un avertissement bien en evidence, comme une etiquette sur le panneau de service. Les travaux d'installation et decablage electrique doivent etre effectues par des personnes qualifiees conformement a tous les codes et normes applicables, y compris la construction par incendie.
- Lorsque vous coupez dans le mur ou le plafond, n'endommagez pas le cablage electrique et d'autres utilitaires caches.

INSTALLATION INSTRUCTIONS

For installation on wood structures, use a 3/8" lag screw of appropriate length for the application.

For installation on steel structures, use a 3/8" bolt of the appropriate length for the application, in combination with a flat washer, a lock washer and a 3/8" nut.

For installation on masonry structures, use a 3/8" lag screw, in combination with a lag shield, of appropriate length for the application.

Use wall mount bracket as a template for locating the holes to be drilled on mounting surface. Use an appropriately sized drill bit and drill holes through mounting surface.

Attach wall mount bracket to mounting surface using hardware not provided. It is recommended that a minimum of grade 5 fasteners be used.

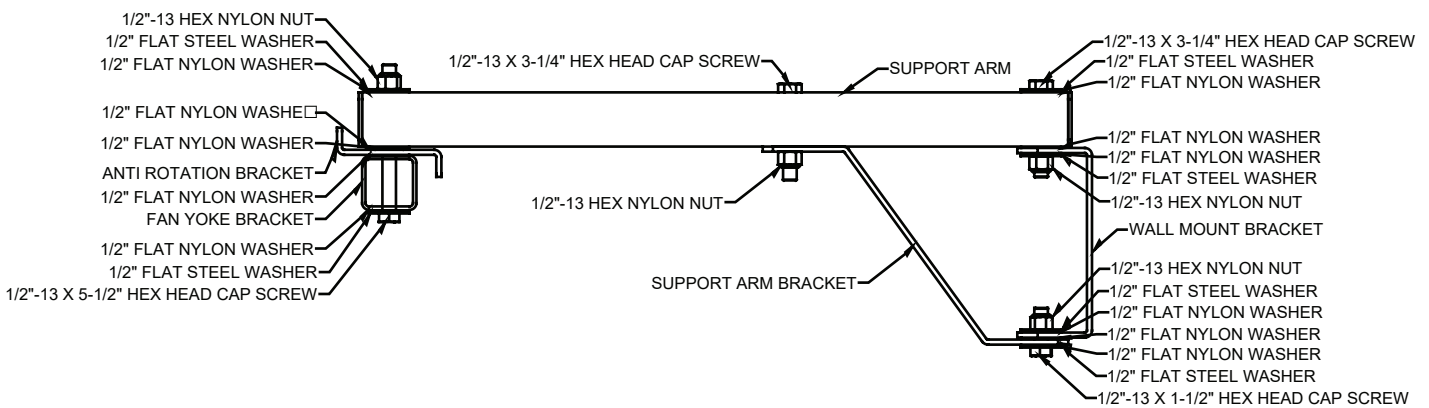

Assemble wall mount support arm and bracket as shown above with 1/2" bolts, steel washers, nylon washers, and nylon insert lock nuts. Securely tighten all fasteners. Support arm should be secure to wall bracket but still be capable of swiveling horizontally on the wall mount bracket.

Securely tighten all fasteners. Attach TPI HV18 Fan to wall mount assembly as shown above.

For additional information on TPI Products or replacement parts, call TPI Customer Service Department at 1-800-251-0382 or write the address below.

PO. Box 4973 • Johnson City, Tennessee 37602-4973 • 423-477-4131 • FAX 423-477-0683

HV-1

