

USER'S GUIDE

RWF SERIES WALL FAN HEATER

REPLACEMENT COMPONENT LIST INCLUDED

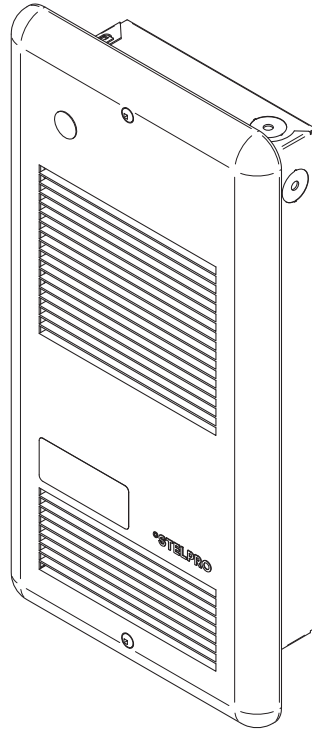

This unit
complies with
the CSA
standards



WARNING

Before installing and operating this product, the user and/or installer must read, understand and follow these instructions and keep them handy for future reference. If these instructions are not followed, the warranty will be considered null and void and the manufacturer deems no further responsibility for this product.

This product must be installed by a qualified person and connected by a **certified electrician**, according to the **electrical and building codes** effective in your region.

The following instructions must be adhered to in order to avoid personal injuries or property damages, serious injuries and potentially fatal electric shocks.

Protect the heating unit with the appropriate circuit breaker or fuse, in accordance with the nameplate.

Make sure the line voltage (volt) is consistent with that indicated on the unit's nameplate.

This unit must be **grounded**.

Switch off the power at the circuit breaker/fuse before installing, repairing and cleaning the unit.

Make sure the unit is appropriate for the intended use (if needed, refer to the product catalog or a representative).

RECOMMENDED HEATING CAPACITY:

1,25 W/cubic foot (0.03 m³).

It corresponds to **10 W/square foot (0.09 m²)** based on a standard ceiling height of 8 feet (2.44 m). The recommended capacity is usually sufficient for normal heating needs. Please note that the insulation quality of walls and windows are some of the factors that influence heat losses, which modify the required capacity to heat a room. If needed, refer to a specialist who will be able to calculate these heat losses and optimize the required capacity or consult the "Online heating calculation" section of the Stelpro Design Web site (residential buildings). To heat a large room and increase your comfort, it is recommended to install several units instead of one. For example, 2 X 1000 W rather than 1 X 2000 W.



WARNING

If the unit's capacity is insufficient for the size of the room, it will be in operation continuously, and may become defective earlier and turn yellow.

Do not install the unit where objects or pieces of furniture could be heat damaged.

Respect distances and positions indicated in the installation section.

If the installer or the user modifies the unit, he will be held responsible for any damage resulting from this modification, and the CSA certification could be void.

This unit must not come into contact with a water source and must be protected from splashes (e.g. a wet mop). Do not use it if any part has been immersed. Moreover, do not turn it on or off when standing in water or if your hands are wet.

When mounting the unit, make sure that the anchorage used can support the total weight of the unit with the mounting brackets.

When cutting or drilling into a wall, do not damage electrical wiring and other hidden utilities.

Do not install this product on walls made of synthetic material such as, but not limited to, carpet and wallpaper.

When starting up the unit for the first time or after a long period, it is normal that it produces some temporary odours and whitish smoke.

Because this unit is hot when in use, it may pose risks even in normal operation. Therefore, be careful and responsible when using it. To avoid burns, do not let bare skin touch hot surfaces. Let the unit cool down for a few minutes before handling it (it stays warm for some time after shut-down).

This unit must be installed at least 8 in (20.3 cm) from any adjacent surfaces (walls and floors). However, make sure flammable objects or pieces of furniture do not come into contact with the unit and keep them at least **12 inches (30.5 cm)** from it. Failure to comply with this warning could lead to a fire. Some materials are more heat-sensitive than others, so make sure those near the unit can withstand heat.

Do not install on a wall behind a door.

Never block unit air vents. This obstruction could lead to overheating, which could result in a fire.

Do not insert or allow foreign objects to enter any air vent as this may cause electric shocks, fires, or damages to the unit.

This unit has hot and arcing or sparking parts inside. It is not designed to be used or stored in wet areas or areas containing flammable liquids, combustible materials or corrosive, abrasive, chemical, explosive and flammable substances such as, but not limited to, gasoline, paint, chlorine, sawdust and cleaning products. Store it in a dry place.

Some areas are dustier than others. Thus, it is the user's responsibility to evaluate if the unit must be cleaned based on the amount of dirt accumulated on and inside air vents. Accumulated dirt can lead to a component malfunction or discoloration (yellowing). It may cause a fire if not installed and maintained in accordance with these instructions.

The thermal protection activation indicates that the unit has been subjected to abnormal operating conditions. If the thermal protection remains activated or activates and deactivates repeatedly, it is recommended that a qualified electrician or a certified repair centre examine the unit in order to make sure it is not damaged. (Refer to the limited warranty).

If the unit is damaged or defective, cut off power supply at circuit breaker/fuse and call a certified repair centre. (Refer to the limited warranty).

Make sure that all the electrical connections are secure and have been made properly. Pull each wire to ensure it is not loose in the connector or the terminal board as this may cause a fire.

If an option must be added, make sure it has been approved by Stelpro. This way, it will ensure that it has been tested in accordance with our safety rules and that an appropriate installation has been planned into the unit.

Note: When a part of the product specification must be changed to improve operability or other functions, priority is given to the product specification itself. In such instances, the instruction manual may not entirely match all the functions of the actual product. Therefore, the actual product and packaging, as well as the name and illustration, may differ from the manual.

SPECIFICATIONS

WALL FAN HEATER

MODEL	RWF
VOLTS	120, 208, 240/208, 277, 347 V
WATTS	500 TO 2000 W
WEIGHT	6 LB/2.7 KG
DEPTH	3 3/16"/80 MM
WIDTH	8 11/16"/220 MM
HEIGHT	17 1/8"/435 MM

TECHNICAL DRAWINGS

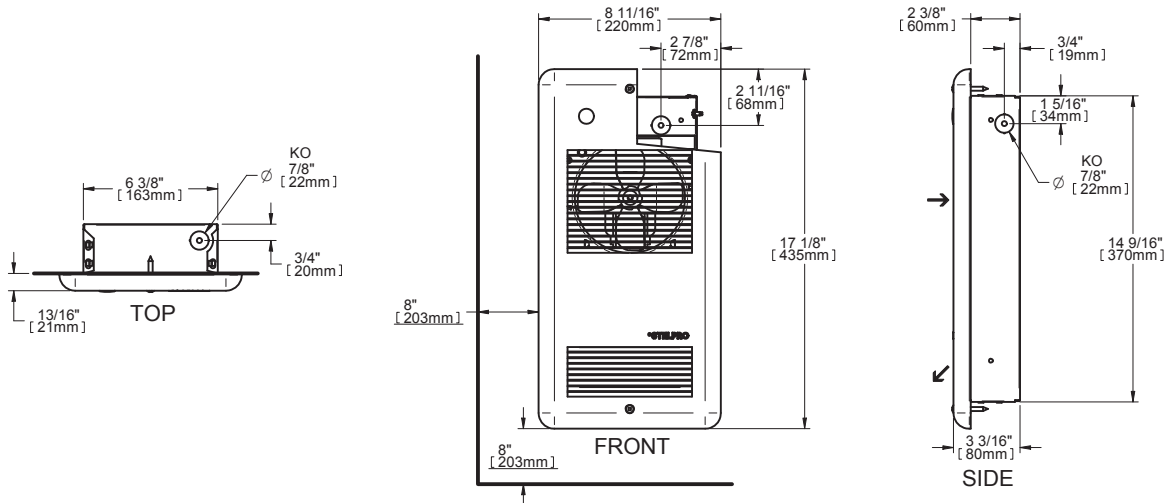

INSTALLATION

N.B. Cut off power supply at circuit breaker/fuse before proceeding to installation.

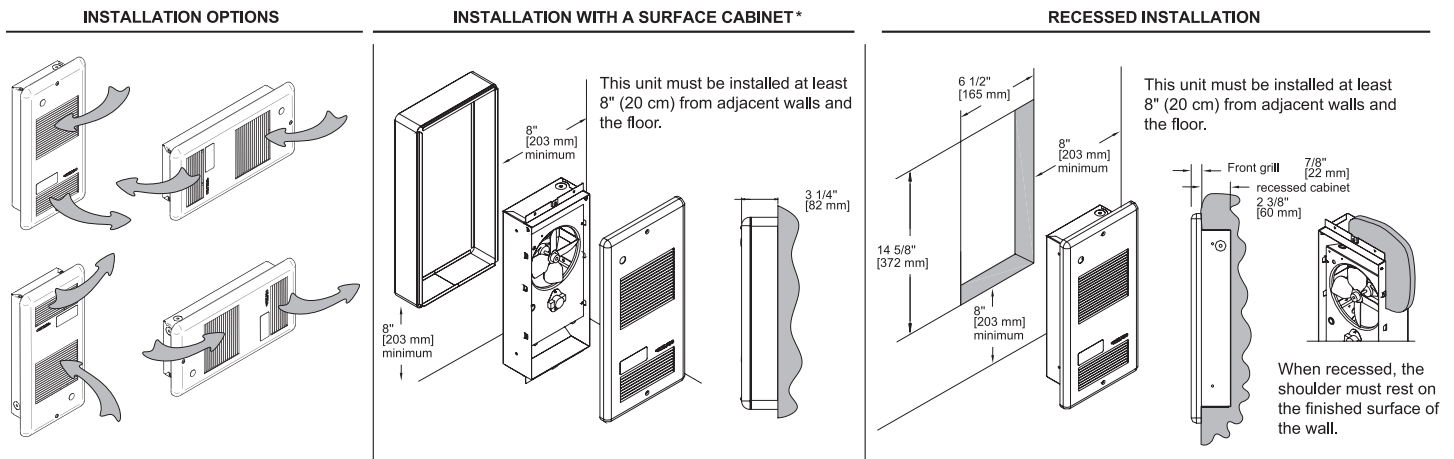

INSTALLATION OF THE BACK BOX IN A NEW BUILDING

WARNING: This unit must be installed at least 8" (20 cm) from adjacent walls and the floor.

1. Determine which side of the back box is to be mounted against a stud or ceiling joist. Allow for the thickness of the finished wall when installing the back box. The edge (shoulder) of the back box must be installed flush with the finished wall.
2. Disassemble the fan deck from the back box by removing 4 screws.
3. Position the back box on the appropriate stud or joist location and secure it using two nails or screws.
4. Remove one knockout in the back box to allow for the entry of the power supply cable.
5. Bring the power supply cable to the back box. Install a cable clamp and route the cable into the back box, leaving at least 6" (152mm) of cable inside the back box for connection to the unit's lead wires.
6. Put back the fan deck (4 screws).

* To facilitate installation with a surface cabinet, secure the heater to the wall, then place the cabinet and the grill together. Place the top screw in line with the mounting hole. Lastly, install the second screw.

MAINTENANCE

N.B. In order for the warranty to be valid, the unit must be cleaned regularly.

Cut off power supply at circuit breaker/fuse before cleaning the unit. Use a soft rag for dusting. When cleaning, use only a damp rag and non-abrasive dish soap. If you use a cleaning product, always wipe the product off properly to avoid the discoloration of the unit. Do not use abrasive or chemical cleaners because they can damage the finishing. If the unit is used in a very dusty location, use a vacuum brush to remove dust and other foreign objects from the grilles. Note that cigarette smoke could yellow the discharge grille and that the best way to prevent this problem is to clean the unit regularly.

Do not use cleaning products identified with these symbols:



N.B. Note that there is electrical current to the unit even if the thermostat is off. Meaning that there is a risk of electric shock as long as the unit is energized.

TROUBLESHOOTING

PROBLEM	DEFECTIVE PART OR PART TO CHECK
The unit does not work	<ul style="list-style-type: none"> • Defective thermostat or wrong thermostat setting • Open circuit breaker or fuse • Activated thermal protection • Faulty connections
The unit runs continuously	<ul style="list-style-type: none"> • Defective thermostat or wrong thermostat setting • Heat losses greater than the unit's capacity
The enclosure is extremely hot	<ul style="list-style-type: none"> • Defective thermal protection • Blocked air vents • Defective motor
The unit cycles under control of the thermal protection (overheat indicator)	<ul style="list-style-type: none"> • Blocked air vents • Defective motor
Overheating	<ul style="list-style-type: none"> • Defective thermostat or wrong thermostat setting • Defective motor
The breaker trips when the heater is turned on	<ul style="list-style-type: none"> • Faulty connections • Voltage higher than indicated on the nameplate
Elements are on, but the motor does not work	<ul style="list-style-type: none"> • Defective motor
The desired room temperature cannot be reached	<ul style="list-style-type: none"> • One or more defective elements • Defective thermostat or wrong thermostat setting • Voltage lower than indicated on the nameplate • Heat losses greater than the unit's capacity

N.B. If you do not solve the problem after checking these points, cut off the power supply at the main electrical panel and contact our customer service (see the "Limited warranty" section to obtain the phone numbers).

REPLACEMENT COMPONENT LIST

REF. #	PART #	DESCRIPTION
1	BOUT-009	WHITE THERMOSTAT BUTTON
1	BOUT-010	BLACK THERMOSTAT BUTTON
1	BOUT-011	ALMOND THERMOSTAT BUTTON
2	SB-005	WHITE PLUG 5/8"
3	ELF-RWF001	ELEMENT (KIT) 500W-120V/1500W-208V/2000W-240V
3	ELF-RWF002	ELEMENT (KIT) 0750 W-240 V
3	ELF-RWF003	ELEMENT (KIT) 0500 W-240 V
3	ELF-RWF004	ELEMENT (KIT) 1000 W-120 V
3	ELF-RWF005	ELEMENT (KIT) 500/1000 W-240 V
3	ELF-RWF006	ELEMENT (KIT) 1250 W-240 V
3	ELF-RWF007	ELEMENT (KIT) 1000 W-240 V
3	ELF-RWF007	ELEMENT (KIT) 750 W-208 V
3	ELF-RWF008	ELEMENT (KIT) 1500 W-240 V
3	ELF-RWF009	ELEMENT (KIT) 1500 W-120 V
3	ELF-RWF010	ELEMENT (KIT) 2000 W-208 V
3	ELF-RWF014	ELEMENT (KIT) 500 W-347 V
3	ELF-RWF015	ELEMENT (KIT) 750 W-347 V
3	ELF-RWF016	ELEMENT (KIT) 1000 W-347 V
3	ELF-RWF017	ELEMENT (KIT) 1250 W-347 V
3	ELF-RWF018	ELEMENT (KIT) 1500 W-347 V
3	ELF-RWF019	ELEMENT (KIT) 2000 W-347 V
3	ELF-RWF020	ELEMENT (KIT) 750/1500 W-240 V
3	ELF-RWF021	ELEMENT (KIT) 1000/2000 W-240 V
3	ELF-RWF022	ELEMENT (KIT) 500 W-277 V
3	ELF-RWF023	ELEMENT (KIT) 750 W-277 V
3	ELF-RWF024	ELEMENT (KIT) 1000 W-277 V
3	ELF-RWF025	ELEMENT (KIT) 1250 W-277 V
3	ELF-RWF026	ELEMENT (KIT) 1500 W-277 V
3	ELF-RWF027	ELEMENT (KIT) 2000 W-277 V
3	ELF-RWF028	ELEMENT (KIT) 500/1000 W-120 V
3	ELF-RWF029	ELEMENT (KIT) 750/1500 W-120 V
3	ELF-RWF030	ELEMENT (KIT) 500/1000 W-208 V
3	ELF-RWF031	ELEMENT (KIT) 750/1500 W-208 V
3	ELF-RWF032	ELEMENT (KIT) 1000/2000 W-208 V
3	ELF-RWF033	ELEMENT (KIT) 1250 W-120 V
3	ELF-RWF034	ELEMENT (KIT) 750 W-120 V

REF. #	PART #	DESCRIPTION
3	ELF-RWF035	ELEMENT (KIT) 1000 W-208 V
3	ELF-RWF036	ELEMENT (KIT) 500 W-208 V
3	ELF-RWF037	ELEMENT (KIT) 1250 W-208 V
4	M-RWF13Z*	GRILL
5	BLA-001	BLADE 5" 27" 4B
6	MO-001	MOTOR 1250-2000 W (208/240 V)
6	MO-002	MOTOR 500-1000 W-240 V
6	MO-010	MOTOR 500-1000 W 120 V
6	MO-011	MOTOR 1250-2000 W 208 V
6	MO-012	MOTOR 1250-2000 W-120 V
7	PROT-006	THERMAL PROTECTION (L-150) 500 TO 1250W
7	PROT-005	THERMAL PROTECTION (L-175) 1500 TO 2000W
8	ST-017	THERMOSTAT SP (240 V MAX)
8	ST-013	THERMOSTAT DP (600 V MAX)
9	M-RWF00A0	ADAPTER

* Add W for white and SW for silica white

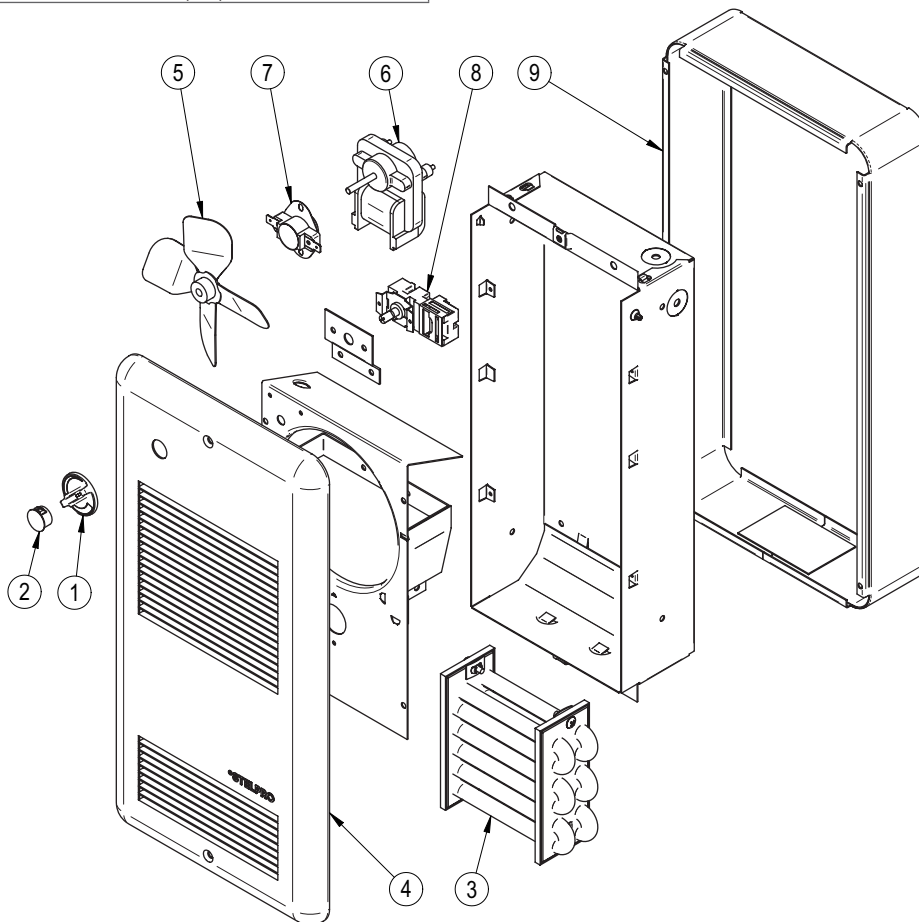

LIMITED WARRANTY

This limited warranty is offered by Stelpro Design Inc. ("Stelpro") and applies to the following product made by Stelpro: model RWF. **Please read this limited warranty carefully. Subject to the terms of this warranty**, Stelpro warrants its products and their components against defects in workmanship and/or materials for the following periods from the date of purchase: **5 years**. This warranty applies only to the original purchaser; it is non-transferable and cannot be extended.

Claim procedure

If at any time during the warranty period the unit becomes defective, you must cut off the power supply at the main electrical panel and contact 1) your installer or distributor, 2) your service center or 3) Stelpro's customer service department. In all cases, you must have a **copy of the invoice** and provide the **information written on the product nameplate**. Stelpro reserves the right to examine or to ask one of its representatives to examine the product itself or any part of it before honoring the warranty. Stelpro reserves the right to replace the entire unit, refund its purchase price or repair a defective part. Please note that repairs made within the warranty period must be authorized in advance in writing by Stelpro and carried out by persons authorized by Stelpro.

Before returning a product to Stelpro, you must have a Stelpro authorization number (RMA). To obtain it, call the customer service department at: **1-800-363-3414** (electricians and distributors - French), **1-800-343-1022** (electricians and distributors - English), or **1-866-766-6020** (consumers). The authorization number must be clearly written on the parcel or it will be refused.

Conditions, exclusions and disclaimer of liability

This warranty is exclusive and in lieu of all other representations and warranties (except of title), expressed or implied, and Stelpro expressly disclaims and excludes any implied warranty of merchantability or implied warranty of fitness for a particular purpose.

Stelpro's liability with respect to products is limited as provided above. Stelpro shall not be subject to any other obligations or liabilities whatsoever, whether based on contract, tort or other theories of law, with respect to goods or services furnished by it, or any undertakings, acts or omissions relating thereto. Without limiting the generality of the foregoing, Stelpro expressly disclaims any liability for property or personal injury damages, penalties, special or punitive damages, damages for lost profits, loss of use of equipment, cost of capital, cost of substitute products, facilities or services, shutdowns, slowdowns, or for other types of economic loss or for claims of a dealer's customers or any third party for such damages. Stelpro specifically disclaims all consequential, incidental and contingent damages whatsoever.

This warranty does not cover any damages or failures resulting from: 1) a faulty installation or improper storage; 2) an abusive or abnormal use, lack of maintenance, improper maintenance (other than that prescribed by Stelpro) or a use other than that for which the unit was designed; 3) a natural disaster or an event out of Stelpro's control, including, but not limited to, hurricanes, tornadoes, earthquakes, terrorist attacks, wars, overvoltage, flooding, water damages, etc. This warranty does not cover any accidental or intentional losses or damages, nor does it cover damages caused by negligence of the user or owner of the product. Moreover, it does not cover the cost of disconnection, transport, and installation.

The warranty is limited to the repair or the replacement of the unit or the refund of its purchase price, **at the discretion of Stelpro**. Any parts replaced or repaired within the warranty period with the written authorization of Stelpro will be warranted for the remainder of the original warranty period. This warranty will be considered null and void and Stelpro will have the right to refuse any claims if **products have been altered** without the written authorization of Stelpro and if the nameplate numbers have been removed or modified. This warranty does not cover scratches, dents, corrosion or discoloration caused by excessive heat, chemical cleaning products and abrasive agents. It does not cover any damage that occurred during the shipping.

Some states and provinces do not allow the exclusion or limitation of incidental or consequential damages and some of them do not allow limitations on how long an implied warranty lasts, so these exclusions or limitations may not apply to you. This warranty gives you specific legal rights and you may have other rights which vary from state to state or from province to province.