

Solaira^o™

SOLAIRA COSY AW

Reference Manual

for Europe: Rio 2IP (RIO 215IP/220 CUS)

1.5kW,120v/1.5kW,240V/2.0kW,240V

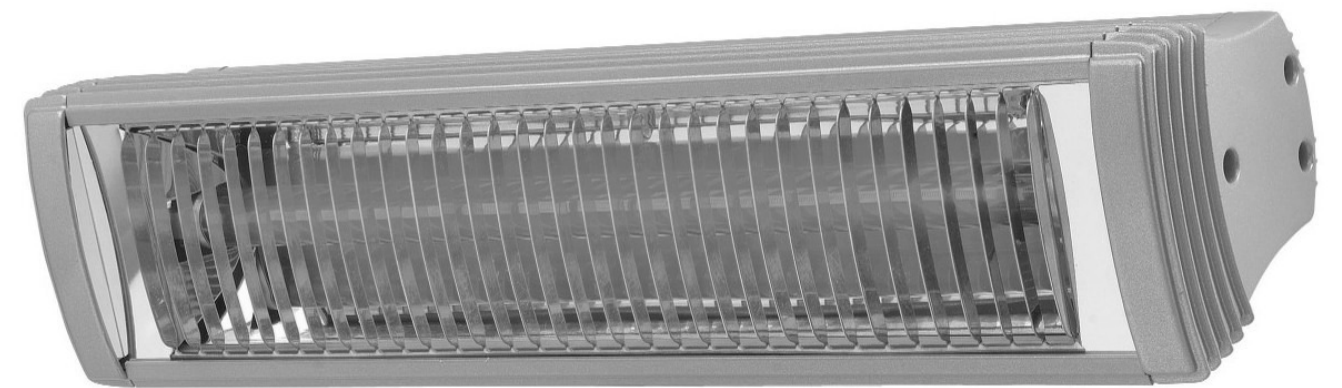

**INFORESIGHT
CONSUMER PRODUCTS INC.**

125 Traders Blvd. E Unit # 4, Mississauga, Ontario L4Z 2H3

Tel: 905-568-7655 Fax: 905-568-7521

Email: info@solairaheaters.com Website: www.solairaheaters.com

Introduction

The Rio heater produces radiant heat like the sun, warming people and objects rather than the air in between. It is mounted on an adjustable bracket that allows the heat to be directed exactly where it is required. Its attractive, lightweight design means that it is effective yet unobtrusive. The Rio is designed for indoor and outdoor use so is therefore weatherproof.

Please read the following instructions carefully before use. The safety of this heater is guaranteed only by its correct usage in accordance with these instructions, therefore it is recommended that they are retained for future reference.

Caution

Before using this appliance:

- Check that the voltage indicated on the type plate corresponds to the mains supply voltage.
- Do not locate the heater immediately below a socket outlet.
- Ensure that the heater has been securely fastened in its final mounting position.
- Remove the plug from the mains socket (or disconnect pole switch) during installation, cleaning and/or replacing the emitter and always ensure that the emitter is cool.
- Do not handle the halogen emitter with bare hands. If it is inadvertently touched, remove finger marks with a soft cloth and methylated spirit or alcohol. Otherwise, the marks will burn into the quartz emitter causing premature heater failure.
- Do not use an extension cable with this product.
- Keep the mains cable away from the body of the heater which will get hot during use.
- Do not cover or obstruct the heater while it is in use.
- The heater is not intended for use by young children or infirm persons unless they have been adequately supervised by a responsible person to ensure that they can use the heater safely.
- Do not insert any object through any slot or opening in the heater.
- Do not use if guard is not present.
- Do not install less than the minimum mounting distance from the floor.
- **Warning - this appliance must be earthed!**

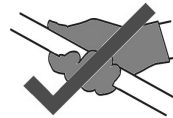

Risk of Fire

Keep combustible materials such as furniture, papers, clothes and curtains at least 6 feet (1.8m) from the front of the heater and away from the sides and rear. If the lamp is to be used outside, we recommend that a waterproof or indoor socket is used.

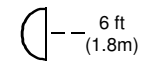

Specification

Table 1. Canada and USA Heaters

Model	Voltage (V)	Total Power (W)	Current (A)	Min height from floor (m)	Min distance from ceiling (inches)	Min distance from side wall (inches)	Dimensions WxHxD (inches)	Weight (lbs)	Ingress Protection (IP)
Rio 215IP	120	1500	12.5	6' 7"	11 3/4	59	15 1/2 x 4 x 6	5.2	IPX4
Rio 215IP	240	1500	6.4	6' 7"	11 3/4	59	15 1/2 x 4 x 6	5.2	IPX4
Rio 220IP	240	2000	8.7	6' 7"	11 3/4	59	15 1/2 x 4 x 6	5.2	IPX4

Use MCB Type 3 or equivalent.

Your Replacement Lamp

It is very important that your replacement lamp is exactly the same as the one it was supplied with. Failure to fit the exact same type could cause the heater to fail or even become dangerous especially when used in an outdoor environment. Please contact the retailer or seller to purchase your replacement lamp and state the model number of the heater you wish to fit the lamp to in the first instance.

Handling the Replacement Lamp

Your new lamp should not be handled with bare hands. Remove finger marks with a soft cloth and methylated spirits or alcohol. Finger marks will burn into quartz causing premature lamp failure. Also note the heater outer casing can reach high temperatures.



Disposal of product:

By ensuring this product is disposed of correctly, you will help prevent potential negative consequences for the environment and human health, which could otherwise be caused by inappropriate waste handling of this product.



17. From inside of the heater body, push one of the leads through the black rubber gasket and into the terminal box. The gasket has two small holes in it and one wire per hole should be inserted (the sleeving needs to be pulled back so only the white wire comes through) and push it firmly into either one of the terminals. Hold in place and tighten the screw fully (see Fig. 17).

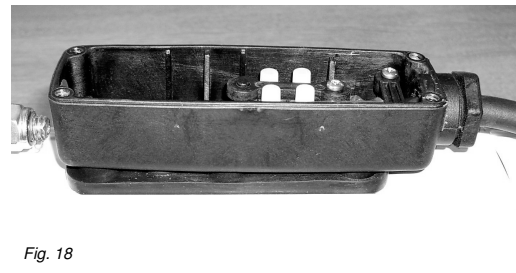

18. Push the other lamp lead through the second hole in the gasket and fit to the second terminal of the connector block (Fig. 17). The connector block can now be returned to its locating lugs and the screws checked for tightness. Replace the saddle and screw (Fig. 18).

19. The back plate can now be placed on the back of the heater and the locating lugs pushed in as shown in Fig. 19.



Fig. 19

20. The other end casing can be aligned and ensuring the lead is not going to get trapped (as step 15!) and is positioned as shown in Fig 20, push the end casing into place. It is recommended that the heater is stood up on its fixed end and downward force applied to ensure everything goes back together correctly (Fig. 21).

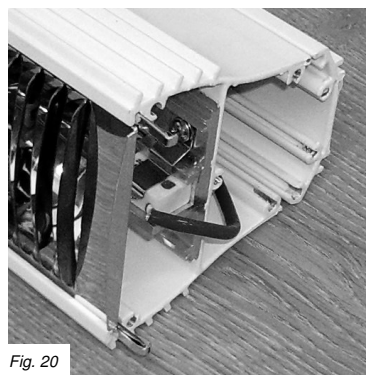

Fig. 20

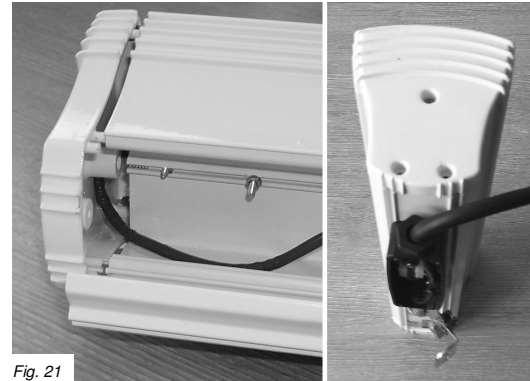

Fig. 21

21. If the leads are free to move and the guard and side reflectors are in order, the back plate should be closed and all screws refitted and checked for tightness as Fig. 22.

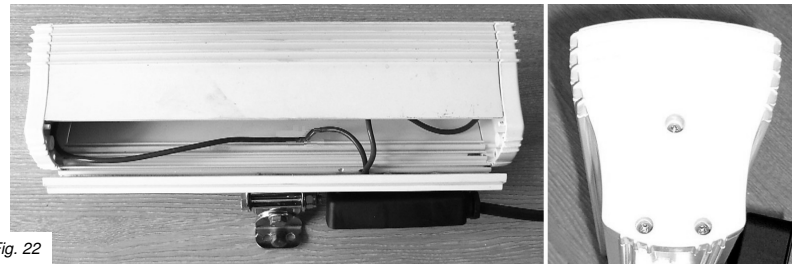

Fig. 22

22. Make a final check in the terminal box that all of the wires are secure and replace the cover and refit the screws.

23. The heater can now be returned to its original mounting position and the mains power reconnected.



Fig. 23

Installation

The Rio heater is fitted with 16'5" (5m) of supply cable and a moulded plug, therefore it is unnecessary to open the terminal box in order to carry out normal installation of this product and should not be interfered with.

- We recommend using a RCD where applicable.
- Please observe the minimum safe distance between the heater body and any inflammable surfaces.
- If the supply cord becomes damaged, it must be replaced by the manufacturer, its service agent or a similar qualified person in order to avoid a hazard.
- When the electrical connection is outside, it is recommended that a waterproof socket is used for the connection. Otherwise, the plug should be connected to a socket indoors.
- If in any doubt, please contact a suitably qualified electrician.

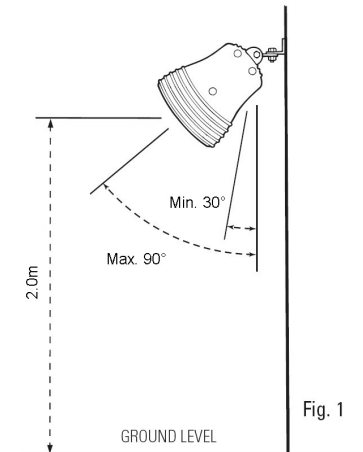

Fig. 1

Mounting

- The Rio models RIO 215IP and RIO 220IP can be mounted in a horizontal or vertical manner hence the term universal burning.
- When mounting the Rio horizontally, do not position the heater at an angle more than 90° and less than 30° as shown in Fig. 1.
- When vertically mounting the Rio models, ensure to leave a gap between the heater and mounting surface (See Fig. 4 - dim A). The heater should always be angled downwards when mounting this way with the terminal box at the bottom of the heater - see Fig. 4. Do not position the heater at an angle more than 45° and less than 30° to the horizontal as shown.
- Always allow the heater to cool before attempting to reposition/move. Never attempt to move the heater while it is switched on!
- Observe the minimum safe distance between the heater body and inflammable surfaces and objects when mounting.
- Please refer to Table 1 for the recommended positioning of the heater.
- Keep out of the reach of children.

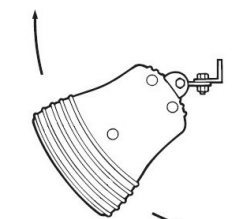

Fig. 2

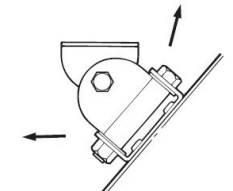

Fig. 3

1. Securely fasten the Rio bracket to the mounting surface using the fixing holes in the bracket. Please refer to Table 1 or 2 for recommended positioning of the heater.
2. Fix in the required angular position by tightening the fixing bolt on the bracket at the rear of the heater.
3. The Rio bracket can be used to adjust the direction of the heater up and down (see Fig. 2) and side to side (see Fig. 3). This is done by loosening the bolts fixing the heater to the bracket, and then retightening once the correct position is achieved.

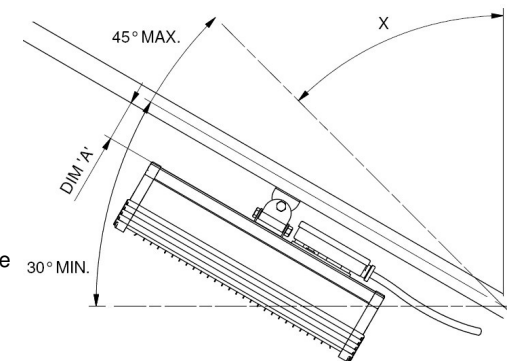

Fig. 4

Always isolate the heater from the mains supply when adjusting the angular position.

Maintenance

In the event of heater failure, or for spare parts or advice, please contact the manufacturer in the first instance.

- Disconnect from the mains before commencing any maintenance procedure including cleaning.
- To ensure optimum heat effectiveness, it is recommended that the guard and lamp are removed and the reflector is wiped with a lint-free cloth before reassembling should the reflector show signs of dust or dirt.

Replacing the Lamp

If you are in any doubt about following the procedure below, please contact us for technical assistance. The mains power should be disconnected before any attempts are made to replace the lamp. The following should be carried out with compliance to IEE regulations. Please read the notes on page 7 with regards to handling and buying a replacement lamp before proceeding.

1. Ensure the heater and lamp are cool and the power supply is disconnected by removing the plug from the socket outlet.
2. Remove the heater from its mounting and work on a safe, flat surface.
3. Remove the screws from the terminal box and lift off the lid.



Fig. 1

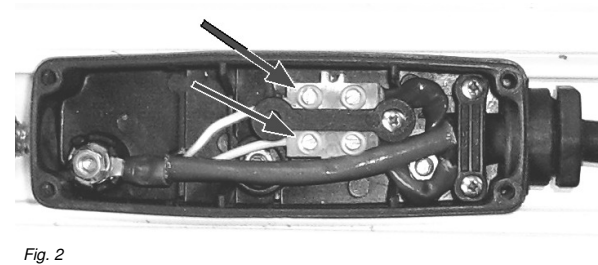

Fig. 2

4. Disconnect the lamp from the connector blocks by unscrewing the screws highlighted above in Fig. 2.
5. Unscrew the two self-tapping screws (see Fig. 3) from each side of the casing and let the back pivot down (Fig. 4).

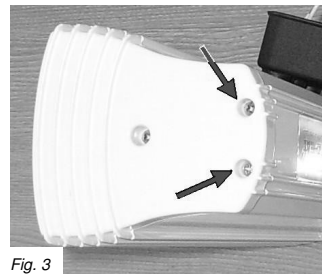

Fig. 3



Fig. 4

6. Gently pull the lamp wires through the back plate of the heater so the wires exit the terminal box (Fig 5).
7. Starting at the left hand side, remove the end casing - this may require a few gentle taps to disengage the locating lugs and allow the casing to become free. The back plate will also now be free from its fixings (Fig 6).
8. Slide out the side reflector and the guard completely through the open end to fully expose the lamp holder (Fig 7).

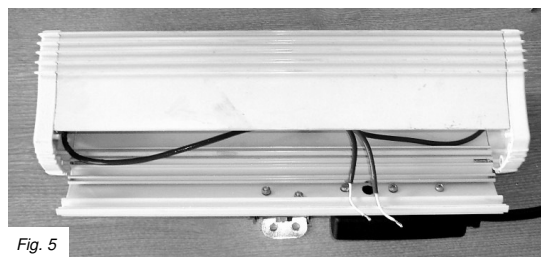

Fig. 5



Fig. 6

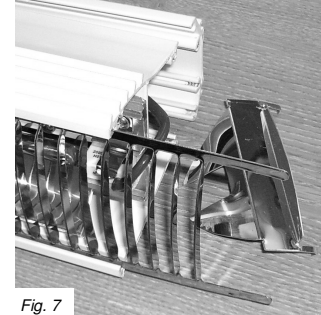

Fig. 7

9. Repeat the removal of the end casing on the opposite end and remove the other side reflector.

10. Release the lamp end by pressing the top edge of the spring clip away from the lamp on the lamp holder. Gently lift the end of the lamp upwards so it is no longer being retained by the clip (Fig. 8). Repeat at opposite end to fully remove the lamp.
10. Repeat the removal of the end casing on the opposite end and remove the side reflector. The lamp can be released from this side now and completely removed (Fig. 9). The heater should now be broken down in its part form as shown in Fig. 10.

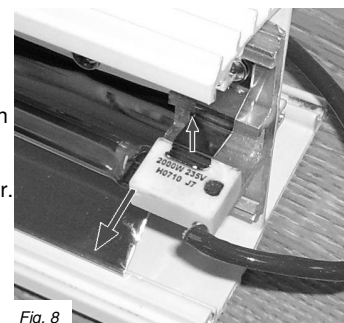

Fig. 8

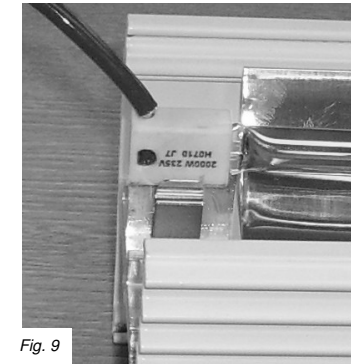

Fig. 9

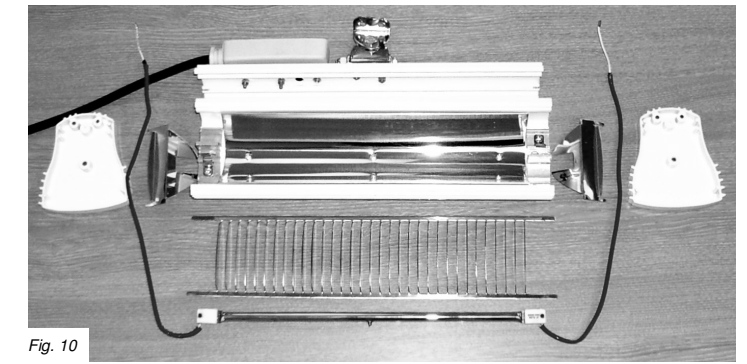

Fig. 10

11. Take your new lamp and refit by ensuring the leads pass down the sides of the lamp holders. The lamp can be clipped in by pulling the tabs back (Fig. 11). Please read the note about handling the lamp on page 7 before continuing.

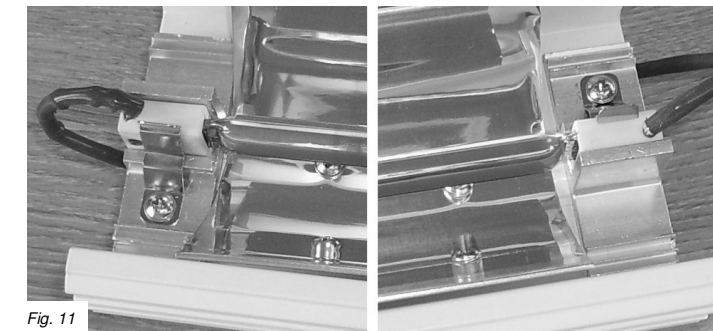

Fig. 11

12. The guard and side reflectors can now be refitted. Starting with the guard, slide it down its track and roughly centralise it. Then slide the side reflectors in at each end (Fig. 12).

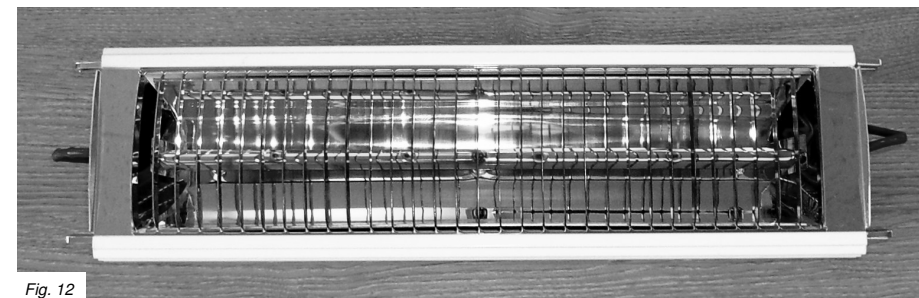

Fig. 12

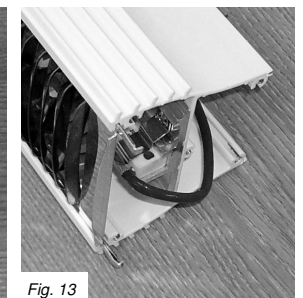

Fig. 13

13. Turn the heater over and starting with one end of the heater, place one of the lamp leads into the back of the heater and shape it so it is clear of the screw hole for the end casing (Fig. 13).

14. Take an end casing and refit by lining up the locating lugs - taking care that the lamp lead is free of the centre screw hole and rear mating surface. More pressure can be applied to the two parts to engage the lugs enough to see that the lead is not going to get trapped. This is extremely important! Should you trap a lead the heatproof sleeve should be removed and the insulation inspected for damage.

Any signs of damage will render the lamp unsuitable for use and should be replaced!

15. If the lamp lead is free, the end casing can be fully fitted by tapping into place firstly at the front then at the back (Fig. 15). The middle screw should be refitted.



Fig. 14



Fig. 15

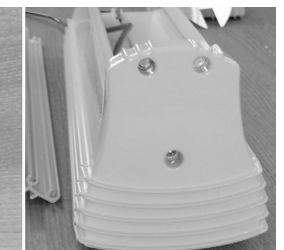

Fig. 16

16. At this point, the new lamp can be connected. Firstly remove the connector block saddle by removing the screw and lifting out. The connector block can be lifted out of its locating lugs to allow for better access when connecting the new lamp (see Fig. 16).