

# FROSTEX 9800 FlexFit Plug Kit

## FROSTEX PLUS PIPE HEATING SYSTEM USING THE 9800 FLEXFIT PLUG KIT INSTALLATION INSTRUCTIONS



### GENERAL INSTRUCTIONS

- Follow the installation steps (pages 2–6) in the exact order given.
- To ensure the plug is properly connected, do not assemble at temperatures below 0°F (-18°C).
- The Frostex Plus system can be left plugged in all year, but you will save energy by unplugging the system when the weather is not freezing.
- Use a properly grounded, 3-prong, 120-volt outlet. If you are not sure if your outlet is properly grounded, call a professional service person.
- In manufactured housing installations, use the electrical receptacle on the underside of the home. Do not use an extension cord or there may be danger of fire or shock. Also, use of an extension cord will void the UL Listing.
- Frostex Plus cable may be used on metal or plastic pipes and tubing. Do not install on garden hoses or in applications with tubing that is flexed repeatedly.
- Exposure to temperatures above 150°F (65°C) will shorten the life of your Frostex Plus cable. Before installing the cable on hot water pipes, set the water heater thermostat below 150°F (65°C) which is low to medium on most thermostats.
- Remove any old heating tapes and insulation before you install the Frostex Plus cable.
- Do not use more than 50 feet (15 meters) of Frostex Plus cable with each 9800 FlexFit plug. Longer lengths will blow the nonreplaceable fuse in the plug.
- The homeowner will need to keep these instructions for future reference.
- If you have any difficulty installing the system, please contact Pentair Thermal Management for information at (800) 545-6258, or call a professional service person for help.
- Remove the clear label that covers the test and reset buttons after installation.

### APPROVALS



60J9 Mobile Home  
Pipe Heating Cable

### KIT CONTENTS

Make sure your 9800 FlexFit Plug Kit is complete. It should contain:

Item	Qty	Description
1	Plug	
1	Push-on end seal	
2	Orange warning labels in English	
2	Orange warning labels in French	
1	White tape strip	

### TOOLS REQUIRED

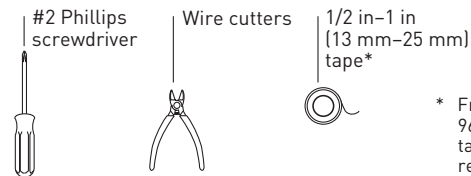

\* Frostex Plus  
9610 application  
tape is  
recommended.

- Additional tape or two 10 in (25 cm) cable ties may be used to secure ground-fault unit to pipe insulation.
- If you have any questions after reading this guide, call this toll-free number: (800) 545-6258
- Save this installation instruction and user guide.

### ⚠ WARNING:

#### FIVE IMPORTANT SAFETY WARNINGS

Follow all of these instructions to prevent fire or shock.

- Use the right end seal and plug.
  - Seal the cable only with the end seal provided. Do not use electrical tape.
  - Use the 9600 plug contained in this kit. It has special safety features.
  - Use the 9600 Plug Kit only with Frostex Plus heating cable.
- Keep the entire Frostex Plus system dry. This includes the insulation. If the system gets wet, pipes may freeze.
  - Use the system only on insulated residential pipes carrying water.
  - Do not use the system on buried pipes.
- The blue plastic cable and the metal braid must not be cut or damaged.
  - Before you begin, inspect the pipe. File and remove any sharp edges. Make sure the cable crosses only smooth, nonabrasive surfaces.
  - Where the system might be damaged by animals or objects, protect the complete system with a solid cover such as sheet metal or additional pipe insulation.
  - Do not use any wire or clamps to attach the cable to the pipe. Instead, use the Frostex Plus 9610 application tape or equivalent 1/2-1 in. tape or plastic cable ties.
- Inspect the cable periodically for damage. If you discover broken braid or other damage, immediately disconnect the system and replace the cable. Do not splice or repair a damaged cable. You must replace any damaged insulation or waterproof covering.
- Do not twist wires together or allow them to touch each other. If wires are allowed to touch, the non-replaceable fuse will blow and the system will not work.
- Do not install Frostex Plus cable close to flammable materials, liquids, or fumes.
  - Use only 1/2-inch or thicker fire-resistant foam or fiberglass pipe insulation.

**Step 1. Determine the length of cable you need**

**1A Collect the necessary information.**

**You will need to know the following:**

- Type of pipe (plastic or metal).
- Length and diameter of pipe.
- Lowest expected air temperature (disregard windchill).
- Number of valves and spigots.

**1B Use the cable length selection tables**

The Cable Length Selection Tables will tell you the length of cable you need per foot (Table 1) or per meter (Table 2). It will also tell you whether you will need to install the cable in a spiral or in a straight line.

**How to use the tables:**

- Decide on the lowest temperature you can expect in your area, down to  $-40^{\circ}\text{F}$  ( $-40^{\circ}\text{C}$ ).
- Measure the diameter of your pipe in inches.
- Under the heading for plastic or for metal pipes (whichever you are using), look down the first column to find your pipe diameter. Then look across to the box below the lowest expected temperature.

**Cable length selection tables**

**Table 1. English units** (based on use of 1/2 inch insulation)

Pipe Diameter	Lowest Expected Temperature			
	+20°F	0°F	-20°F	-40°F
<b>Plastic Pipes</b>				
1/2 in	1 ft	1 ft	1.5 ft	2 ft
	straight	straight	2 3/8 in	1 1/2 in
3/4 in	1 ft	1.1 ft	1.7 ft	2.3 ft
	straight	7 1/4 in	2 3/8 in	1 5/8 in
1 in	1 ft	1.3 ft	2 ft	2.7 ft
	straight	5 in	2 3/8 in	1 5/8 in
1 1/4 in	1 ft	1.6 ft	2.3 ft	3.2 ft
	straight	4 1/4 in	2 1/2 in	1 3/4 in
1 1/2 in	1 ft	1.8 ft	2.5 ft	3.6 ft
	straight	4 in	2 5/8 in	1 3/4 in
2 in	1 ft	2.1 ft	3 ft	4.3 ft
	straight	4 in	2 5/8 in	1 3/4 in
<b>Metal Pipes</b>				
1/2 in	1 ft	1 ft	1 ft	1.3 ft
	straight	straight	straight	3 1/8 in
3/4 in	1 ft	1 ft	1.1 ft	1.5 ft
	straight	straight	7 1/4 in	3 in
1 in	1 ft	1 ft	1.3 ft	1.8 ft
	straight	straight	5 in	2 3/4 in
1 1/4 in	1 ft	1.1 ft	1.6 ft	2.1 ft
	straight	11 1/2 in	4 1/4 in	2 7/8 in
1 1/2 in	1 ft	1.2 ft	1.8 ft	2.4 ft
	straight	9 in	4 in	2 3/4 in
2 in	1 ft	1.5 ft	2.2 ft	2.8 ft
	straight	6 5/8 in	3 3/4 in	2 7/8 in

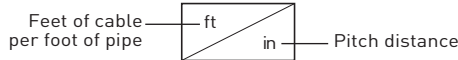

**Example 1 (English units)**

Suppose you are using plastic pipe with a diameter of 1 1/2 in. The lowest expected temperature in your area is  $-20^{\circ}\text{F}$ . The correct box in the selection table is this one:

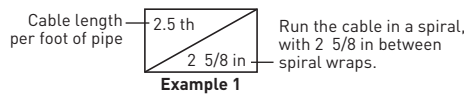

The first number in the box tells you the cable length (in feet) that you will need per foot of pipe. The second number indicates the recommended distance (in inches) between each spiral wrap of cable on the pipe.

For installations in a crock, add an additional 2 feet (60 cm) of heating cable.

**Table 2. Metric units** (based on 13 mm of insulation)

Pipe Diameter	Lowest Expected Temperature			
	-10°C	-20°C	-30°C	-40°C
<b>Plastic Pipes</b>				
1/2 in	1 m	1 m	1.5 m	2 m
	straight	straight	6	3.5
3/4 in	1 m	1.1 m	1.7 m	2.3 m
	straight	18.5	6	4
1 in	1 m	1.3 m	2 m	2.7 m
	straight	12.5	6	4
1 1/4 in	1 m	1.6 m	2.3 m	3.2 m
	straight	11	6.5	4.5
1 1/2 in	1 m	1.8 m	2.5 m	3.6 m
	straight	10	7	4.5
2 in	1 m	2.1 m	3 m	4.3 m
	straight	10	7	4.5
<b>Metal Pipes</b>				
1/2 in	1 m	1 m	1 m	1.3 m
	straight	straight	straight	8
3/4 in	1 m	1 m	1.1 m	1.5 m
	straight	straight	18.5	7.5
1 in	1 m	1 m	1.3 m	1.8 m
	straight	straight	12.5	7
1 1/4 in	1 m	1.1 m	1.6 m	2.1 m
	straight	29	10.5	7
1 1/2 in	1 m	1.2 m	1.8 m	2.4 m
	straight	23	10	7
2 in	1 m	1.5 m	2.2 m	2.8 m
	straight	17	9.5	7.5

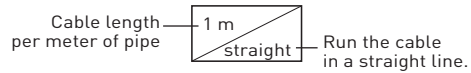

**Example 2 (Metric units)**

Suppose you are using metal pipe with a diameter of 3/4 in and the lowest expected temperature is  $-10^{\circ}\text{C}$ . The correct box is:

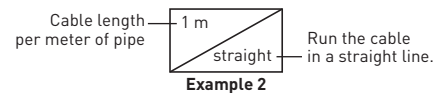

For installations in a crock, add an additional 2 feet (60 cm) of heating cable.

### 1C Calculate the total length of heating cable required

Multiply the cable length required per foot of pipe from step 1B by the length of your pipe. Add one extra foot (30 cm) for each valve in your line. Add one extra foot (30 cm) to install power connection. For installations in a crock, add an additional 2 feet (60 cm) of heating cable. After cutting the Frostex Plus cable to the length you need, proceed to Step 2.

#### Example (from 1B, Example 1):

If you have:

- 10 feet of 1 1/2-inch-diameter plastic pipe
- 1 ball valve

Cable length per foot of pipe (from Cable Length Selection Table) = 2.5 ft

Calculation of total length:

$$\begin{aligned} &25 \text{ feet (10 feet x 2.5 feet)} \\ &+ 1 \text{ foot (for ball valve)} \\ &+ 1 \text{ foot (for power connection)} \\ \text{Total length} &= 27 \text{ feet} \end{aligned}$$

Total length

For installations in a crock, add an additional 2 feet (60 cm) of heating cable.

**Note:** Do not use more than 50 feet (15 meters) of heating cable per plug. If the total calculated length exceeds 50 feet (15 meters), you will need additional 9800 FlexFit plugs and outlets. Longer circuit lengths will blow the nonreplaceable fuse in the 9800 FlexFit plug. If you require more than 50 feet per length (15 meters), call Raychem for information on other products.

## Step 2. Prepare the cable end and install the end seal

**Note:** The end seal can only be used once, so do not install it until step 2D.

### Heating cable construction

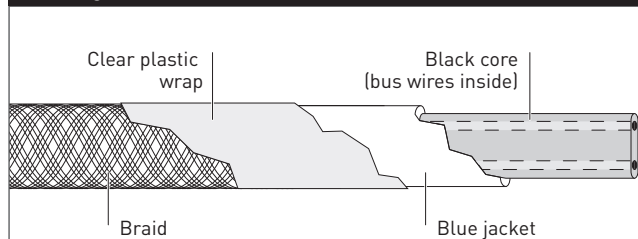

Follow steps 2A–2C to prepare the cable end and steps 2D and 2E to install the end seal.

### 2A Prepare the cable

- Cleanly cut off one end of the cable.

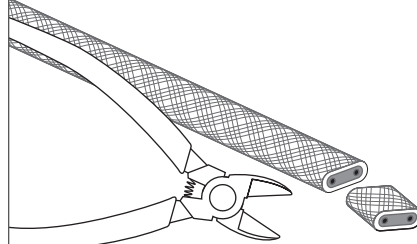

### 2B Push braid back

- Push the braid back 1 in (25 mm) from cable end.

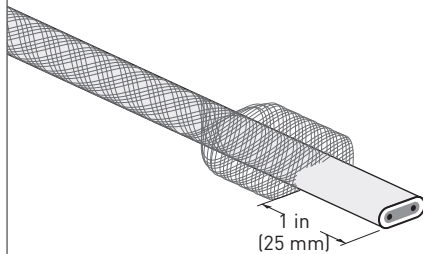

### 2C Remove plastic wrap

- Cut and remove the clear plastic wrap. Do not cut into the blue jacket.

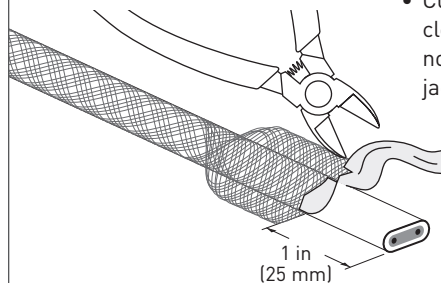

### 2D Install end seal

- Firmly push the end seal at least 3/4 in (2 cm) onto the heating cable. Some gel may ooze out.

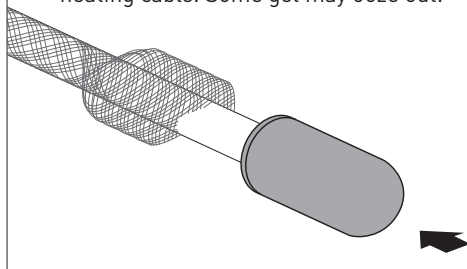

### 2E Secure braid

- Slide the braid up against the end seal and wrap it securely with the 4 in (10 cm) strip of white tape provided.

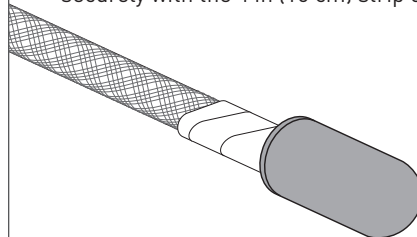

### Step 3. Install the 9800 FlexFit plug

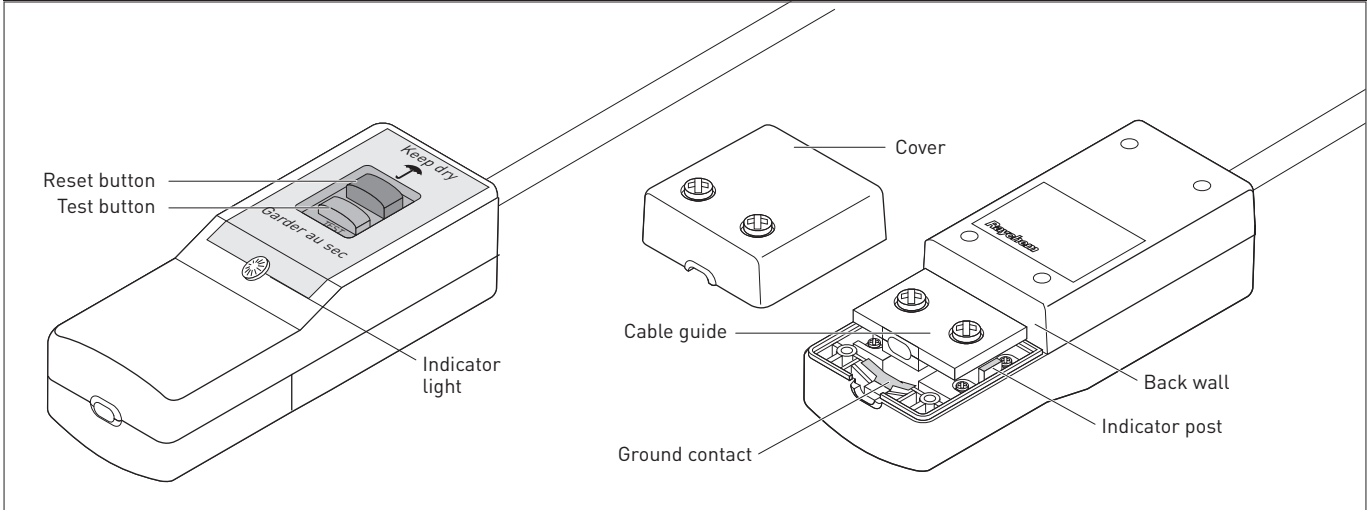

#### 3A Prepare the cable

Cleanly cut off the end of the cable. Push back braid 3/4 in (2 cm) and then twist the end of the braid around the cable to ensure braid strands are not sticking up.

**Note:** Clear plastic wrap does not need to be removed.

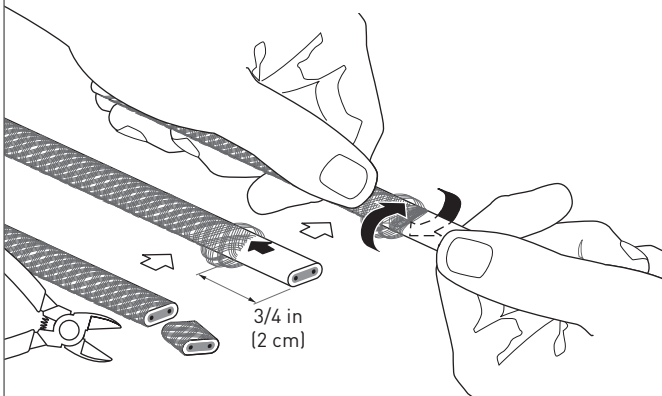

#### 3B Insert the cable

Insert the heating cable all the way into the cable guide until cable hits the back wall.

**CAUTION:** Make sure no braid wire strands enter the cable guide.

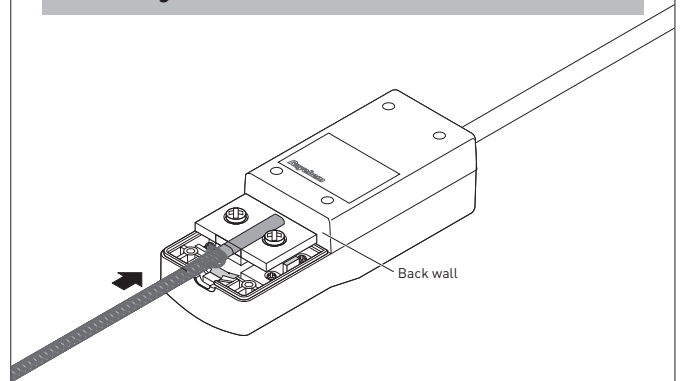

#### 3C Complete the connection

Screw down the cable guide, alternating between the two screws, until the cable guide is flush with the indicator posts and the screws bottom out.

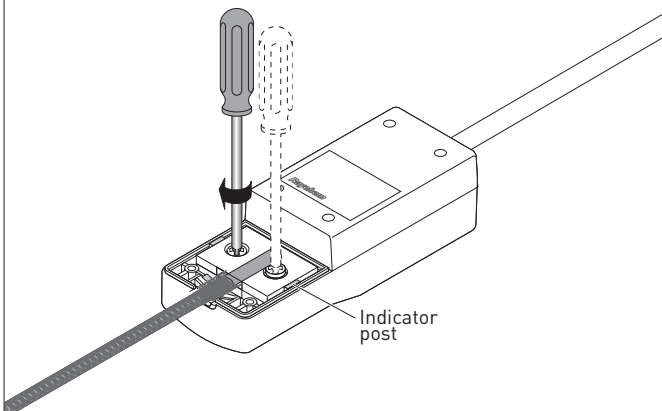

#### 3D Install cover

Install the cover by tightening the screws completely.

**Note:** The screws have a long travel distance before cover starts to close.

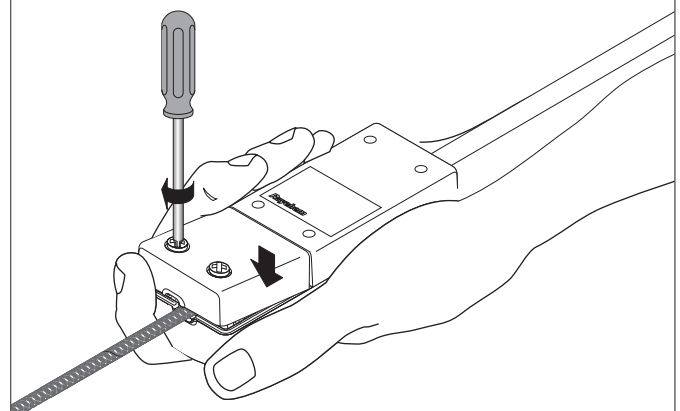

## Step 4. Attach the cable to the pipe

### 4A Prepare to wrap the cable

Begin the installation at the electrical outlet. Leave at least 1 foot (30 cm) of extra cable so the ground-fault unit can be secured to the outside of the thermal insulation, as shown in Figures 1 and 2. This will relieve any strain on the cable or plug. However, be careful not to leave cable hanging in a loose loop where it could be accidentally snagged and pulled out.

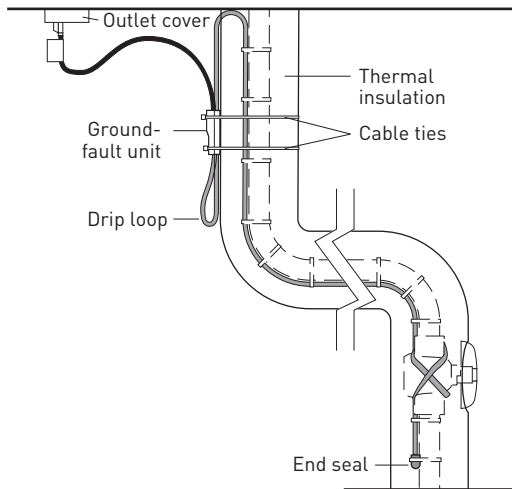

Figure 1. Typical manufactured housing installment

Make certain you have removed any old heating tapes and insulation.

**Important:** The ground fault unit and plug must be kept dry. It is important to include the drip loop to prevent water from getting into the ground fault unit.

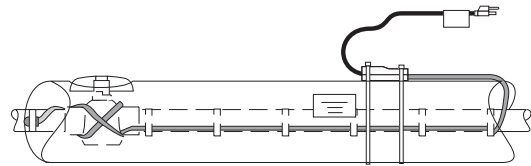

Figure 2. Typical installation

### 4B Wrap the cable

Using the method indicated in the Cable Length Selection Table, either wrap the cable around the pipe in a spiral or run it along the pipe in a straight line according to the directions that follow.

#### Spiral wrapping method

Wrap the cable in a spiral around the outside of the pipe, as shown in Figure 3.

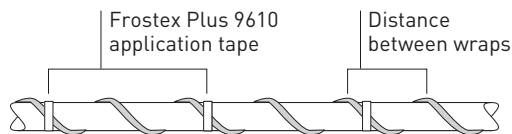

Figure 3. Spiral wrapping method.

Make sure to leave the required distance between wraps that was indicated in the Cable Length Selection Tables. Before you begin, you may want to mark the pipe at the correct intervals, using a marking pen.

#### Straight tracing method

Run the cable in a straight line approximately a third of the way up from the bottom of the pipe, as shown in Figure 4.

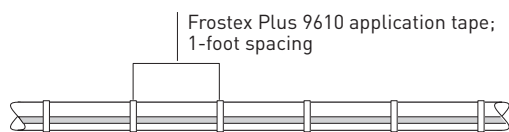

Figure 4. Straight tracing method.

### 4C Tape the cable and end seal to the pipe

- Fasten the cable to the pipe at 1-foot (30 cm) intervals, using two or three thicknesses of 9610 application tape or equivalent.
- Provide extra heat at valves and spigots by wrapping each with 1 foot (30 cm) of additional cable, overlapping as required.
- If you have excess cable at the end of your pipe, double it back along the pipe where the insulation will completely cover it as shown in Figure 5. Using 9610 application tape or equivalent, tape the end seal to the pipe as shown in Figures 1, 2, and 5.

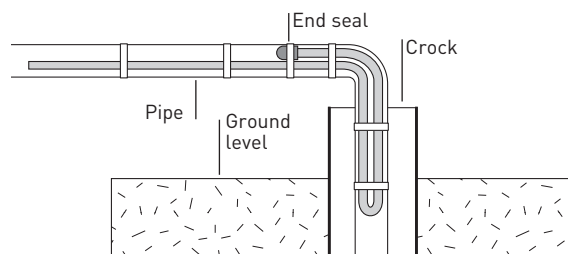

Figure 5. Excess cable doubled back.

**Important:** In a crock or standpipe, run the Frostex Plus cable down and back up the pipe (as shown in Figure 5), so that the **end seal is well above the ground level and will not be sitting in water.**

## Step 5. Install the insulation

Thermal insulation protects the Frostex Plus cable from damage and helps keep the pipes from freezing. Before you insulate, be

sure the Frostex Plus cable is undamaged—no nicks or cuts—and the braid is intact. Replace the cable if necessary.

### 5A Cover the system with the insulation

Cover the pipe, cable, connections, valves, and spigots with clean, dry, waterproof, fire-retardant thermal insulation such as closed cell foam insulation, as shown in Figure 6. The insulation must be at least 1/2 in (13 mm) thick. Secure the 9800 FlexFit plug to the insulation with tape or cable tie, being careful not to cover light or test buttons.



Figure 6. Thermal insulation.

- Do not leave the cable exposed, except for the short distance from the pipe to the power connection.
- Fully insulate and weatherproof all exposed piping. Put additional insulation on areas that cannot be heat traced.

### 5B Waterproof the insulation

Make sure the thermal insulation is waterproof. Install a watertight sleeve and a solid cover or a barrier such as polyethylene sheeting around the insulation wherever there is any chance that the insulation might get wet.

### 5C Install the warning label

Install the orange warning label on the insulation near the electrical outlet, as shown in Figure 6.

Additional labels and installation tape are available from Raychem in the Frostex Plus 9610 kit.

## Step 6. Start up the system

### 6A Plug in the cable

After installing the heating cable and insulation, remove the clear label that covers the test and reset buttons. Then, plug the 9800 FlexFit plug into a grounded and properly installed outlet.

- If the Frostex Plus cable length is longer than 40 feet and the air temperature is lower than 30°F, run water through the pipe before plugging in the unit. This will warm up the pipe and help avoid blowing the nonreplaceable fuse in the 9800 FlexFit plug.
- The signal light will go on indicating that the ground-fault protection device and the fuse are working properly. However, the light does not confirm that the heating cable is properly connected. See Step 7 for “Testing the System.”

### 6B Test the plug

- Press the white test button. The red reset button should pop out from the surface of the plug and the signal light should go out.
- When the red reset button pops out, push it in to restore power and proceed to step 7.
  - If the red reset button fails to pop out, skip to “Troubleshooting”.
  - If the red reset button pops out immediately but cannot be reset, skip to “Troubleshooting”.
  - If the signal light does not light, skip to “Troubleshooting”.

## Step 7. Test the cable's resistance

Test the system using one of the two following procedures.

### 7A Test the water temperature

After plugging in the system, wait about an hour. Turn on a water tap on the Frostex Plus-protected pipe and test the temperature of the water. It should feel warm almost immediately because the water heated by the Frostex Plus cable will be briefly running through the pipe.

- If the water is warm, you have completed the installation.
- If the water is not warm, skip to “Troubleshooting”.

### 7B Test the cable's resistance

It is possible to test the resistance of Frostex Plus heating cable using a multimeter. Follow these steps:

- Be sure the 9800 FlexFit plug is unplugged.
- Push in the red reset button on the plug.
- Connect the two lead wires on the meter to the two flat prongs on the plug. The meter reading should be between 2 and 20,000 ohms.
  - If your reading is within this range, you have completed the installation.
  - If your reading is not within this range, repeat Step 3, “Install the 9800 FlexFit plug” (beginning on page 4) and retest.
  - If your reading is still not within this range, or if you have any questions, call Pentair Thermal Management for technical support at (800) 545-6258.

## Periodic Inspections

### Each month

- Test the 9800 FlexFit plug as described in Step 6B.

### Periodically

- Each time you plug in the system, and at least once a year, do the following:
- Check the entire Frostex Plus system for signs of damage.
  - Inspect any exposed portion of the cable for evidence of cuts, nicks, abrasions, gnawing by animals and any other physical damage.
  - If there is damage, immediately replace the damaged cable system and thermal insulation. Do not attempt to repair any part of the heating cable system.
- After a thorough inspection, start up the system and test the 9800 FlexFit plug and system as described in Steps 6 and 7.

## Troubleshooting

### **Problem: The red button pops out immediately when plugged in or will not reset.**

What to do: A strand of braid may have entered the cable guide during step 3B

- Unplug the 9800 FlexFit Plug.
- Remove the cover (as installed in step 3D).
- Unscrew the two screws of the cable guide (as installed in step 3C).
- Using a flat blade screwdriver, gently pry the cable guide up until the heating cable can be removed.
- Reinstall the screws completely into the cable guide before re-attaching.
- Repeat installation steps 3A–3D, ensuring no braid strands enter the cable guide during Step 3B.
- Repeat Step 6 “Start up the system”.

**Note:** If the 9800 FlexFit Plug red test button continues to pop out or signal light does not light, your system is damaged and must be replaced.

### **Problem: The signal light does not light up.**

What to do: Check to be sure the outlet has power. If you are not certain how to do this, call a professional service person.

Note: If the outlet has no power, correct the problem, then follow Step 6, “Start up the system.”

**Note:** If the outlet has power but the signal light still does not light up after you conduct the test described in Step 6B, “Test the plug,” the internal nonreplaceable fuse is blown. This means the Frostex Plus system is damaged and must be replaced.

### **Problem: The 9800 FlexFit plug does not trip (red button does not pop out).**

What to do: Check to be sure the outlet has power. If you are not certain how to do this, call a professional service person.

- If the outlet has no power, correct the problem, then follow the instructions in Steps 6 and 7.
- If the outlet has power but the 9800 FlexFit plug still fails to trip, the Frostex Plus system is damaged and must be replaced.

### **Problem: The heating cable fails to warm up or water is not warm after testing the system.**

What to do: The heating cable may not be fully inserted into the cable guide, or the guide may not be screwed down completely.

- Unplug the 9800 FlexFit Plug.
- Remove the cover (as installed in step 3D).
- Unscrew the two screws of the cable guide (as installed in step 3C).
- Using a flat blade screwdriver, gently pry the cable guide up until the heating cable can be removed.
- Reinstall the screws completely into the cable guide before re-attaching.
- Repeat installation steps 3A–3D, ensuring no braid strands enter the cable guide during Step 3B.
- Repeat Step 6 “Start up the system.”

## Limited Warranty (United States)

Pentair Thermal Management warrants that your Frostex Plus heating cable will operate properly for a period of 24 months from the day you purchase it. Some states do not allow limitations on how long an implied warranty lasts, so the above limitation may not apply to you. THIS WARRANTY IS GIVEN TO THE FIRST CONSUMER PURCHASER ONLY.

PENTAIR THERMAL MANAGEMENT DISCLAIMS ALL OTHER WARRANTIES, EXPRESS OR IMPLIED, INCLUDING THE IMPLIED WARRANTIES OF MERCHANTABILITY AND FITNESS FOR A PARTICULAR PURPOSE.

If your Frostex Plus heating cable fails to operate for any reason, other than misuse, failure to follow instructions, abuse, or external damage, simply return the product at your expense to your dealer, or mail it, postage prepaid, to Pentair Thermal Management at the address on the back cover, and you will receive a replacement Frostex Plus heating cable free of charge. Be sure to include your name, address, and zip code; your dealer's name and address; and your date of purchase. REPLACEMENT OF THE HEATING CABLE IS YOUR EXCLUSIVE REMEDY. THERE ARE NO CASH REFUNDS.

PENTAIR THERMAL MANAGEMENT SHALL NOT BE LIABLE FOR ANY INJURY, LOSS, OR DAMAGE—DIRECT, INDIRECT, INCIDENTAL, OR CONSEQUENTIAL—ARISING OUT OF YOUR INABILITY TO USE, OR FAILURE OF, ANY FROSTEX PLUS HEATING CABLE FOR ANY REASON EVEN IF THE CABLE IS NOT REPLACED. THE EXCLUDED ITEMS INCLUDE THE COST OF REMOVAL OF A DEFECTIVE HEATING CABLE AND THE COST OF INSTALLATION OF A REPLACEMENT HEATING CABLE. Some states do not allow the exclusion or limitation of incidental or consequential damages, so the above limitation or exclusion may not apply to you.

**Frostex Plus heating cables are consumer products intended for residential aboveground water-pipe freeze protection in dry locations and this warranty does not, under any circumstances, extend to any industrial or commercial application.**

This warranty gives you specific legal rights, and you may also have other rights that vary from state to state.

## Limited And Non Assignable Warranty (Canada)

Pentair Thermal Management warrants to the original purchaser only ("purchaser") that each Frostex Plus heating cable ("Frostex cable") purchased by such purchaser from Pentair Thermal Management, or from any Pentair Thermal Management authorized distributor ("Pentair Thermal Management distributor"), shall be free from defects in material and workmanship ("deficiency") for a period of 24 consecutive months immediately following the date of such purchase by purchaser ("warranty period"). Should any deficiency be discovered within such Frostex cable during the warranty period, Pentair Thermal Management shall, at Pentair Thermal Management's option, either repair or replace such Frostex cable within a reasonable period of time at Pentair Thermal Management's expense ("limited warranty").

This limited warranty is conditional upon: (i) purchaser returning to Pentair Thermal Management, or to the Pentair Thermal Management distributor, each Frostex cable containing a deficiency prior to the expiry of the warranty period; (ii) Pentair Thermal Management confirming to Pentair Thermal Management's satisfaction that such deficiency exists and occurred in the course of proper and normal use of the Frostex cable and that such deficiency was not caused by the acts or omissions of any party or parties other than Pentair Thermal Management, including without limitation, though improper location, installation, accident, misuse, neglect, or alteration of such Frostex cable by any party or parties other than Pentair Thermal Management or the Pentair Thermal Management distributor.

**Each Frostex cable is sold for use in providing residential aboveground waterpipe freeze protection in dry locations. This limited warranty shall not apply, under any circumstances, to any Frostex cable used in any industrial or commercial application.**

**This limited warranty is provided by Pentair Thermal Management, and accepted by purchaser, in lieu of all other warranties, conditions, and guarantees of every kind whatsoever pertaining to the Frostex cable purchased by the purchaser, whether express, or implied by statute, common law, custom, course of dealing, usage of trade or otherwise. All other warranties, conditions, and guarantees of every kind are excluded by**

**Pentair Thermal Management to the fullest extent permitted by law, including without limitation, all warranties of description, quality, merchantability, merchantable quality, fitness for particular purpose, suitability, operation, or non infringement.**

No warranty or warranties of any kind are provided by Pentair Thermal Management with respect to any information, advice, recommendations, assistance, and/or services provided to the purchaser by Pentair Thermal Management, or by any Pentair Thermal Management distributor, with respect to the design, operation, location, or installation of any Frostex cable sold to purchaser.

### Exclusion and limitation of liability

Pentair Thermal Management shall have no liability whatsoever to the purchaser for: (i) the cost of procurement of substitute products or services; (ii) any loss, damage, destruction, or loss of use of facilities, equipment, or property; (iii) any loss of revenue, loss of use of revenue, lost profits, or loss of anticipated profits; (iv) any injury to persons or death; nor (v) any special, incidental, indirect, consequential, economic, aggravated, exemplary, or punitive damages; whether based in contract, strict liability, tort, or upon any other theory of liability, howsoever arising. This limitation of liability shall apply even if Pentair Thermal Management has been advised of the possibility of any and all such costs, losses, or damages arising.

Pentair Thermal Management's total liability to purchaser for: (i) each breach (including fundamental breach) or default in performance by Pentair Thermal Management of any obligation to the purchaser related to this limited warranty, at law, or otherwise, and/or (ii) each defect, inadequacy, omission, or deficiency in any Frostex cable; shall not, in the aggregate exceed the total amount received by Pentair Thermal Management, or by the Pentair Thermal Management distributor, from the purchaser related to the purchase of such Frostex cable, whether such liability is based in contract, strict liability tort (including without limitation, negligence failure to warn) or upon any other theory of liability, howsoever arising.



WWW.THERMAL.PENTAIR.COM

### NORTH AMERICA

Tel: +1.800.545.6258  
Fax: +1.800.527.5703  
Tel: +1.650.216.1526  
Fax: +1.650.474.7711  
thermal.info@pentair.com

### EUROPE, MIDDLE EAST, AFRICA

Tel: +32.16.213.511  
Fax: +32.16.213.603  
thermal.info@pentair.com

### ASIA PACIFIC

Tel: +86.21.2412.1688  
Fax: +86.21.5426.2917  
cn.thermal.info@pentair.com

### LATIN AMERICA

Tel: +55.11.2588.1400  
Fax: +55.11.2588.1410  
thermal.info@pentair.com

Pentair, Frostex and Frostex Plus are owned by Pentair or its global affiliates. All other trademarks are the property of their respective owners. Pentair reserves the right to change specifications without prior notice.