

WARNING! Read all important information notices on pages 3–5

2-519.6
5H723536A

HEX5 Series

Installation, Parts, Service, and Maintenance Manual
60 Hz Models only



Model Coding

HEX5 - 480 3 60 - 350 - W T

Model Series | Heater Voltage (208V, 240V, 480V, 600V) | Phase (1, 3) | Hertz (60) | Heater Kilowatts (350) | Welded Core | Thermostat/Option (T)

- T – XT-311 Thermostat with slim junction box
- XT-411 Thermostat with large junction box
- D – Built-in disconnect
- P – Built-in pilot light
- S – 3-way switch

- H – Unit with high “off” de-energized ambient temperatures
- C – Heresite® coating
- A – Stainless steel cabinet
- U – Continuous fan
- B – Low ambient option -50°F (-50°C)
- L – Large junction box



UL approved Locations

The Electric Forced Air Heaters are UL_{US} listed certified for the following locations: Class I, Divisions 1 & 2, Groups C & D; Class II, Division 1, Groups E, F & G; Class II, Division 2, Groups F & G; Class I, Zones 1 & 2, Groups IIA & IIB; Temperature Code T3B 329°F (165°C)

For details of hazardous locations with potential for explosion, refer to the Canadian Electrical Code, Part 1, Section 18 or National Electrical Code articles 500–516.

TABLE OF CONTENTS

A. Heater Maintenance Checklist	3
A.1 Preventative Maintenance Grid	3
A.2 Periodic	4
A.3 Annual	4
B. Important Notices	5
C. Troubleshooting Tips	6
D. Installation	7
D.1 Mechanical	7
D.2 Electrical	9
D.3 Wiring Schematics	11
E. HEX5 Technical Data	12
E.1 60 Hz Electric Heaters	12
F. Specifications	14
F.1 60 Hz Models	14
G. Parts Assembly Diagram	16
H. Parts List	17
I. Repair & Replacement	18

A. HEATER MAINTENANCE CHECKLIST

Heater Model _____ Date of Maintenance _____

Serial Number _____ Maintenance Done By _____

Comments _____

WARNING

Disconnect heater from power supply at integral disconnect or fuse box before opening enclosures or servicing heater.

IF INTEGRAL DISCONNECT IS BEING SERVICED, verify that power has been disconnected at fuse box or main panel.

Lock the switch in the **“OFF”** (open) position and/or tag the switch to prevent unexpected power application.

This heater should only be serviced by personnel with heating and hazardous location equipment experience.

A.1 Preventative Maintenance Grid

Cells of the grid with check boxes inside are the minimum maintenance measures required to be performed at the indicated time periods.

To-Do	Description	Regular Service				Severe Service			
		Annual Start Up	Monthly	Every 3 Months	Every 6 Months	Annual Start Up	Monthly	Every 3 Months	Every 6 Months
Clean	Remove dust using compressed air. Do not spray with water or solvents. Do not immerse in water or solvents. Clean the following: 1. Motor 2. Louvers 3. Finned Tubes 4. Fan 5. Fan Guard	<input type="checkbox"/>		<input type="checkbox"/>		<input type="checkbox"/>		<input type="checkbox"/>	
Check	1. Motor for smooth, quiet operation 2. Louvers for proper angle and tightness 3. All explosion-proof covers for tightness 4. Pressure relief device for signs of leakage. See Figure 1, page 5 and refer to A.3 Annual, page 4 for further instructions.	<input type="checkbox"/>				<input type="checkbox"/>		<input type="checkbox"/>	
Electrical Inspection	1. Inspect all terminal connections and conductors.* Tighten loose connections. Replace conductors with damaged insulation and frayed wiring.*	<input type="checkbox"/>			<input type="checkbox"/>	<input type="checkbox"/>		<input type="checkbox"/>	
	2. Inspect contactor contacts: If badly pitted, burned or welded shut, replace with factory supplied contactor.*	<input type="checkbox"/>			<input type="checkbox"/>	<input type="checkbox"/>		<input type="checkbox"/>	
	3. Check fuses: The correct fuse rating and type are printed on the circuit board. Always ensure a backup fuse is available on the PCB.*	<input type="checkbox"/>			<input type="checkbox"/>	<input type="checkbox"/>		<input type="checkbox"/>	
Mechanical Inspection	1. Fluid leakage: Inspect the Pressure Release Valve (PRV) label indicator for signs of rupture and degradation. If any fluid leakage occurs from the heater, disconnect it from the power supply and replace the core immediately.*		<input type="checkbox"/>			<input type="checkbox"/>	<input type="checkbox"/>		
	2. Enclosures: The interiors of each enclosure must be clean, dry, and free of foreign materials.*	<input type="checkbox"/>				<input type="checkbox"/>		<input type="checkbox"/>	
	3. Motor shaft bearing and play: If the motor does not run quietly and smoothly and has excessive play, replace the motor.*	<input type="checkbox"/>				<input type="checkbox"/>		<input type="checkbox"/>	

*For drilling rigs, this should be done every rig re-location.

A.2 Periodic (before and as required during heating season)

- **Clean**

- Motor
- Louvers
- Finned Tubes
- Fan
- Fan Guard

- **Check**

- Motor for smooth, quiet operation
- Louvers for proper angle and tightness
- All explosion-proof covers for tightness
- Pressure relief device for signs of leakage. See Figure 1, page 5 and refer to Annual, page 4 (Fluid leakage), for further instructions.

A.3 Annual (before heating season)

- **Mechanical Check**

- Fluid leakage.** The heater core is vacuum charged and contains propylene glycol. Inspect the Pressure Relief Valve label indicator for signs of rupture and degradation. If the paper is torn, disintegrated or otherwise compromised this is an indication that fluid has leaked from the core. If any fluid leakage occurs from the heater, disconnect it from the power supply and have the core replaced. A factory supplied exchange core can be shipped immediately from stock. Refer to Section Repair & Replacement, page 18 for details.
- All enclosures.** Interior of enclosures must be clean, dry and free of foreign materials. Threaded covers must be installed and hand tight.

Note: Enclosure joints are metal to metal. Do not use gasket material or sealant in joints. A grease is applied to the joints at the factory and should be left intact.
- Motor shaft bearing play.** Replace motor if play is excessive, or if motor does not run quietly and smoothly. Motor bearings are permanently lubricated.
- Fan.** Replace immediately if cracked or damaged.
- Louvers.** Screws should be tight. Louvers shall not be fully closed or override stops.
- Tightness of all hardware.** All nuts and bolts, including mounting hardware, must be tight.
- Turn heater on for a minimum of five minutes.** Check for warm air exiting heater through louvers. Crackling or pinging noises within heater during start-up are normal.

- **Electrical Check**

- All terminal connections and conductors.** Tighten loose connections. Conductors with damaged insulation must be replaced.
- Inspect contactor contacts.** If badly pitted, burned or welded shut, replace with factory supplied contactor. For severe duty conditions such as arctic duty or drilling rigs, Modine recommends the contactor be replaced every two years.
- Fuses.** Fuse rating and type are on printed circuit board. Correct fuse must be in the active fuse clip. It is recommended that a spare fuse be stored in the spare fuse clip.
- All explosion-proof conduits.** Replace damaged conduits. All threaded conduit connections must have a minimum 5 turns engagement. Straight threaded conduit must protrude a minimum of 1/16" (1.6 mm) inside enclosures. Taper threaded connections must be at least hand tight.
- Electrical resistance on all load side legs.** Reading should be balanced ($\pm 5\%$).

B. IMPORTANT NOTICES

WARNING

Read and adhere to the following. Failure to do so may result in severe or fatal injury. WARRANTY WILL BE VOID.

1. Read and follow all instructions in this manual.
2. Heater is to be used only in atmospheres having an ignition temperature higher than the heater's maximum rated operating temperature as shown on the heater data plate. Refer to applicable electrical codes for additional information.
3. Heater to be used only in the hazardous locations indicated on the heater's data plate.
4. Heater is for dry indoor use only. Do not immerse in water. Do not store or use in areas exposed to rain or snow.
5. Heater is to be connected and serviced only by a qualified electrician experienced with hazardous location equipment.
6. Installation and wiring of the heater must adhere to all applicable codes.
7. Disconnect heater from power supply at integral disconnect or fuse box before opening enclosures or servicing heater. IF INTEGRAL DISCONNECT IS BEING SERVICED, verify that power has been disconnected at fuse box or main panel. Lock the switch in the "OFF" (open) position and/or tag the switch to prevent unexpected power application.
8. This heater is equipped with a single bimetal overtemperature high-limit. It is of the automatic reset type and therefore the heater may restart without warning. The heater is not to be operated with the high-limit disabled or disconnected from the control circuit.
9. Venting pressure of the pressure relief valve (PRV) is factory set. Do not tamper with lock nut. (See Figure 1, page 5.)
10. Do not tamper or remove warning label indicator on the PRV.
11. Operate the heater only while it is permanently mounted in an upright position. Refer to Section D. Installation, page 7 for details.
12. Heater must be kept clean. When operating in a dirty environment, regularly clean the finned tubes, fan, and fan guard. Follow the recommended maintenance procedures. Refer to Section A. Heater Maintenance Checklist, page 3 for details.
13. The heater core is vacuum charged and contains propylene glycol. If any fluid leakage occurs from the heater, disconnect it from the power supply and have the core replaced with a factory supplied core. Refer to Section I. Repair & Replacement, page 18 for details.
14. Do not operate the heater with any of the louvers fully closed or overriding their stops.
15. Do not operate the heater in atmospheres corrosive to steel or aluminum.
16. Do not operate heater in ambient temperatures above 104°F (40°C).
17. Use factory approved replacement parts only.
18. See applicable electrical codes for seal requirements in field installed conduits. Factory installed conduits require no further sealing.
19. Crackling or pinging noises within the heater core during start up may occur. This is normal.
20. Air discharge near the bottom of the heater may be warmer than the top. This is normal.
21. If there are any questions or concerns regarding the heater, contact the factory. Refer to the back cover of this manual for details.

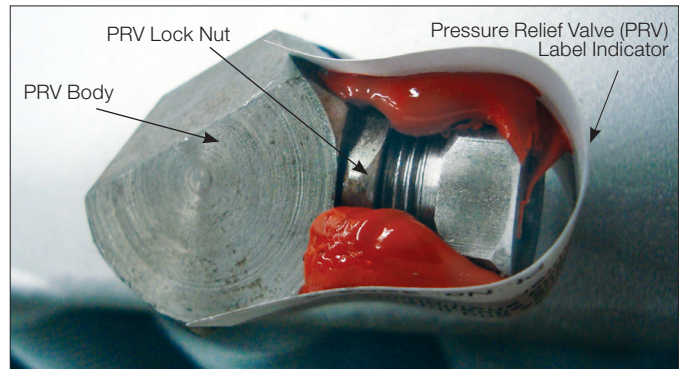

Figure 1

C. TROUBLESHOOTING TIPS

1. Heater is not operating.
 - 1.1 Check all fuses in heater control box.
 - 1.2 Check remote disconnect switch and circuit breaker.
 - 1.3 Check voltage supplied to the heater – refer to the heater data plate for voltage requirements.
 - 1.4 Check thermostat by turning it and check continuity with a multimeter.
 - 1.5 Check the condition of the disconnect switch if the heater is so equipped. Measure continuity through the disconnect by engaging the switch.
 - 1.6 Verify that there is a jumper wire present between terminals 5 and 6 on the terminal block located in the control box.
2. Contactor is chattering.
 - 2.1 Check supply voltage.
 - 2.2 Check wiring connections. Tighten all loose electrical connections.
 - 2.3 Check thermostat for continuity (See 1.4, page 6). If thermostat does not break continuity replace thermostat.
3. Contactor is burned or welded.
 - 3.1 Check the contactor for burn marks and blackening. Replace the contactor.
 - 3.2 Check incoming power to the heater to ensure there are no voltage fluctuations.
4. Heat exchanger is dirty.
 - 4.1 Clean the heat exchanger using compressed air.
5. PRV has released.
 - 5.1 If there are signs that the PRV has released fluid, PRV indicator is broken, blackening around the PRV exit hole, or there are fluid stains visible on the top louver, shut the unit down immediately.
 - 5.2 Check for restricted air flow, bad motor, broken thermostat or malfunctioned high limit.
6. Heater is cold on top and warm on bottom.
 - 6.1 The core may have lost its vacuum. Check the PRV for signs of loss of fluid and verify that the PRV label indicator is not broken. If PRV has released, send the unit in for repair or replace the core.
 - 6.2 If the PRV does not indicate loss of fluid, the heater should operate normally.
 - 6.3 The ambient temperature may be too low. If the ambient temperature is very cold the top of the core will be colder than the bottom – this is normal.
7. Unit cycles on high limit – unit turns on and turns off within less than 5 minutes.
 - 7.1 Check and see if the PRV has released fluid. Core may have lost most or all of its fluid. If PRV has released, send the unit in for repair or replace core.
- 7.2 The core may be dirty, fan may not be working or may be turning the wrong way (the fan must rotate clockwise as seen from the front of the unit) objects may be stuck in the heat exchanger for drying or warming up – remove any items from the exchanger.
8. The Ground Fault Interrupter (GFI) trips on the main panel, or heater blows fuses.
 - 8.1 Check that you have a fuse of the proper amperage rating.
 - 8.2 Check for loose or frayed wiring.
 - 8.3 If condition is not observable, send heater in for repair.
 - 8.4 Change sensitivity of GFI.
9. The fan is turning but very little air comes from the front of the heater.
 - 9.1 Check fan rotation and ensure that the fan turns clockwise as seen from the front of the heater. Refer to the Installation section below for more information.
 - 9.2 Check motor winding resistance and verify that they are balanced.
 - 9.3 Check fan blade set screws to ensure fan blade is not loose on the motor shaft.

D. INSTALLATION General Guideline for Installation and Wiring

All applicable codes must be adhered to. For optimum heating, the heater should be installed as follows:

D.1 Mechanical

1. Location

- 1.1 There are no obstructions that may impede the heater's air inlet or discharge.
- 1.2 The air discharge is directed into open areas and not at occupants.
- 1.3 The air discharge is not directed at a thermostat.
- 1.4 The air discharge is directed across areas of heat loss, such as doors and windows (see Figure 2, page 7).
- 1.5 The air discharge is directed along and at a slight angle toward exterior walls (see Figure 2, page 7).
- 1.6 If equipment freeze protection is important, direct air discharge at equipment.
- 1.7 Air discharge streams support each other and create a circular air flow. It is not required that the heater's air throw reaches the next heater (see Figure 2, page 7).

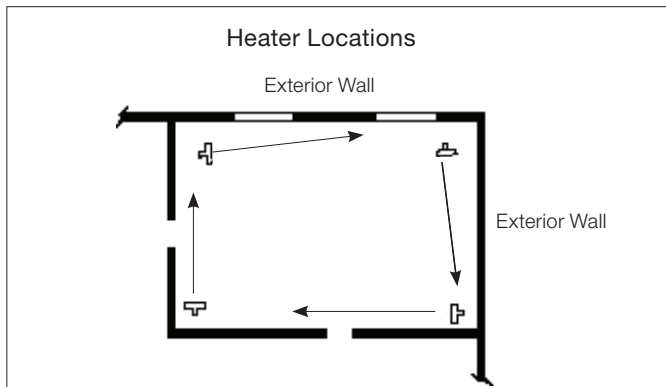

Figure 2

2. Mounting

- 2.1 The heater must be permanently mounted in a level, upright position for operation. See Figure 3, Figure 4, and Figure 5 on page 7 and 8 for maximum tilt angles, installation clearances, and physical dimensions. For ease of installation, a variety of mounting kits are available from the factory.
- 2.2 The mounting structure must be strong enough to:
 - Support the heater's weight (refer to Section F. Specifications, page 14).
 - Provide sufficient stiffness to prevent excessive vibration.
 - Withstand harsh situations such as transportable installations.

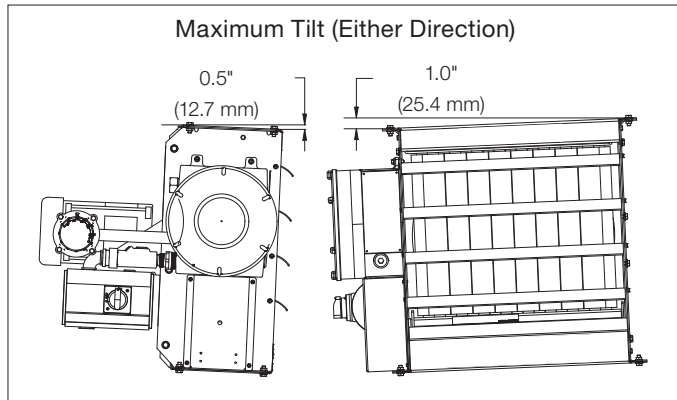

Figure 3

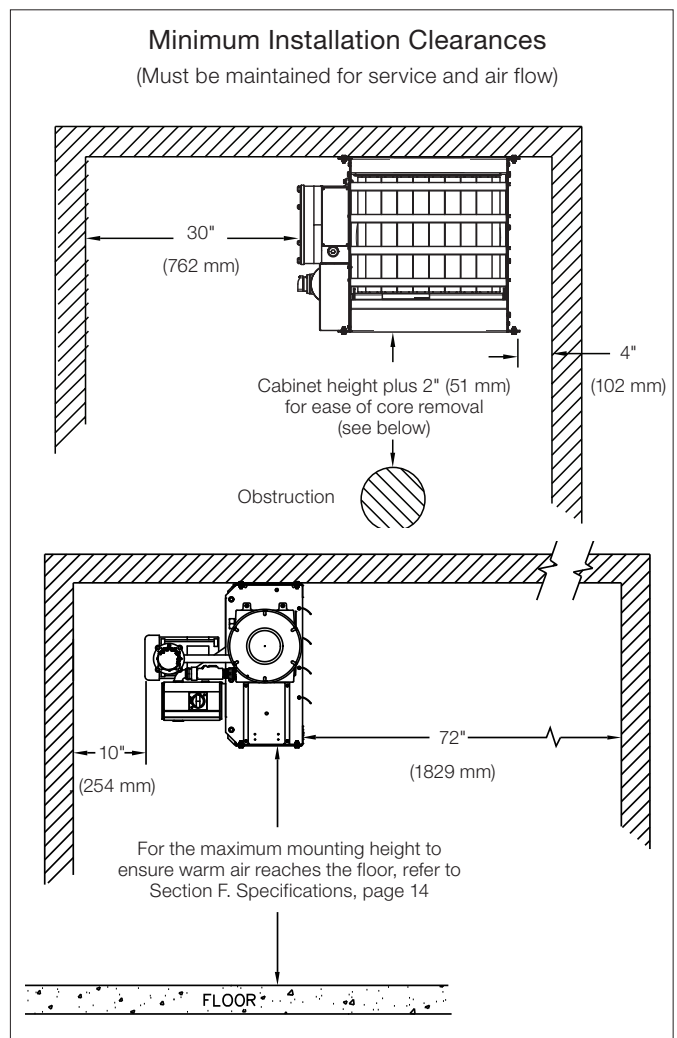

Figure 4

Dimensional Tolerances $\pm 1/8"$ [± 3 mm]
Unless otherwise specified.

DIM.	kW	kW			DIM. TOL. \pm
		2.5-10	12.5-20	20.9-35	
A	in.	7	7	7	1/8
	mm	178	178	178	3
B	in.	18-3/16	22-5/16	26-1/4	1/8
	mm	462	566	667	3
C	in.	27	31	35	3/16
	mm	686	787	889	4
D	in.	19	23	27	1/8
	mm	484	586	688	3
E	in.	19-7/16	23-7/16	27-7/16	3/8
	mm	492	596	697	10
F	in.	17-1/2	19-1/2	21-13/16	5/16
	mm	444	495	554	8
G	in.	24-5/8	28-5/8	32-5/8	3/16
	mm	625	727	828	4

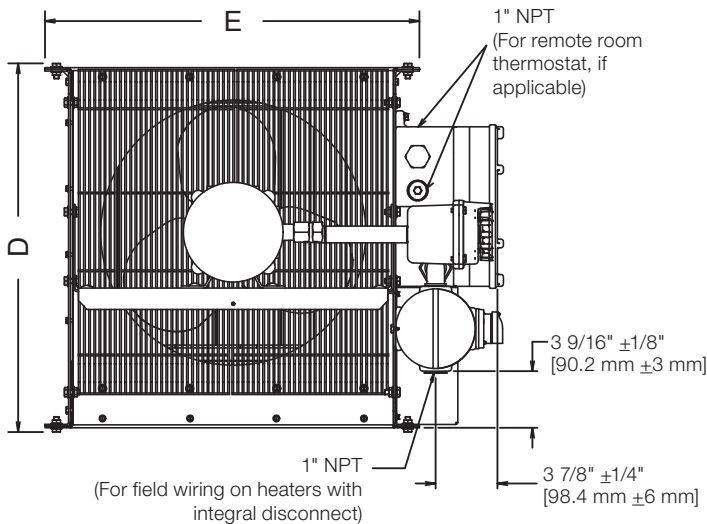
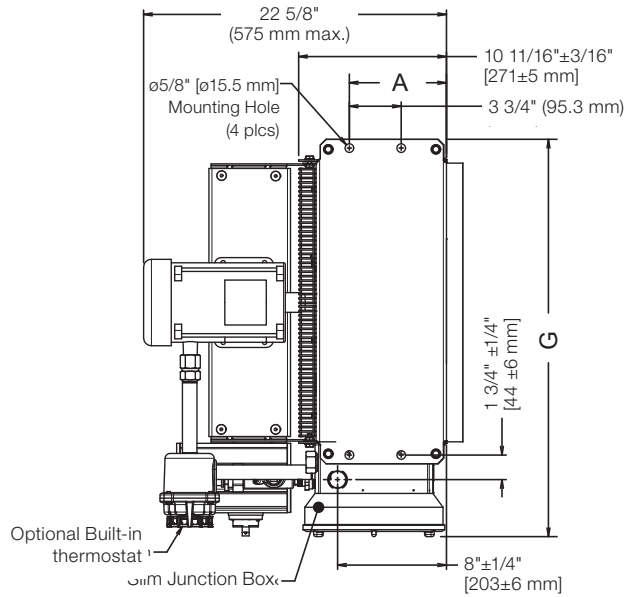
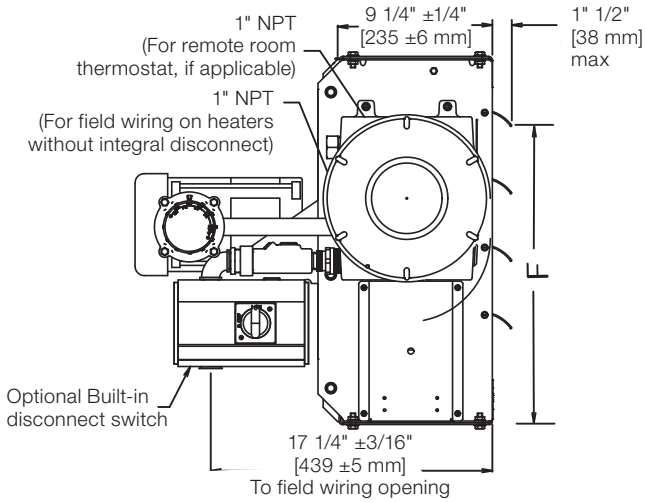
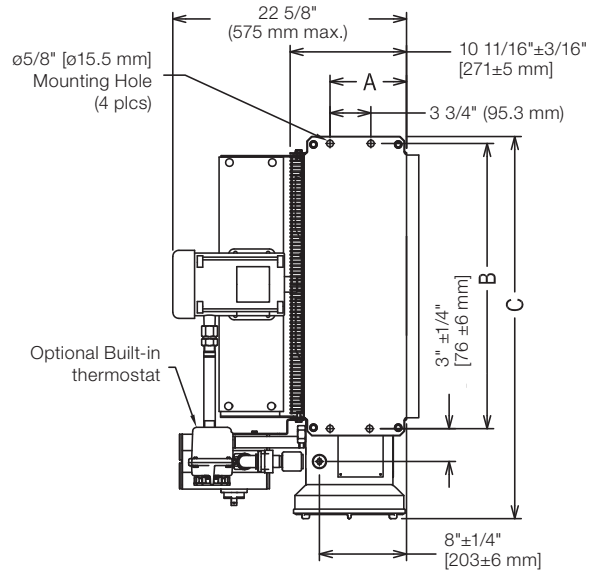

Figure 5

D.2 Electrical

WARNING

Disconnect heater from power supply at integral disconnect or fuse box before opening enclosures or servicing heater.
IF INTEGRAL DISCONNECT IS BEING SERVICED, verify that power has been disconnected at fuse box or main panel. Lock the switch in the "OFF" (open) position and/or tag the switch to prevent unexpected power application. Installation and wiring of the heater must adhere to all application codes.

1. General
 - 1.1 Use only copper conductors and approved explosion-proof wiring methods during installation. Refer to Section E. HEX5 Technical Data, page 12 to 13 and heater data plate for conductor rating.
 - 1.2 External overcurrent protection is required. Refer to Section E. HEX5 Technical Data, page 12 to 13 and heater data plate for voltage, frequency amperage, and phase. Supply voltage is to be within 10% of the data plate voltage.
 - 1.3 The heater must be installed by qualified personnel in strict compliance with electrical codes.
 - 1.4 All heaters come factory prewired and ready for direct connection to the power supply leads.
 - 1.5 The heater must be individually fused, preferably with Class J time-delay fuses for maximum safety. Unless stated otherwise in your local code, fuse size shall be 125% of line current or next size larger.
2. Field Wiring
 - 2.1 The supply conductors, ground conductor, and room thermostat conductors (see D.3 Wiring Schematics, page 11) all pass through the 1" NPT opening (see Figure 6, page 9) and are to be wired into the control enclosure (see Figure 7, page 9).

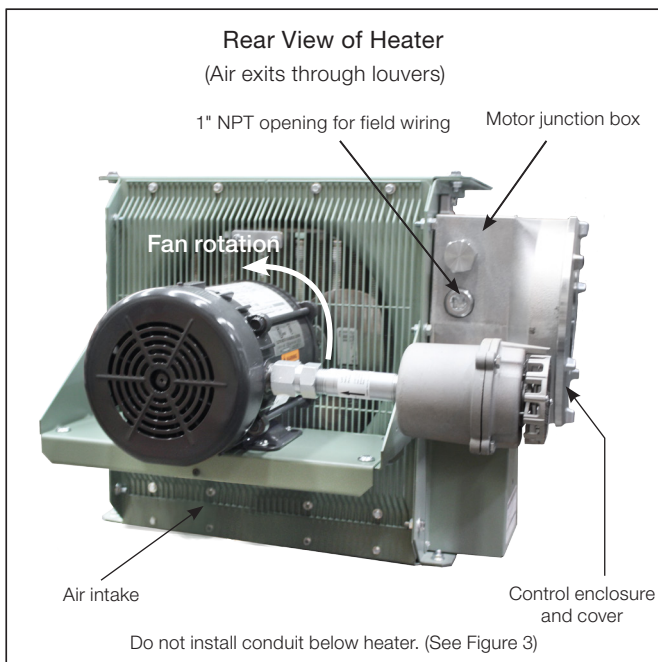

Figure 6

- 2.2 Heater may be supplied with a factory installed built-in room thermostat (see Figure 8, page 10). On heaters not supplied with this option, it is recommended that a remote room thermostat be used. Connect the remote room thermostat conductors to the printed circuit board terminal block marked "TSTAT". Any thermostat used with this heater must:
 - Be of an explosion-proof type
 - Be rated 125V minimum
 - Have a minimum 2 amp capacity
 - Open on temperature rise
- 2.3 Heater may be supplied with a factory installed built-in integral disconnect. (See Figure 8, page 10)

Field Wiring for Integral Disconnect:

- Power Supply conductors and Ground conductor pass through 1" NPT opening of Disconnect Enclosure (see Figure 8, page 10). Supply conductors to be wired to Disconnect Switch inside. Ground conductor to be wired to Ground Lug fastened to inside of Disconnect Enclosure.
 - If applicable, Remote Room Thermostat conductors pass through 1" NPT opening (see Figure 8, page 10) and are to be wired to printed circuit board terminals marked "T'STAT".
 - To reduce risk of ignition of hazardous atmospheres, conduit runs must have a sealing fitting connected within 18" (457 mm).
- 2.4 Factory installed conduits require no further sealing. Integral Disconnect is sealed at factory.
 - The internal grounding terminal in the control enclosure (or in the integral disconnect enclosure when this option is provided) shall be used as the equipment grounding means. An external bonding terminal is provided for a supplementary bonding connection where local authorities permit or require such a connection.

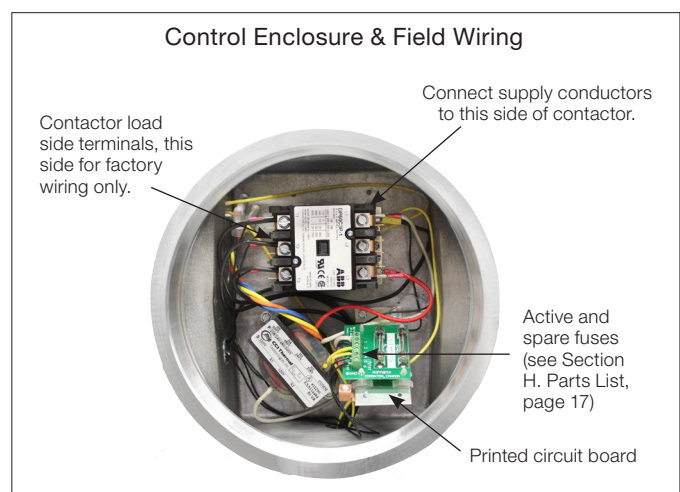

Figure 7

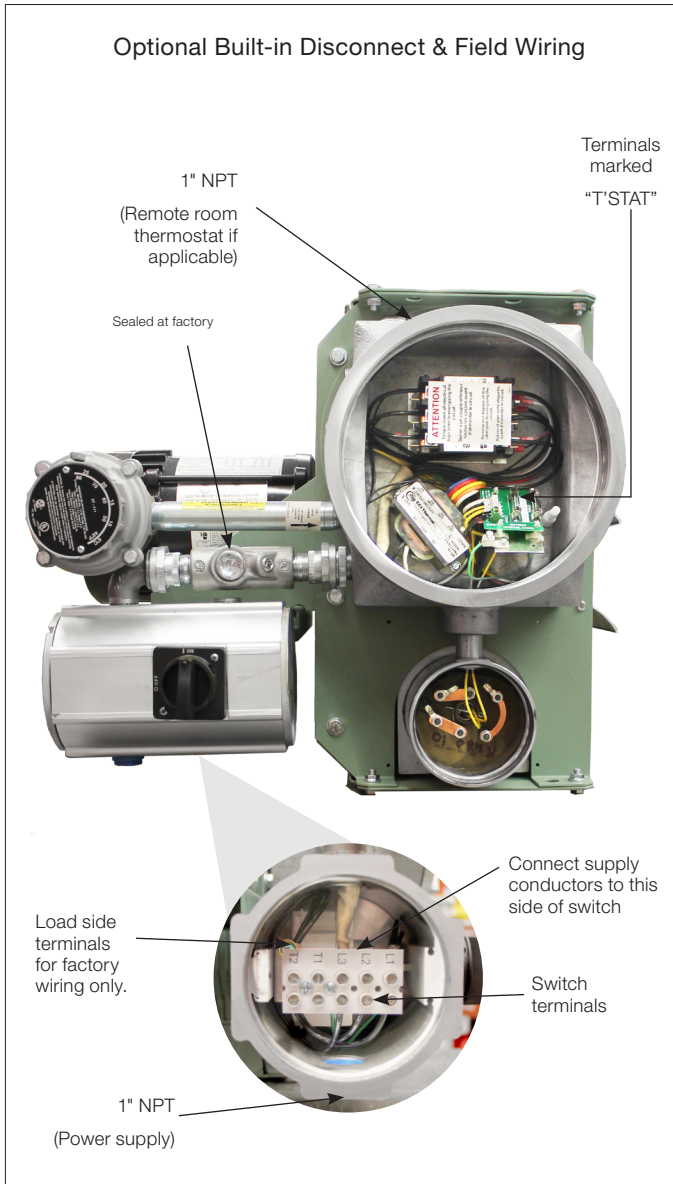

Figure 8

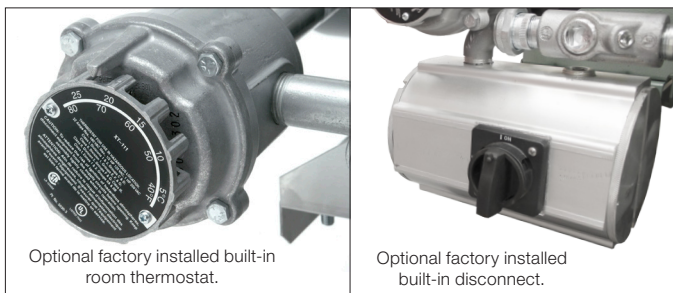

Figure 9

3. Final Inspection

3.1 Before application of electrical power:

- Check that all connections are secured and comply with the applicable wiring diagram (see Wiring Schematics, page 11) and code requirements.
- Confirm that the power supply is compatible with the data plate rating of the heater.
- Remove any foreign objects from the heater.
- Install all covers and verify that all enclosures are well secured.
- Ensure that the fan rotates freely. See Figure 6, page 9 for proper direction of fan rotation.

D.3 Wiring Schematics

1-Phase

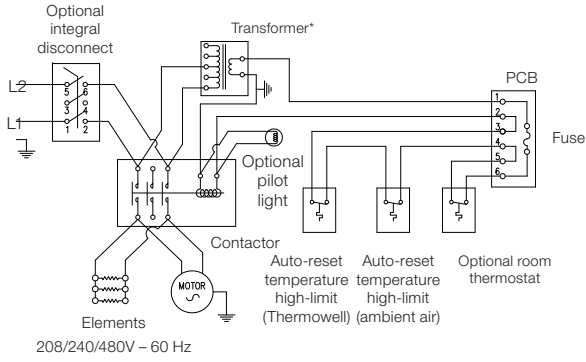

1-Phase with Optional Pilot Light and 3-Way Switch

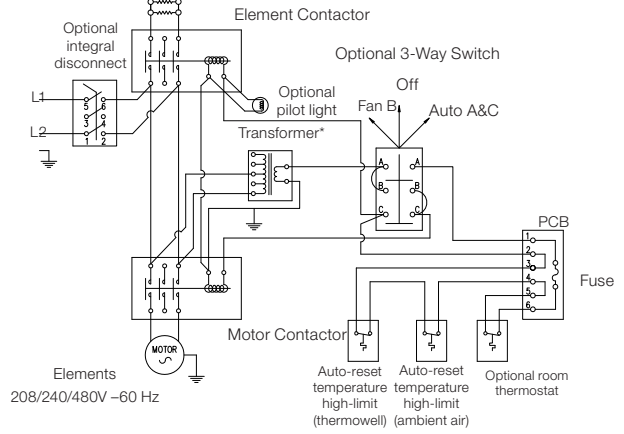

3-Phase

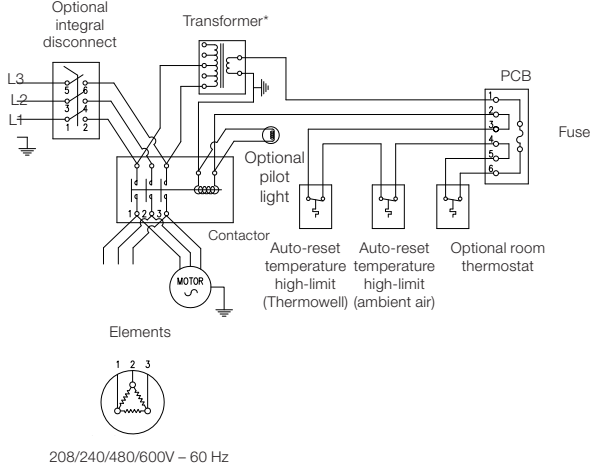

3-Phase 3-Way Switch

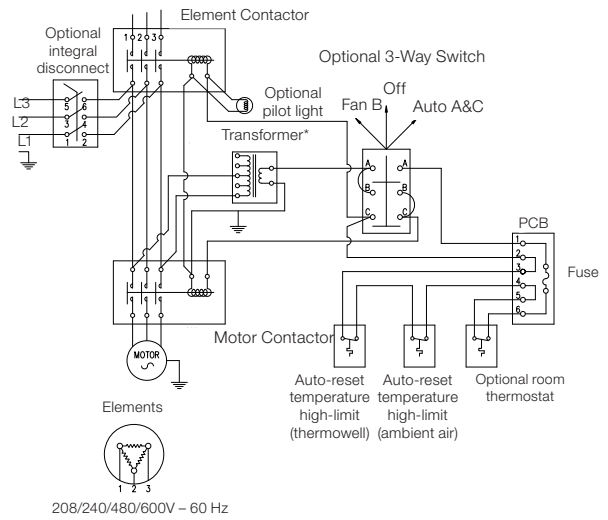

3-Phase Continuous Fan Option

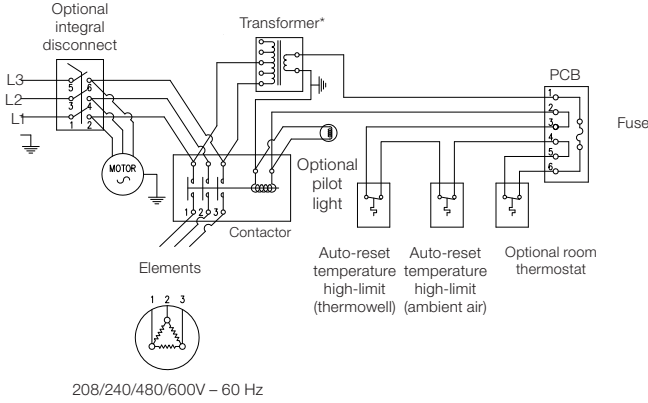

3-Phase 3-Way Switch and Continuous Fan Option

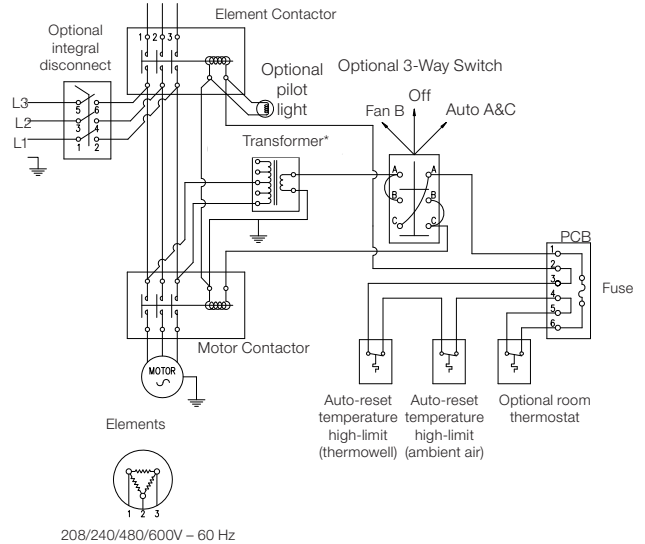

Note: *Primary must match heater voltage

E. HEX5 TECHNICAL DATA

E.1 60 Hz Electric Heaters

Model	Voltage	Nominal Wattage	Phase	Max. Motor Nameplate Current	Heater Wattage	Total Current	Minimum Circuit Ampacity	Supply Wire	Maximum Fuse Size	Temperature Rise		Core Kit Part Number	Contactor Part Number
	V	kW			W	A	A	AWG	A	°F	°C		
HEX5-208160-030	208	3.0	1	4.1	2700	18.5	23.2	10	25	19.0	10.5	12116	3619
HEX5-208160-050		5.0		4.1	4700	28.1	35.2	8	40	31.6	17.6	12117	
HEX5-208160-075		7.5		4.1	7200	40.2	50.2	6	60	27.9	15.5	12118	
HEX5-208160-100*		10.0		4.1	9690	52.2	65.2	6	70	37.2	20.7	12119	
HEX5-208360-030		3	3.0	2.3	2700	10.6	13.3	14	15	11.2	6.2	12116	
HEX5-208360-050			5.0	2.3	4700	16.2	20.2	10	25	18.6	10.3	12117	
HEX5-208360-075			7.5	2.3	7200	23.1	28.9	10	30	27.9	15.5	12118	
HEX5-208360-100			10.0	2.3	9700	30.1	37.6	8	40	37.2	20.7	12119	
HEX5-208360-150	15		2.3	14400	44.0	55.0	6	60	27.1	15.1	12120		
HEX5-240160-030	240		3.0	1	4.1	2700	16.6	20.8	10	25	19.0	10.5	
HEX5-240160-050		5.0	4.1		4700	24.9	31.2	8	35	31.6	17.6	12123	
HEX5-240160-075		7.5	4.1		7200	35.4	44.2	8	45	27.9	15.5	12124	
HEX5-240160-100		10.0	4.1		9700	45.8	57.2	6	60	37.2	20.7	12125	
HEX5-240160-150*		15.0	4.1		14400	66.6	83.3	4	90	27.1	15.1	12126	
HEX5-240360-030		3	3.0	2.4	2700	9.6	12.0	14	15	19.0	10.5	12122	
HEX5-240360-050			5.0	2.4	4700	14.4	18.1	12	20	31.6	17.6	12123	
HEX5-240360-075			7.5	2.4	7200	20.5	25.6	10	30	27.9	15.5	12124	
HEX5-240360-100			10.0	2.4	9700	26.5	33.1	8	35	37.2	20.7	12125	
HEX5-240360-150			15.0	2.4	14400	38.5	48.2	8	50	27.1	15.1	12126	

Notes

- * Exceeds the 48 amp circuit limit of NEC 424-22. DS5 not available for these units.
- **480V: 1-phase units are certified for Class I, Div. 1, Group D and Class II, Div. 1 Groups F & G
- 1. Minimum conductor size for 86°F (30°C) ambient. Derate conductor for ambient temperature. Use minimum 194°F (90°C) insulation.
- 2. Heater is functioning normally if at rated voltage the amp draw is within 10% of the value in this table.
- 3. Operation at lower voltages will result in reduced heat output and amp draw.
- 4. Add "T" to model number when adding a built-in thermostat.
- 5. Add "D" to model number when adding a built-in disconnect switch.

Model	Voltage	Nominal Wattage	Phase	Max. Motor Nameplate Current	Heater Wattage	Total Current	Minimum Circuit Ampacity	Supply Wire	Maximum Fuse Size	Temperature Rise		Core Kit Part Number	Contactor Part Number	
	V	kW			W	A	A	AWG	A	°F	°C			
HEX5-480160-030 **	480	3.0	1	0.8	2700	7.1	8.8	14	10	19.0	10.5	12129	3619	
HEX5-480160-050 **		5.0		0.8	4700	11.2	14.0	14	15	31.6	17.6	12130		
HEX5-480160-075 **		7.5		0.8	7200	16.4	20.5	10	25	27.9	15.5	12131		
HEX5-480160-100 **		10.0		0.8	9700	21.6	27.0	10	30	37.2	20.7	12132		
HEX5-480160-150 **		15.0		0.8	14400	32.1	40.1	8	45	27.1	15.1	12133		
HEX5-480160-200 **		20.0		0.8	19400	42.5	53.1	6	60	36.1	20.1	12134		
HEX5-480360-030		480	3.0	3	1.2	2700	4.8	6.0	14	10	19.0	10.5		12129
HEX5-480360-050			5.0		1.2	4700	7.2	9.0	14	10	31.6	17.6		12130
HEX5-480360-075			7.5		1.2	7200	10.2	12.8	14	15	27.9	15.5		12131
HEX5-480360-100			10.0		1.2	9700	13.2	16.6	12	20	37.2	20.7		12132
HEX5-480360-150			15.0		1.2	14400	19.3	24.1	10	25	27.1	15.1		12133
HEX5-480360-200			20.0		1.2	19400	25.3	31.6	8	35	36.1	20.1		12134
HEX5-480360-250			25.0		1.2	24200	31.3	39.1	8	40	22.0	12.2		12135
HEX5-480360-300			30.0		1.2	29200	37.3	46.7	8	50	26.4	14.6		12136
HEX5-480360-350		35.0	1.2	34200	43.3	54.2	6	60	30.7	17.1	12137			
HEX5-600360-030		600	3.0	3	0.7	2700	3.6	4.5	14	10	19.0	10.5		12138
HEX5-600360-050	5.0		0.7		4700	5.5	6.9	14	10	31.6	17.6	12139		
HEX5-600360-075	7.5		0.7		7200	7.9	9.9	14	15	27.9	15.5	12140		
HEX5-600360-100	10.0		0.7		9700	10.3	12.9	14	15	18.1	20.7	12141		
HEX5-600360-150	15.0		0.7		14400	15.2	18.9	12	20	27.1	15.1	12142		
HEX5-600360-200	20.0		0.7		19400	20.0	25.0	10	30	36.1	20.1	12143		
HEX5-600360-250	25.0		0.7		24200	24.8	31.0	8	35	45.2	25.1	12144		
HEX5-600360-300	30.0		0.7		29200	29.6	37.0	8	40	26.4	14.6	12145		
HEX5-600360-350	35.0	0.7	34200	34.4	43.0	8	45	30.7	17.1	12146				

- | | |
|--|---|
| 6. Add "P" to model number when adding a built-in pilot light. | 10. Add "A" to model number for units with stainless steel cabinet. |
| 7. Add "S" to model number when adding a 3-way switch. | 11. Add "L" to model number for units with pilot and 3-way switch or large box option. |
| 8. Add "H" to model number for units with high "off" (deenergized) ambient temperatures. | 12. Add "B" to model number for units with low ambient option (down to -58°F or -50°C). |
| 9. Add "U" to model number for units with continuous fan option. | |

F. SPECIFICATIONS



F.1 60 Hz Models

		Nominal kW								
		3	5	7.5	10	15	20	25	30	35
Maximum Altitude	ft	12,000	8,000	10,000	7,000	10,000	7,000	10,000	7,000	6,000
	m	3,658	2,438	3,048	2,134	3,048	2,134	3,048	2,134	1,829
Air Flow	@ 70°F (CFM)	500		850		1750		3600		
	@ 21°C (m ³ /hr)	850		1444		2973		6116		
Horizontal Air Throw	ft	15		30		40		70		
	m	4.6		9.1		12.2		21.3		
Maximum Mounting Height (to underside)	ft	7		10				20		
	m	2.1		3.0				6.1		
Minimum Motor Power	HP	1/2								
	kW	0.373								
Fan Diameter	in	12			16			20		
	mm	305			406			508		
Net Weight	without DS5	lbs	148		177		212			
		kg	67.1		80.2		96.2			
	with DS5	lbs	160		189		224			
		kg	82.5		95.6		101.6			
Shipping Weight	without DS5	lbs	202		227		263			
		kg	91.6		103.9		119.3			
	with DS5	lbs	214		239		275			
		kg	97		108.3		124.7			

Note:

*Some units may be Class I, Div. I, Group D and Class II, Div. 1, Group F & G.

Specifications for 60 Hz Models

1. Hazardous Location Rating	Class I, Groups C and D; Class II, Groups E, F and G; Temperature Code T3B [329°F (165°C)]*
2. Enclosures	NEMA Type 7 & 9. For dry, indoor use only. Do not immerse in water. Do not store or use in areas exposed to rain or snow
3. Motor Type	Explosion-proof. Thermally protected. Permanently lubricated ball bearings. 1725 RPM
4. Fan	Aluminum blade. Steel spider and hub with 5/8" (15.875 mm) bore
5. Fan Guard	Split design with close wire spacing. 1/4" (6.3 mm) diameter probe will not enter
6. Mounting Holes	Two 9/16". (14.3 mm) diameter holes at top
7. Heating Elements	Three long-life, low watt-density, high grade metal-sheathed elements
8. Temperature High-Limit	Automatic reset type, snap-action bimetal, open on temperature rise. Rated 100,000 cycles at 10 amps, handles 0.128 amps
9. Control Circuit	120V, 0.128 amps, 15 VA. (Grounded)
10. Slim Junction Box	10.25" (230 mm) x 8.00" (180 mm) x 6.75" (172 mm)
11. Optional Built-in Thermostat	Explosion-proof. 36°F to 82°F (2°C to 28°C)
12. Optional Built-in Disconnect Switch	DS5 for use only on heaters with total current not exceeding 48 amps. Lockout handle accepts 1/4" diameter padlock shackle
13. Optional Three Way Switch	Fan only, Off, Auto
14. Optional Pilot Light	Indicates heat-on cycle
15. Control Transformer	Multi-tap primary, 120V secondary, 50 VA
16. Contactor	75 amps. Rated for 1,000,000 mechanical operations. 120V, 15 VA coil (separately fuse-protected)
17. Heat Transfer Fluid	Long life formulated propylene glycol and water
18. Cabinet Material	12 ga. (0.104") (2.60 mm) steel. Epoxy coated with five-stage pretreatment, including iron phosphate. Optional stainless steel.
19. Core	Steel with integral aluminum fins, vacuum charged and hermetically sealed
20. Conduit Material	Heavy walled, 0.122" (3.1 mm) steel
21. Overpressure Protection	Preset 100 psig (690 kPa) pressure relief valve, aluminum body, no field serviceable parts
22. Operational Temperature Limitations	-4°F to 104°F (-20°C to 40°C); for "B" units -58°F to 104°F (-50°C to 40°C)
23. Storage Limitations	-49°F to 176°F (-45°C to 80°C), short term to 248°F (120°C). Do not immerse in water. Do not expose to rain or snow.

G. PARTS ASSEMBLY DIAGRAM

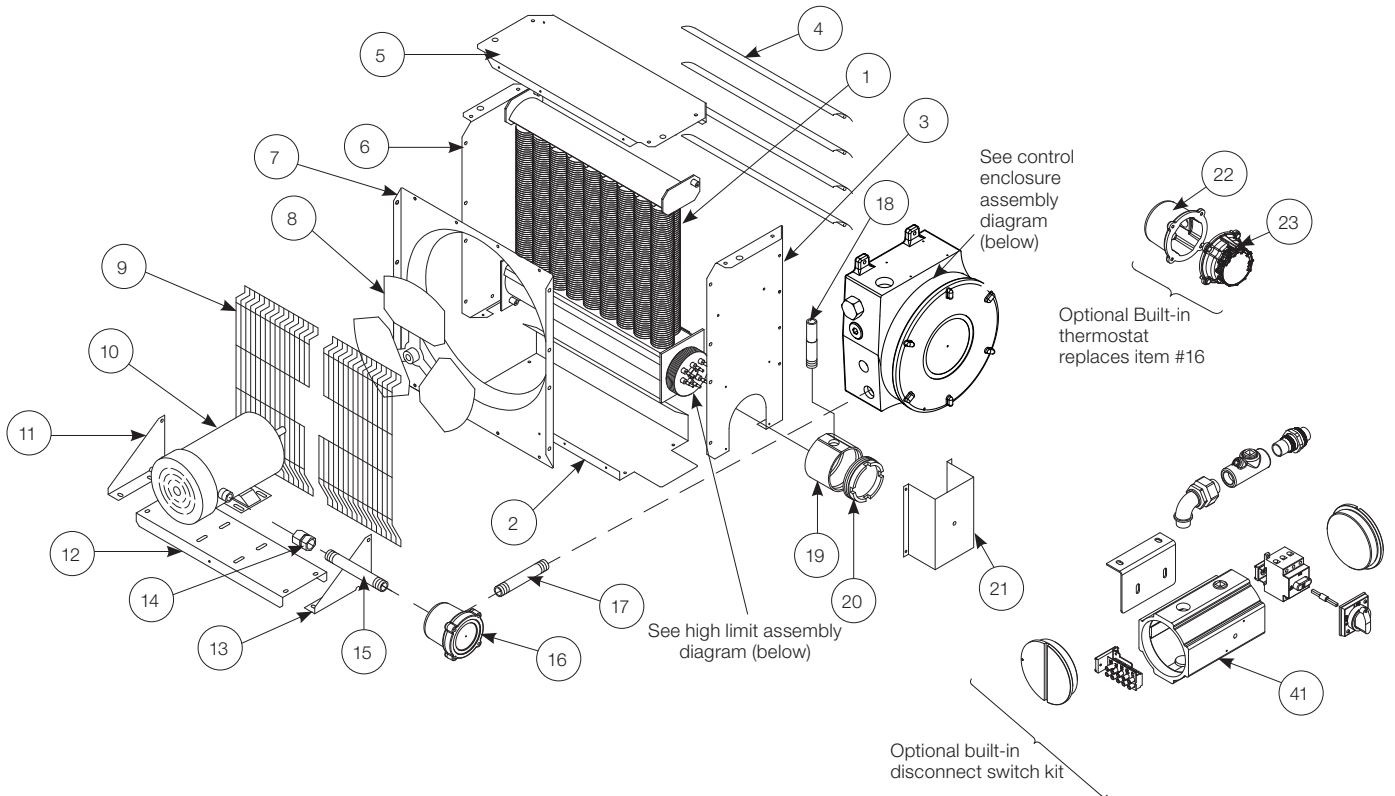

Slim Control Enclosure

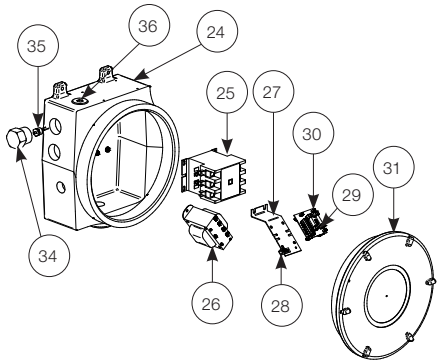

Large Control Enclosure

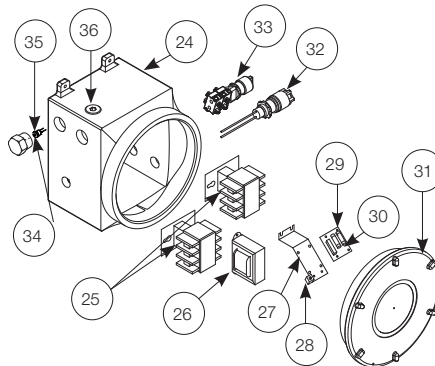

High Limit

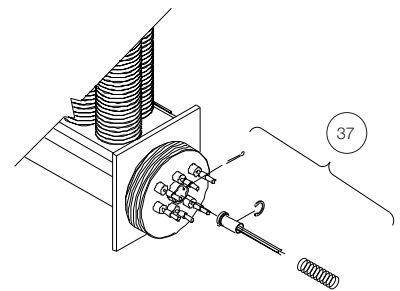

Bus-Bar Configuration for all 1-Phase Models

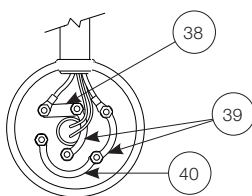

Bus-Bar Configuration for all 3-Phase

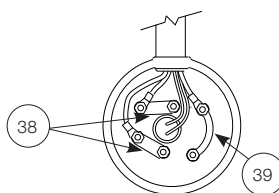

H. PARTS LIST Forced Air Electric Heaters

Please have model and serial number available before calling

Item	Description	2.5 – 4.6 kW	6.3 – 10 kW	12.5 – 20 kW	20.9 – 35 kW
1	Core	**			
2	Panel, Bottom	Painted: 12694-02 S.S.: 12694-03		Painted: 12699-02 S.S.: 12699-03	Painted: 12704-02 S.S.: 12704-03
3	Panel, Left Side	Painted: 12691-02 S.S.: 12691-03		Painted: 12696-02 S.S.: 12696-03	Painted: 12701-02 S.S.: 12701-03
4	Louver Kit, c/w screws	4075		4076	4077
5	Panel, Top	Painted: 12693-02 S.S.: 12693-03		Painted: 12698-02 S.S.: 12698-03	Painted: 12703-02 S.S.: 12703-03
6	Panel, Right	Painted: 12692-02 S.S.: 12692-03		Painted: 12697-02 S.S.: 12697-03	Painted: 12702-02 S.S.: 12702-03
7	Panel, Fan Shroud	Painted: 3782 S.S.: 9212		Painted: 3783 S.S.: 9213	Painted: 3784 S.S.: 9214
8	Fan Blade	4022	4023	4024	4025
9	Fan Guard Kit	Painted: 4078 S.S.: 9504		Painted: 4079 S.S.: 9505	Painted: 4080 S.S.: 9506
10	208/240V 1PH 60 Hz	1979 (US Motors)		10388 (Marathon)	
	480V 1PH 60 Hz	9896 (Baldor)		N/A	
	208/240/480V 3PH 60 Hz	1699 (US Motors)		10387 (Marathon)	
	600V 3PH 60 Hz	2433 (US Motors)		10672 (Marathon)	
11	Bracket, Motor Mount Right	Painted: 3789 S.S.: 9112		Painted: 3789 S.S.: 9112	Painted: 3789 S.S.: 9112
12	Channel, Motor Mount	Painted: 3785 S.S.: 9206		Painted: 3786 S.S.: 9207	Painted: 3787 S.S.: 9208
13	Bracket, Motor Mount Left	Painted: 3788 S.S.: 9111		Painted: 3788 S.S.: 9111	Painted: 3788 S.S.: 9111
14	Coupling, Motor	3737 (US Motors) 4590 (Baldor & Marathon Motors)			
15	Conduit, Motor	9500		3813	10389
16	Cover, Thermostat Enclosure	5371			
17	Conduit, Control Enclosure	3813			
18	Conduit, Element Enclosure	9314		9315	9316
19	Enclosure, Element	9679			
20	Cover, Element Enclosure	3510			
21	Panel, Element Enclosure Guard	Painted: 12695-02 S.S.: 12695-03		Painted: 12700-02 S.S.: 12700-03	Painted: 12705-02 S.S.: 12705-03
22	Enclosure, Thermostat	4983			
23	Thermostat, Built-in kit	-			
24	Enclosure, Control	-			
25	Contactors	3619			
26	Transformer	12290 (60 Hz)			
27	Bracket, Printed Circuit Board	3809			
28	Terminal, 6-14 Ga. Screw Lug	1876			
29	Fuse, Buss MDQ - 1/2 Amp	9357			
30	Assembly, Printed Circuit Board	3514			
31	Cover, Control Enclosure	11960			
32	Bulb, Pilot Light	9279			
33	Switch, Explosion-Proof 3-Way	13150			
34	Thermowell, Ambient High-Limit	9267			
35	High Limit, Ambient Temperature	-			
36	Plug, 1" NPT Explosion Proof	12169			
37	Temperature High-Limit Kit	-			
38	Bus-Bar, Straight	Provided with Core Kits**			
39	Bus-Bar, Small Curved				
40	Bus-Bar, Large Curved				
41	Kit, DS5 Assembly	-			

** See technical data table for part numbers. **Note:** For Items not shown, contact factory.

I. REPAIR & REPLACEMENT

WARNING

Disconnect heater from power supply at integral disconnect or fuse box before opening enclosures or servicing heater.

IF INTEGRAL DISCONNECT IS BEING SERVICED, verify that power has been disconnected at fuse box or main panel.

Lock the switch in the “OFF” (open) position and/or tag the switch to prevent unexpected power application.

This heater should only be serviced by personnel with heating and hazardous location equipment experience.

1. After repairing any component:
 - 1.1 Check that electrical connections are correct and secure (see Figure 9, page 10).
 - 1.2 Remove any foreign material from enclosures
 - 1.3 Install and secure all covers
 - 1.4 Ensure that all fasteners are tight
 - 1.5 Remove all foreign objects from heater
 - 1.6 Ensure air exits through louvers and fan rotates counterclockwise when viewed from rear of heater (see Figure 14, page 19).

The heater core is vacuum charged and not field repairable.

2. Core

For core removal:

- 2.1 Remove cabinet bottom and element enclosure cover.
- 2.2 Disconnect all wires entering element enclosure (see Figure 10, page 18).
- 2.3 Slightly loosen all cabinet bolts shown in Figure 10, page 18, to prevent the core from binding.
- 2.4 With an assistant supporting the weight of the core, remove the 3 core mounting bolts. Carefully lower the core out of the cabinet (see Figure 11, page 18).
- 2.5 To return core to factory, use crate supplied with exchange core to protect the element terminals and plate threads.
- 2.6 To reinstall, lift the core up into cabinet while an assistant guides the element wires into the element enclosure conduit.
- 2.7 Position the core and tighten the 3 core mounting bolts. Tighten the remaining cabinet bolts.

3. Temperature High Limit

- 3.1 Remove temperature high-limit assembly and clean the inside of the thermowell (see Figure 12, page 18). A clean thermowell will ensure good thermal contact.
- 3.2 Use only a factory supplied temperature high-limit to ensure safe operation. (Refer to the instructions that accompany the replacement Temperature High Limit Kit).
- 3.3 Reinstall the temperature high-limit assembly with the snap ring and spring into the thermowell without damaging the insulating tube. Secure in place with the cotter pin (see Figure 13, page 18).



Figure 11



Figure 12



Figure 13

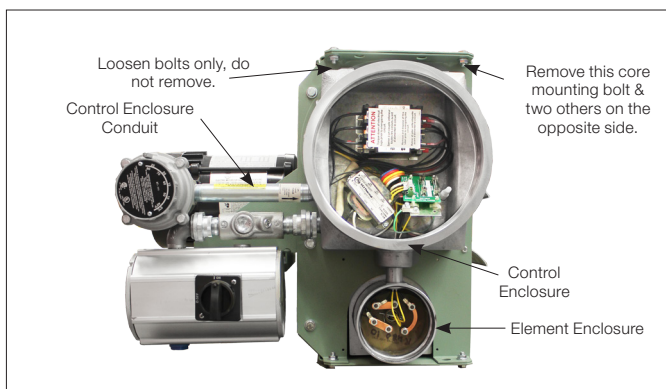

Figure 10

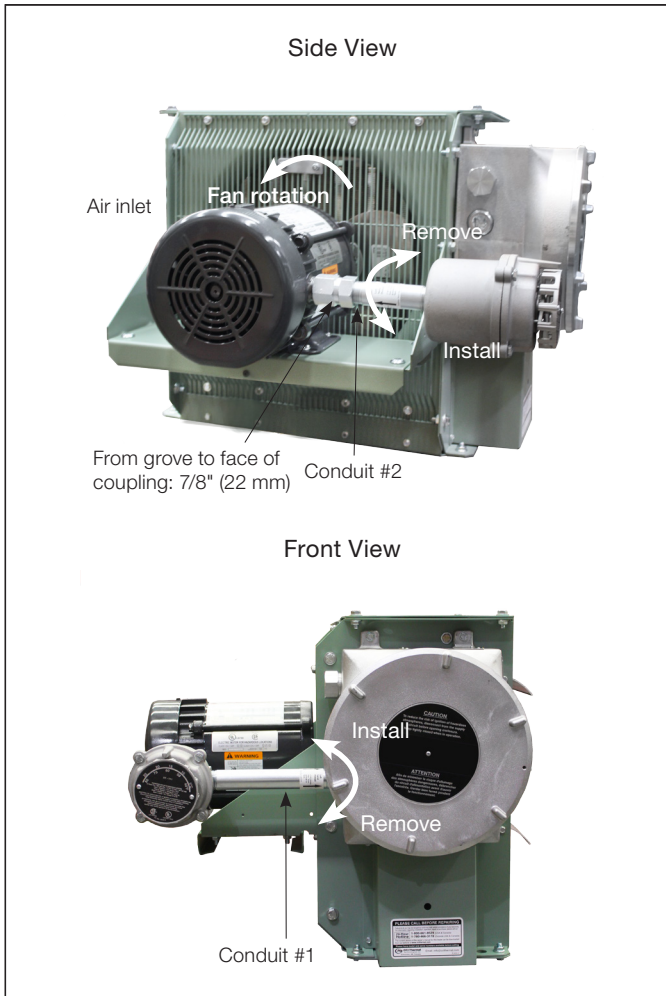

Figure 14



Figure 15



Figure 16

4. Motor, Fan, & Fan Guard
 - 4.1 Remove bolts holding the motor to the motor mount. On units with a built-in thermostat, remove the bolts on the back of the thermostat enclosure.
 - 4.2 Remove conduit #1 located between motor junction box and control enclosure by turning it in the direction illustrated (see Figure 14, page 19). Note that conduits #1 and #2 are not interchangeable and have left hand threads on one end, this end is indicated by a machined groove.
 - 4.3 Remove the two-piece fan guard assembly (see Figure 15, page 19).
 - 4.4 Lift the motor assembly off the motor mount.
 - 4.5 Before removing the fan, measure and record the location of the fan hub on the motor shaft (see Figure 16, page 19). If difficult to remove, use a gear puller on the fan hub.
 - 4.6 To reassemble, place motor assembly onto motor mount and fasten the fan guard to cabinet.
 - 4.7 Simultaneously engage and tighten both ends of conduit #1 into enclosures. Leave a 1/16" to 3/16" (1.6 to 4.8 mm) gap between the motor and fan guard (see Figure 17, page 20). Adjust conduit #2 to center the fan in the shroud.
 - 4.8 To ensure a minimum 5 thread engagement, threaded ends of conduits must protrude a minimum of 1/16" (1.6 mm) into enclosures. The groove on conduit #2 must not be more than 7/8" (22 mm) from motor coupling (see Figure 14, page 19).
 - 4.9 Bolt motor to motor mount. Manually spin the fan blade to ensure fan rotates freely.
 - 4.10 Air must exit through louvers and fan must rotate counterclockwise when viewed from rear of heater (see Figure 14, page 19).
5. Heating Elements
 - 5.1 Heating elements are an integral part of the vacuum charged core. A factory exchange core can be shipped immediately from stock. Refer to 2. Core, page 18 for details.
6. Contactor
 - 6.1 Loosen, but do not remove contactor mounting screws. Slide contactor off mounting screws.
 - 6.2 Replace with a factory supplied contactor of the same rating.
7. Transformer
 - 7.1 Replace with a factory supplied transformer of the same rating.
 - 7.2 On the new transformer, select primary wires to match heater voltage.
 - 7.3 Ensure that the correct transformer secondary lead is grounded (see Figure 9, page 10). Individually terminate all unused wires using closed end connectors.

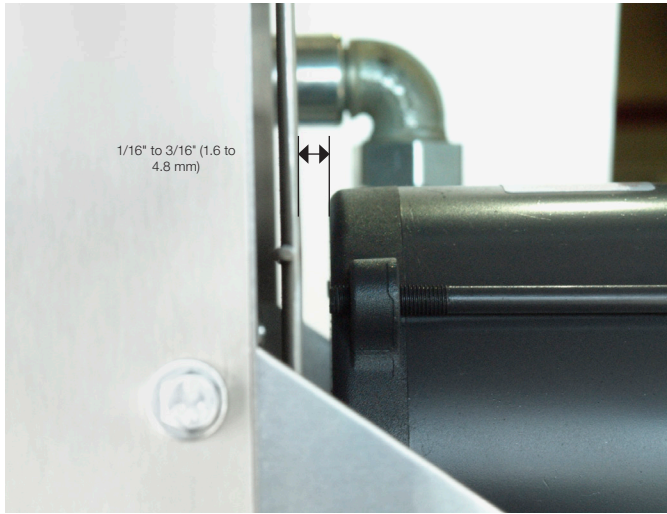

Figure 17

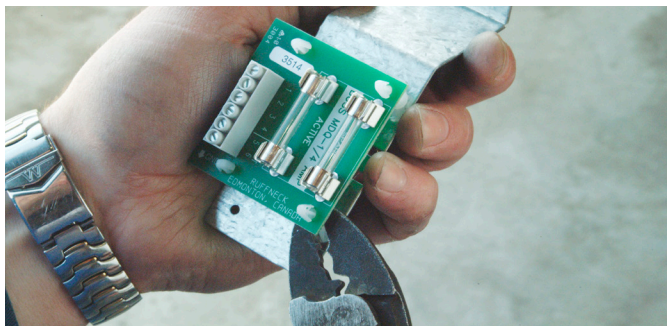
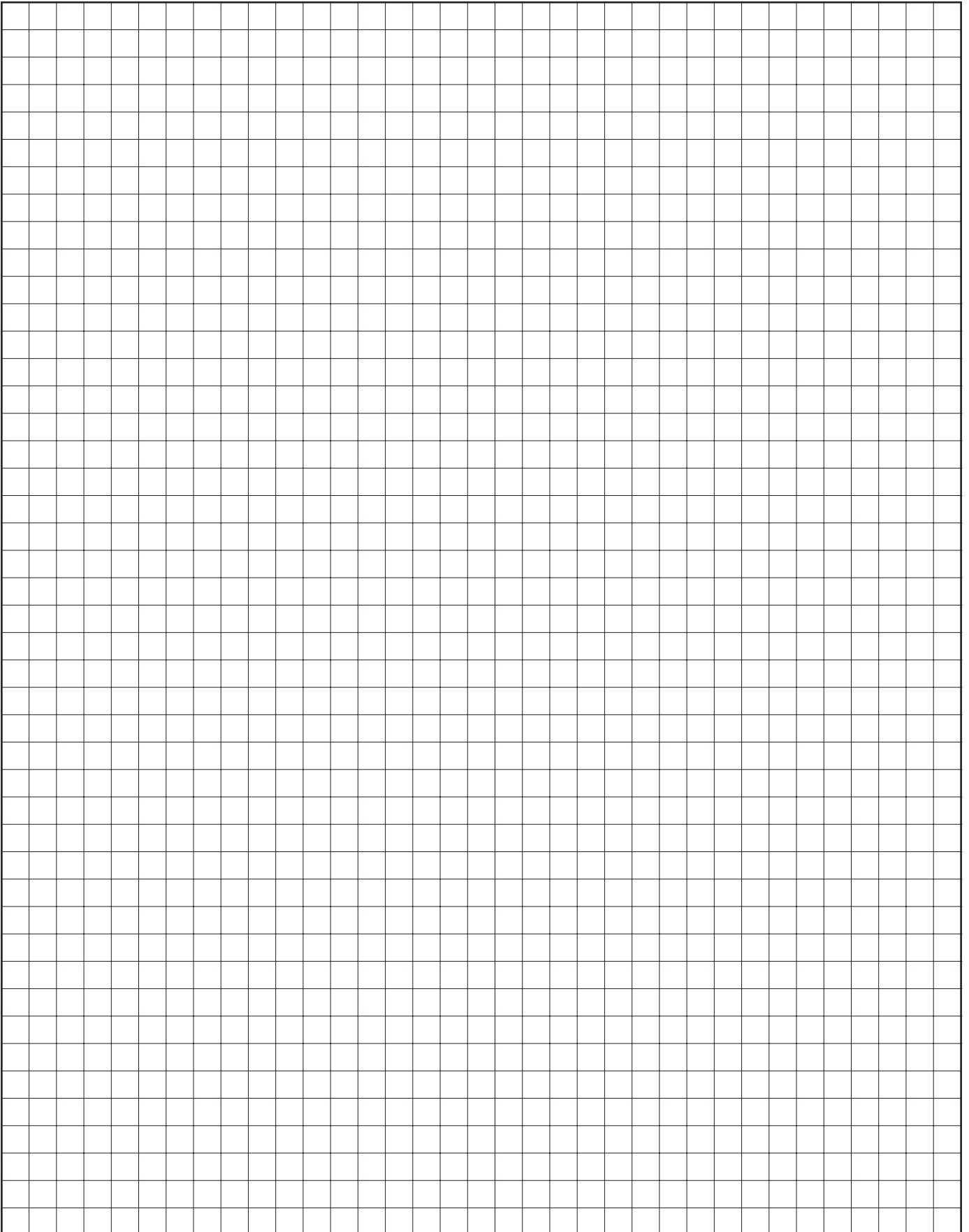

Figure 18

8. Printed Circuit Board
 - 8.1 After removing the printed circuit board (P.C. Board) bracket assembly from the control enclosure, separate the P.C. Board from the bracket by cutting off the plastic spacers (see Figure 9, page 10).
 - 8.2 Reinstall a new factory supplied P.C. Board onto the mounting bracket, using new non-conducting spacers of the same length. Spacers are supplied with a new P.C. Board. Reinstall the control circuit ground wire to the printed circuit board bracket (see Figure 18, page 20).
9. Fuse
 - 9.1 Replace fuse with one of the same type and rating as indicated on P.C. Board or refer to parts list. An extra fuse should be stored in the clips marked "SPARE".
10. Cabinet panels
 - 10.1 Bolt-on cabinet panels are individually replaceable.

NOTES



NOTES

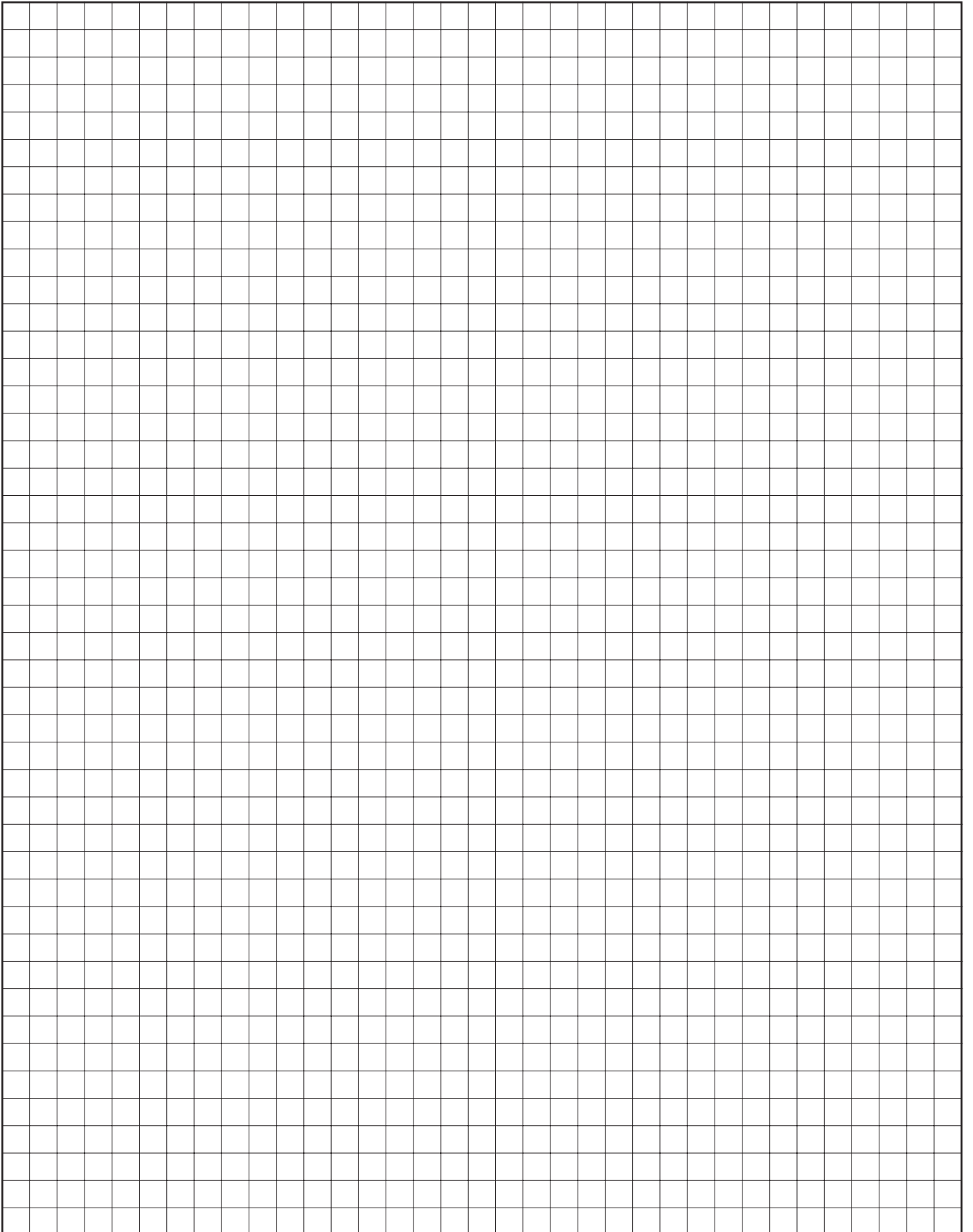

NOTES

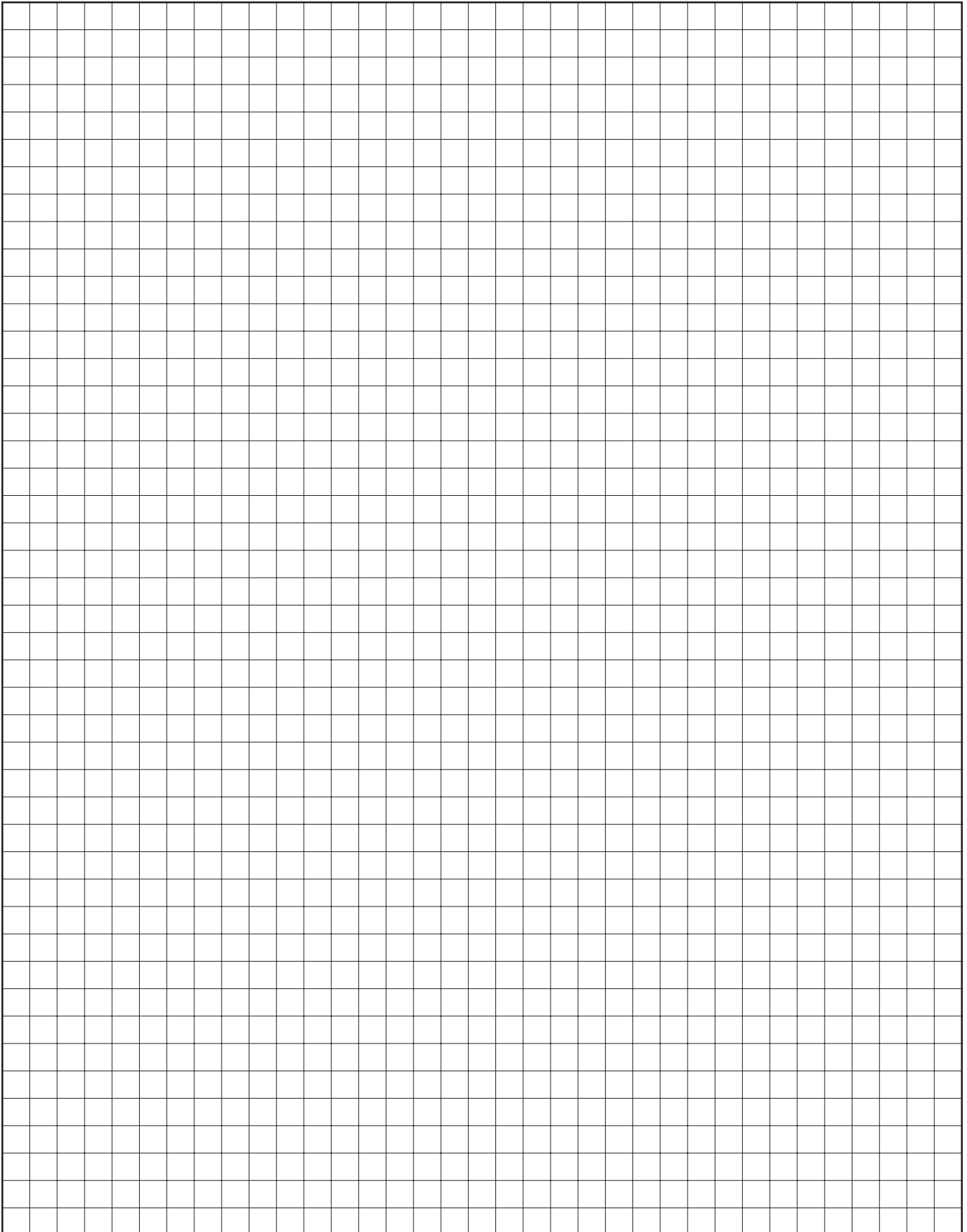

COMMERCIAL WARRANTY

Seller warrants its products to be free from defects in material and workmanship, EXCLUSIVE, HOWEVER, of failures attributable to the use of materials substituted under emergency conditions for materials normally employed. This warranty covers replacement of any parts furnished from the factory of Seller, but does not cover labor of any kind and materials not furnished by Seller, or any charges for any such labor or materials, whether such labor, materials or charges thereon are due to replacement of parts, adjustments, repairs, or any other work done. This warranty does not apply to any equipment which shall have been repaired or altered outside the factory of Seller in any way so as, in the judgment of Seller, to affect its stability, nor which has been subjected to misuse, negligence, or operating conditions in excess of those for which such equipment was designed. This warranty does not cover the effects of physical or chemical properties of water or steam or other liquids or gases used in the equipment.

BUYER AGREES THAT SELLER'S WARRANTY OF ITS PRODUCTS TO BE FREE FROM DEFECT IN MATERIAL AND WORKMANSHIP, AS LIMITED HEREIN, SHALL BE IN LIEU OF AND EXCLUSIVE OF ALL OTHER WARRANTIES, EITHER EXPRESS OR IMPLIED, WHETHER ARISING FROM LAW, COURSE OF DEALING, USAGE OF TRADE, OR OTHERWISE, THERE ARE NO OTHER WARRANTIES, INCLUDING WARRANTY OF MERCHANTABILITY OR FITNESS FOR PURPOSE, WHICH EXTEND BEYOND THE PRODUCT DESCRIPTION CONFIRMED BY BUYER AND SELLER AS OF THE DATE OF FINAL AGREEMENT.

This warranty is void if the input to the product exceeds the rated input as indicated on the product serial plate by more than 5% on gas-fired and oil-fired units, or if the product in the judgment of SELLER has been installed in a corrosive atmosphere, or subjected to corrosive fluids or gases, been subjected to misuse, negligence, accident, excessive thermal shock, excessive humidity, physical damage, impact, abrasion, unauthorized alterations, or operation contrary to SELLER'S printed instructions, or if the serial number has been altered, defaced or removed.

BUYER'S REMEDY FOR BREACH OF WARRANTY, EXCLUSIVE OF ALL OTHER REMEDIES PROVIDED BY LAW, IS LIMITED TO REPAIR OR REPLACEMENT AT THE FACTORY OF SELLER, ANY COMPONENT WHICH

SHALL, WITHIN THE APPLICABLE WARRANTY PERIOD DEFINED HEREIN AND UPON PRIOR WRITTEN APPROVAL, BE RETURNED TO SELLER WITH TRANSPORTATION CHARGES PREPAID AND WHICH THE EXAMINATION OF SELLER SHALL DISCLOSE TO HAVE BEEN DEFECTIVE; EXCEPT THAT WHEN THE PRODUCT IS TO BE USED BY BUYER AS A COMPONENT PART OF EQUIPMENT MANUFACTURED BY BUYER, BUYER'S REMEDY FOR BREACH, AS LIMITED HEREIN, SHALL BE LIMITED TO ONE YEAR FROM DATE OF SHIPMENT FROM SELLER. FOR GAS-FIRED PRODUCTS INSTALLED IN HIGH HUMIDITY APPLICATIONS AND UTILIZING STAINLESS STEEL HEAT EXCHANGERS, BUYER'S REMEDY FOR BREACH, AS LIMITED HEREIN, SHALL BE LIMITED TO TEN YEARS FROM DATE OF SHIPMENT FROM SELLER.

These warranties are issued only to the original owner-user and cannot be transferred or assigned. No provision is made in these warranties for any labor allowance or field labor participation. Seller will not honor any expenses incurred in its behalf with regard to repairs to any of Seller's products. No credit shall be issued for any defective part returned without proper written authorization (including, but not limited to, model number, serial number, date of failure, etc.) and freight prepaid.

OPTIONAL SUPPLEMENTAL WARRANTY

Provided a supplemental warranty has been purchased, Seller extends the warranty herein for an additional four (4) years on certain compressors. Provided a supplemental warranty has been purchased, Seller extends the warranty herein for an additional four (4) years or nine (9) years on certain heat exchangers.

EXCLUSION OF CONSUMABLES & CONDITIONS BEYOND SELLER'S CONTROL

The above referenced warranty shall not be applicable to any of the following items: refrigerant gas, belts, filters, fuses and other items consumed or worn out by normal wear and tear or conditions beyond Seller's control, including (without limitation as to generality) polluted or contaminated or foreign matter contained in the air or water utilized for heat exchanger (condenser) cooling or if the failure of the part is caused by improper air or water supply, or improper or incorrect sizing of power supply.

Component Applicable Models	"APPLICABLE WARRANTY PERIOD"
Heat Exchangers Gas-Fired Unit Heaters	TEN YEARS FROM DATE OF FIRST BENEFICIAL USE BY BUYER OR ANY OTHER USER, WITHIN TEN YEARS FROM DATE OF RESALE BY BUYER OR ANY OTHER USER, WITHIN TEN YEARS FROM DATE OF RESALE BY BUYER IN ANY UNCHANGED CONDITION, OR WITHIN ONE HUNDRED TWENTY-SIX MONTHS FROM DATE OF SHIPMENT FROM SELLER, WHICHEVER OCCURS FIRST
Heat Exchangers Low Intensity Infrared Units Compressors Condensing Units for Cassettes	FIVE YEARS FROM DATE OF FIRST BENEFICIAL USE BY BUYER OR ANY OTHER USER, WITHIN FIVE YEARS FROM DATE OF RESALE BY BUYER OR ANY OTHER USER, WITHIN FIVE YEARS FROM DATE OF RESALE BY BUYER IN ANY UNCHANGED CONDITION, OR WITHIN SIXTY-SIX MONTHS FROM DATE OF SHIPMENT FROM SELLER, WHICHEVER OCCURS FIRST
Burners Low Intensity Infrared Units Other Components excluding Heat Exchangers, Coils, Condensers, Burners, Sheet Metal	TWO YEARS FROM DATE OF FIRST BENEFICIAL USE BY BUYER OR ANY OTHER USER, WITHIN TWO YEARS FROM DATE OF RESALE BY BUYER IN ANY UNCHANGED CONDITION, OR WITHIN THIRTY MONTHS FROM DATE OF SHIPMENT FROM SELLER, WHICHEVER OCCURS FIRST
Heat Exchangers/Coils Indoor and Outdoor Duct Furnaces and System Units, PSH/BSH, Steam/Hot Water Units, Oil-Fired Units, Electric Units, Cassettes, Vertical Unit Ventilators Compressors Vertical Unit Ventilators Burners High Intensity Infrared Units Sheet Metal Parts All Products	ONE YEAR FROM DATE OF FIRST BENEFICIAL USE BY BUYER OR ANY OTHER USER, WITHIN ONE YEAR FROM DATE OF RESALE BY BUYER IN ANY UNCHANGED CONDITION, OR WITHIN EIGHTEEN MONTHS FROM DATE OF SHIPMENT FROM SELLER, WHICHEVER OCCURS FIRST

As Modine Manufacturing Company has a continuous product improvement program, it reserves the right to change design and specifications without notice.



Commercial Products Group
 Modine Manufacturing Company
 1500 DeKoven Avenue
 Racine, WI 53403
 Phone: 1.800.828.4328 (HEAT)
 www.modine.com
 Litho in USA