



Installation Instructions

1548-40RGE End Seal Kit

TOOLS REQUIRED:

Diagonal cutters; needle-nose pliers; utility knife; heat gun or propane torch

KIT CONTENTS:

- (5) - Black heat-shrink tubes $\frac{1}{2}$ " x $1\frac{1}{2}$ "
- (5) - Black heat-shrink tubes $\frac{3}{4}$ " x 4"

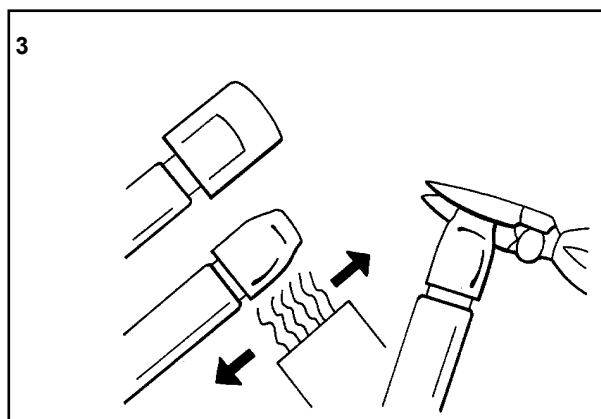
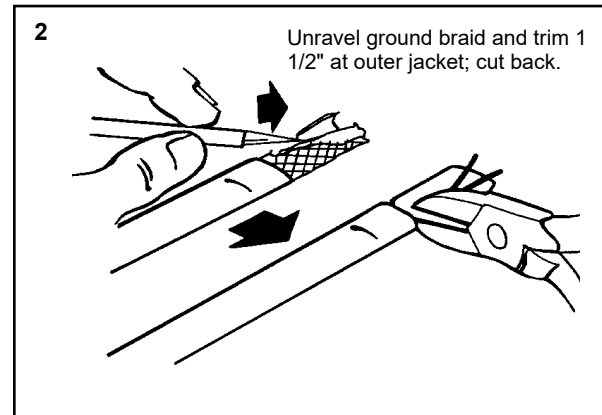
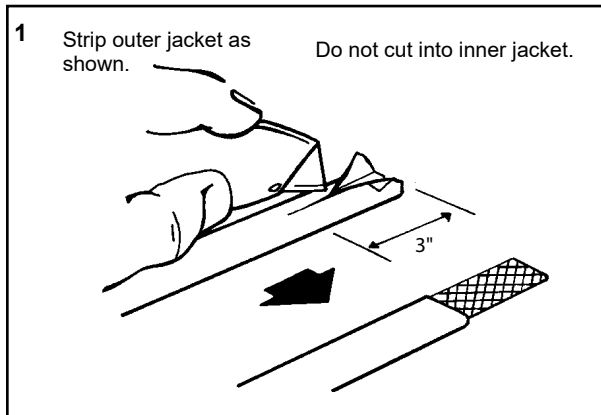
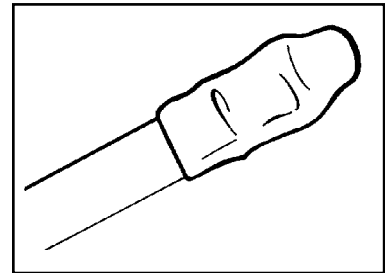

Heat-shrink $1\frac{1}{2}$ " heat-shrink tube in place with $\frac{3}{8}$ " over end of heating cable. Remove heat. Squeeze end with needle-nose pliers. Hold for 10 to 15 seconds.

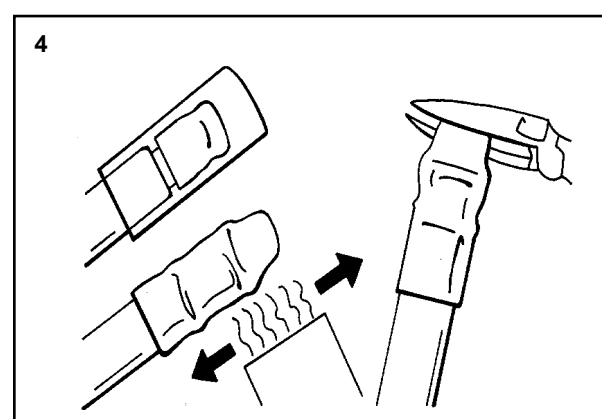

Heat-shrink $\frac{3}{4}$ " x 4" heat-shrink tube in place with $\frac{3}{8}$ " over end of smaller heat-shrink tube. Remove heat, resqueeze at end of smaller heat-shrink tube, then squeeze at end of outer heat-shrink tube. Hold for 10 to 15 seconds.