

# Baseboard Heater K Series



**Model Code:**

4	K	24	10	-BW
A	B	C	D	E

**A: Length**  
**B: Series**  
**C: Volts**  
**D: Watts (375 to 2400)**  
**E: Color (-BW) Bright White (-A) almond**  
**F: -HAL**



- Aluminum Ribbon Fin Element
- Full Length Safety Cutout
- Crushproof Element
- Natural Convection Heat
- Back wire design
- Built-in clamps coming soon
- Baked enamel finish
- Dent resistant die form cover
- 120, 208, 240 or 277 volts
- Standard color: bright white (optional almond color)
- 1-year limited warranty



## The K Series Baseboard Heater

**Baseboard heaters** are an economical way to provide heat. They are typically used in apartment construction and other rental properties because of low initial cost and maintenance. Quality components guarantee a long-lasting, reliable heater. Standard color is bright white. Almond color available. Institutional grade 18 gauge front covers and 22 gauge back cans are available for special applications. All other specifications are the same as the standard heater.

### Dimensional Data

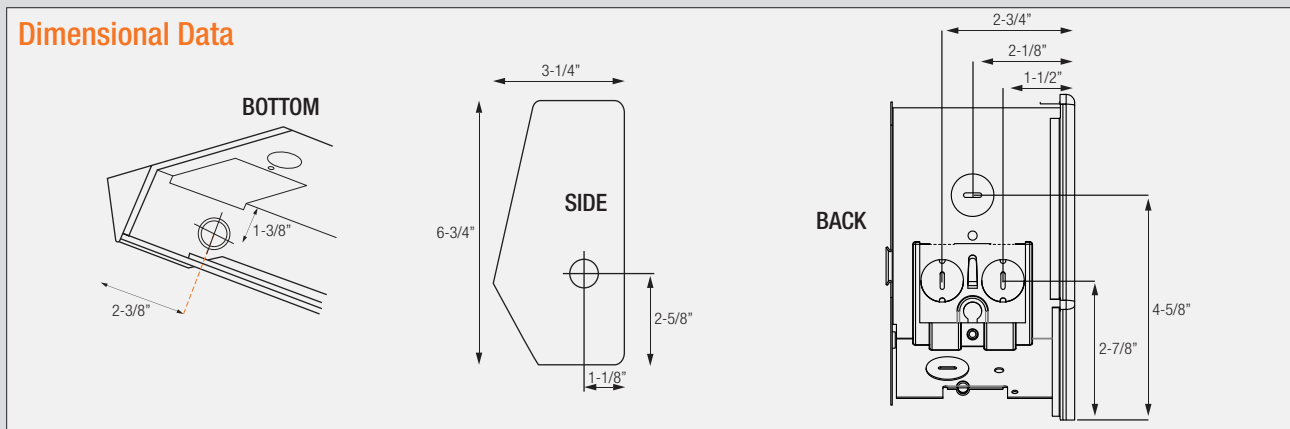

## Engineering Specifications

*Contractor shall supply and install K Series electric convection baseboard heaters manufactured by King Electrical Mfg. Company of the wattage, voltage and length indicated on the plans.*

### Construction:

- The heater shall take room air in the bottom (lower front) and discharge it through the top front.
- The heater back, bottom, and top shall be fabricated from electro-galvanized 22 gauge steel. Front panels shall be fabricated from 22 gauge electro-galvanized steel, ribbed longitudinally for extra strength and have center support to resist impact loads.
- The heater casing shall have modern rounded ends and corners to provide a smooth appearance, finished with a baked enamel.
- The heater shall be provided with a continuous capillary sensor tube for thermal protection, extending the full length of the heating element, rated at 175° F, and be a fail-safe type.

- The heater shall have a 44 cubic inch junction box at both ends, furnished with five 1/2" knockouts located on the back, bottom, and side.
- Heater elements shall consist of high quality 80% Nickel and 20% Chromium alloy corrosion-resistant wire completely surrounded by Magnesium Oxide and enclosed in a rust-resistant sheath. Ribbon aluminum finning shall be compression welded to the sheathed element to provide chimney-type flue for heat transfer.
- Heaters shall be supplied with a one year limited warranty.

### Rating and Approval:

- The heaters shall be available in ratings from 375 through 1,500 Watts at 120 Volts, and 375 to 2,400 Watts at 208-240 and 277 Volts.
- The heaters shall be available in 187 or 250 Watts per lineal foot.
- cULus (E29778)

# Baseboard Heater K Series

**Ordering Information** Standard models Add suffix -A for optional almond color. Add suffix -HAL for high altitude

	MODEL	UPC	VOLTS	WATTS	AMPS	LENGTH	SHIP WEIGHT lbs
<b>120V</b>	2K1205BW	11362	120	500	4.2	27"	6.5
	3K1207BW	11366	120	750	6.3	3 ft.	8
	4K1210BW	11370	120	1000	8.3	4 ft.	10.5
	5K1212BW	11374	120	1250	10.4	5 ft.	13
	6K1215BW	11378	120	1500	12.5	6 ft.	15
<b>208V</b>	2K2005BW	11382	208	500	2.4	27"	6.5
	3K2007BW	11386	208	750	3.6	3 ft.	8
	4K2010BW	11390	208	1000	4.8	4 ft.	10.5
	5K2012BW	11394	208	1250	6.0	5 ft.	13
	6K2015BW	11398	208	1500	7.2	6 ft.	15
<b>240V</b>	8K2020BW	11402	208	2000	9.6	8 ft.	19
	8K2024BW	11441	208	2400	11.5	8 ft.	19
	2K2405BW	11410	240/208	500/375	2.1/1.8	27"	6.5
	3K2407BW	11414	240/208	750/563	3.1/2.7	3 ft.	8
	4K2410BW	11418	240/208	1000/750	4.2/3.7	4 ft.	10.5
<b>277V</b>	5K2412BW	11422	240/208	1250/938	5.2/4.5	5 ft.	13
	6K2415BW	11426	240/208	1500/1125	6.3/5.5	6 ft.	15
	8K2420BW	11434	240/208	2000/1500	8.3/7.2	8 ft.	19
	8K2424BW	11437	240/208	2400/1800	10.0/8.7	8 ft.	19
	2K2403BW	11442	277	500	1.8	27"	6.5
	3K2405BW	11446	277	750	2.7	3 ft.	8
	4K2407BW	11452	277	1000	3.6	4 ft.	10.5
	5K2410BW	11456	277	1250	4.5	5 ft.	13
	6K2412BW	11460	277	1500	5.4	6 ft.	15
	8K2415BW	11464	277	2000	7.2	8 ft.	19
	8K2418BW	11468	277	2400	9.0	8 ft.	19

**Ordering Information** \*Low Density: 187 Watts per foot Add suffix -A for optional almond color. Add suffix -HAL for high altitude

MODEL	UPC	VOLTS	WATTS	AMPS	LENGTH	SHIP WEIGHT lbs
2K2405BW	11410	208	375	1.8	27"	6.5
3K2407BW	11414	208	563	2.7	3 ft.	8
4K2410BW	11418	208	750	3.6	4 ft.	10.5
5K2412BW	11422	208	938	4.5	5 ft.	13
6K2415BW	11426	208	1125	5.4	6 ft.	15
7K2418BW	11430	208	1313	6.3	7 ft.	19
8K2420BW	11434	208	1500	7.2	8 ft.	19
8K2424BW	11437	208	1800	9.0	8 ft.	19
2K2403BW	11442	240	375	1.6	27"	6.5
3K2405BW	11446	240	563	2.3	3 ft.	8
4K2407BW	11452	240	750	3.1	4 ft.	10.5
5K2410BW	11456	240	938	3.9	5 ft.	13
6K2412BW	11460	240	1125	4.7	6 ft.	15
8K2415BW	11464	240	1500	6.3	8 ft.	19
8K2418BW	11468	240	1800	7.8	8 ft.	19

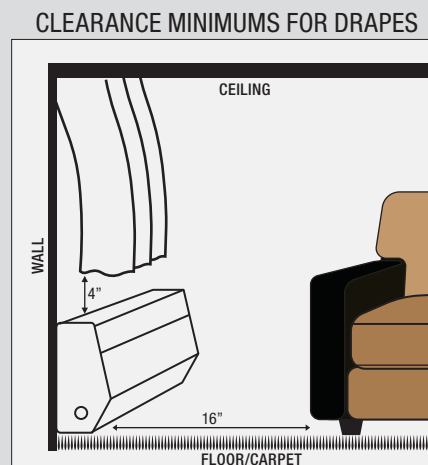
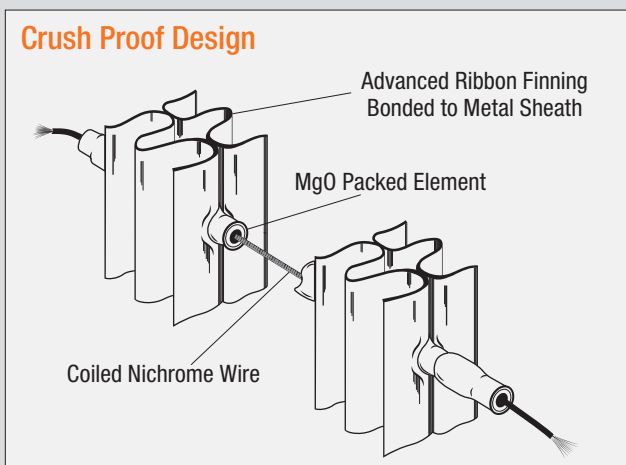

# Baseboard Heater Accessories K & CB Series

## Accessories

MODEL	UPC	DESCRIPTION	WEIGHT lbs
BKC-BW	11474	Corner Connector - Bright White	1.5
BKR120BW	11494	Duplex Cover Plate (includes 120V receptacle) - Bright White (See below)	0.5
BKLT120BW*	11481	Load Transfer Cover Plate (Heat/Cool/Off) 120V - Bright White	0.5
BKLT240BW*	11483	Load Transfer Cover Plate (Heat/Cool/Off) 240V - Bright White	0.5
BKCB1BW	11532	3-3/4" Relay Control Box - Bright White	1.5
BKCB2BW	11534	7-1/8" Dual Relay Control Box - Bright White	3.0
BKT1BW	11484	Built-In Thermostat Kit (SPST) - Bright White (5 Pack)	0.6
BKT1BW-TP	11542	Built-In Tamperproof Stat Kit (SPST) - Bright White (5 Pack)	0.3
BKT2BW	11488	Built-In Thermostat Kit (DPST) - Bright White (5 Pack)	0.5
BKT2BW-TP	11544	Built-In Tamperproof Stat Kit (DPST) - Bright White (5 Pack)	0.6
-HAL	N/A	High Altitude Limit for Baseboards used over 6500 feet	N/A
BKT-TIMER3HR-BW	11487	3 Hour spring wound timer/wire leads 16 amp/250 Vac. 15 Amp/125 Vac.	0.6

\*Requires BKCB1 Control box, order separately.

## Shield Options

\* Specify Color: Almond or White NON Cancel-able - NON Returnable item (NCNR)

MODEL	UPC	DESCRIPTION	WEIGHT lbs
SHIELD-33"	10290	Heater Shield for 27" Baseboard	6
SHIELD-42"	10291	Heater Shield for 3' Baseboard	7
SHIELD-54"	10292	Heater Shield for 4' Baseboard	8.5
SHIELD-66"	10293	Heater Shield for 5' Baseboard	10
SHIELD-78"	10294	Heater Shield for 6' Baseboard	11
SHIELD-102"	10295	Heater Shield for 8' Baseboard	14

## Cover Options

\* Specify Color: Almond or White NON Cancel-able - NON Returnable item (NCNR)

MODEL	UPC	DESCRIPTION	WEIGHT lbs
BB-18ga Cover 2'	52054	18 Gauge Cover for 27" Baseboard	1.5
BB-18ga Cover 3'	52056	18 Gauge Cover for 3' Baseboard	2
BB-18ga Cover 4'	52058	18 Gauge Cover for 4' Baseboard	2.6
BB-18ga Cover 5'	52060	18 Gauge Cover for 5' Baseboard	3.65
BB-18ga Cover 6'	52062	18 Gauge Cover for 6' Baseboard	4
BB-18ga Cover 8'	52064	18 Gauge Cover for 8' Baseboard	5.3

## Thermostats, Options & Accessories

