



TPI CORPORATION
America's Comfort Conditioning Company



**HV SERIES
INDUSTRIAL
HIGH VELOCITY BLOWER**

CUSTOMER		DATE:	
PROJECT			
LOCATION			
ARCHITECT			
ENGINEER			
CONTRACTOR			
SUBMITTED BY			
APPROVED BY			
APPROVED BY			

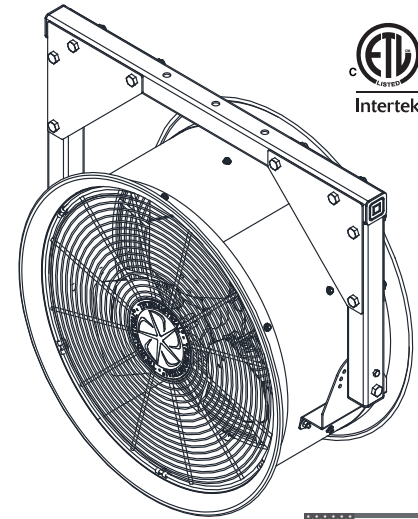

**MADE IN
THE U.S.A.**

SUBMITTAL DATA SHEET

QTY	MODEL	TAG	WATTAGE	VOLTS	PH	AMPS	BRACKET
NOTES/SPECIAL INSTRUCTIONS:							

- Aluminum blade
- OSHA approved spiral, wire front and rear guards
- Wall and ceiling mounting options
- Gray epoxy powder coated 20 ga. steel housing
- 2 year limited warranty
- Stationary
- Direct drive

Standard Models

SIZE	MFG CATALOG NUMBER	MFG MODEL NUMBER	VOLTS	PHASE	HP	WATTS	CFM / RPM	DIMENSIONS				AMPS (High)	WT. (LBS)
								"H"	"W"	"D"	Dia.		
18"	HV18-120V	08195602	120	1	1/2	373	3000 / 1725	25 7/8"	23 3/8"	13 1/2"	20 7/8"	5.0	45
	HV18-208/240V	08195702	208/240									2.6	
	HV18-277V	08195802	277									2.1	
	HV18-480V	08195902	480									1.3	
	HV18-480V-3	08197202	480	1.0*									
24"	HV24-120V	08196002	120	1	1/2	373	5290 / 1725	30 1/4"	33 1/4"	13 1/2"	26 7/8"	5.0	58
	HV24-208/240V	08196102	208/240									2.6	
	HV24-277V	08196202	277									2.1	
	HV24-480V	08196302	480									1.3	
	HV24-480V-3	08197302	480	1.0*									
30"	HV30-120V	08196402	120	1	1	746	9000 / 1700	38 7/8"	38 7/8"	16"	32 7/8"	10.0	85
	HV30-208/240V	08196502	208/240									4.7	
	HV30-277V	08196602	277									3.6	
	HV30-480V	08196702	480									2.1	
	HV30-480V-3	08197402	480	1.7*									

Motor Specifications

- 1-Phase
- Ball bearing motor
- 1/2 or 1 HP
- TEAO
- Single speed
- 373 & 746 watts
- Automatic thermal protection

MOUNTING BRACKETS			
MFG CATALOG NUMBER	MFG MODEL NUMBER	SIZE	WT. (LBS)
08197502	HV-1	18"	14
08197602	HV-2	18" & 24"	22
08197702	HV-3	30"	24

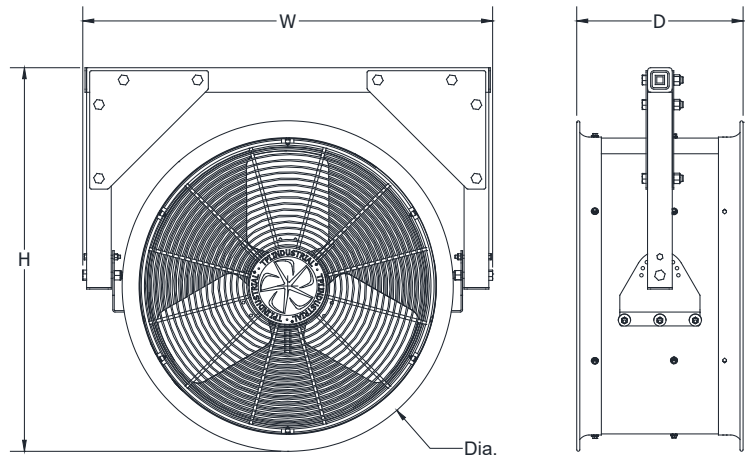

- 11 gauge steel
- Gray epoxy powdercoated housing

