

GVG STANDING SEAM METAL ROOF CLIPS

For Installing Self-Regulating Heat Cable on Standing Seam Metal Roofs

GVG-325 • GVG-50 • GVG-625

INSTALLATION MANUAL

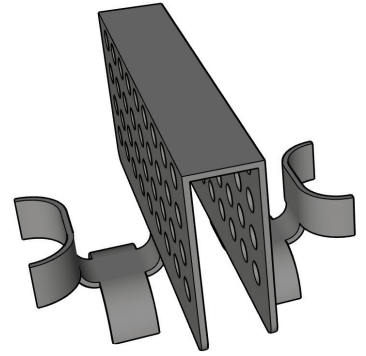

DESCRIPTION

v.10.18.21

The GVG clip comes in three sizes and is designed to provide a strong attachment point for the installation of heat cable on most common standing seam metal roofs. Verify the width of your standing seams to determine which GVG to use before installation. The GVG-325 will fit standing seams between 1/8" to 3/8", the GVG-50 will fit standing seams between 1/4" to 1/2" and the GVG-625 will fit standing seams between 1/2" to 5/8". Keep in mind that some gaps between the GVG clip and the standing seam side or top is acceptable (See details below). The GVG clip requires a seam with a minimum height of 1 1/4".

TOOLS & SUPPLIES

- Screw gun
- Hex head driver bit (5/16")
- Butyl pads (best method for sealing screws)
- Silicone caulk (alternate method for sealing screws)

SYSTEM DESIGN

Always follow the heat cable manufacturer's installation recommendations to determine the cable tracing pattern. The height and width of your heat cable pattern will be dictated by the type of roof system you have and the heat cable manufacturer's installation manual.

CLIP SELECTION

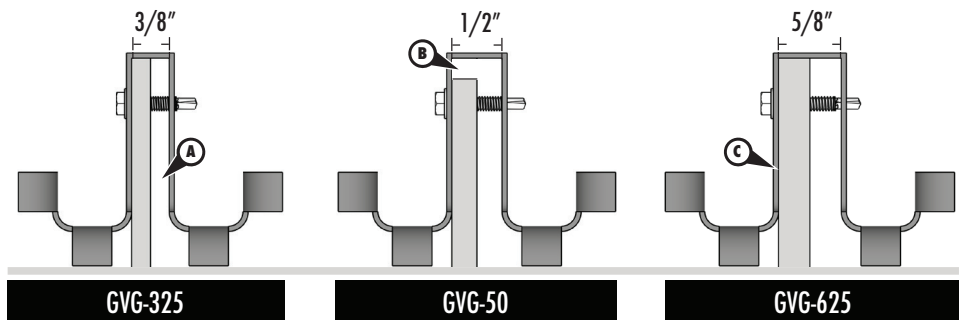

Choose the GVG clip that most closely matches the width of your standing seams. Note that if you plan to use MKS-1022-2 butyl pads, they are 1/8" thick. It is not necessary for both sides of the clip to be in direct contact with both sides of the standing seam. A gap between the side of the clip (A) or the top of the clip (B) and the standing seam is acceptable. As long as the clip is screwed firmly up against one side of the standing seam (C) the clip will have sufficient long-term strength for holding a heat cable system in place. We recommend the use of the MKS-1022-2 butyl pad to provide a weather-proof seal around the screws. You may elect to caulk the screw heads as an alternate.

STANDARD INSTALLATION PATTERN

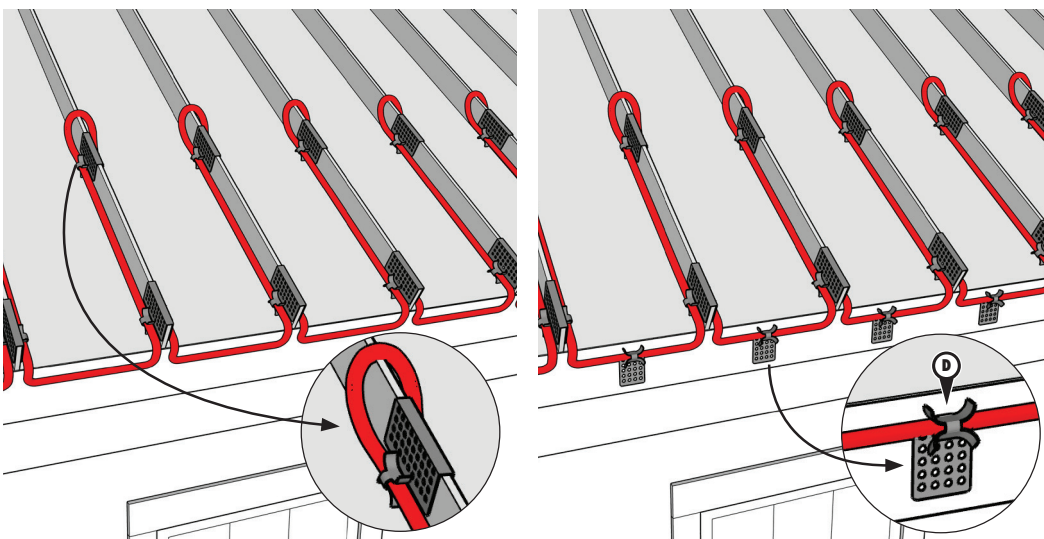

Shown, left, is a common cable pattern that reduces the likelihood of stress on the cable system caused by sliding snow and ice. Cable that traverses the open field of a metal roof will be subjected to forces caused by sliding snow and ice that can damage to the cable and/or the clips. We recommend the use of snow restraint systems to reduce the likelihood of cable system damage on all applications. The lower, horizontal cable areas can be secured to the fascia or inside a gutter with an optional IDP-113 standard roof clip (D) that is screwed or glued in place.

For more information visit www.radiantsolutionscompany.com

GVG HEAT CABLE ROOF CLIP INSTALLATION MANUAL



FASTENER SEALING CONSIDERATIONS

Although GVG clips can be installed directly onto a standing seam, we recommend using an optional MKS-1022-2 butyl pad under each clip for two reasons. First, butyl will seal around the screws and help prevent water ingress into the standing seam over time. Second, the MKS-1022-2 pads were designed specifically to fit the footprint of the GVG series clips to promote the most tenacious bond between the clip and the standing seam. If you choose to install the GVG clip directly onto a standing seam without butyl pads, be certain to at minimum caulk the screw heads with silicone after the clip is installed.

GVG CLIP INSTALLATION

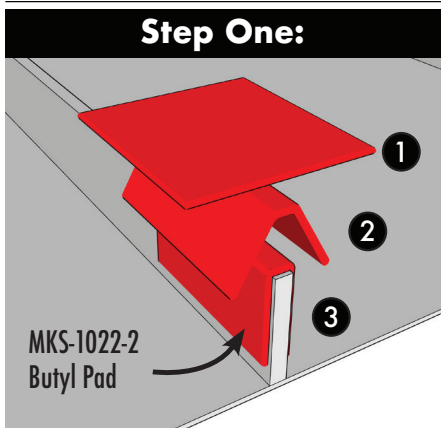

Step One: Peel the backing off both sides of a butyl pad (MKS-1022-2) and fold it over the standing seam at the desired clip location. Clean the area first with a rag and common isopropyl alcohol (rubbing alcohol) to ensure a good bond between the butyl and the metal. For best results, keep the butyl pads warm before installation.

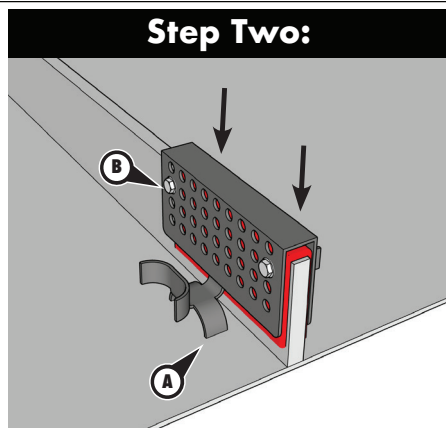

Step Two: Set the clip onto the seam until it either rests on top of the seam OR the cradles are touching the roof (A). Using a drill and a 5/16" hex head driver bit, fasten the clip to the seam using two provided self-tapping sheet metal screws. Install screws near the top of the seam (B) to reduce likelihood of water ingress into the roof system. Do NOT over tighten screws as they will strip the holes.

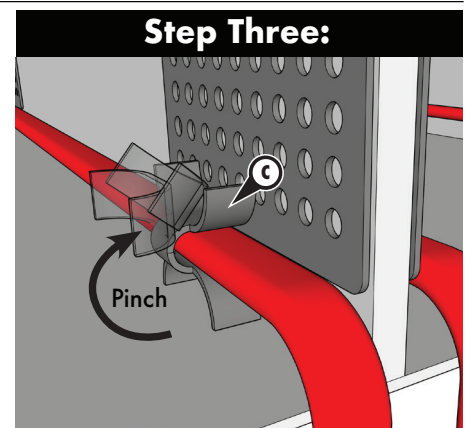

Step Three: After fastening the clip, lay the heat cable into the cradle (C) and use your fingers to pinch the top half of the cradle down onto the cable. A pliers may also be used for the pinching process.

Clip Spacing: We recommend placing clips no more than 36" apart. On tracing patterns greater than 36" use three or more GVG clips should be used on each seam.

ADDITIONAL DETAILS

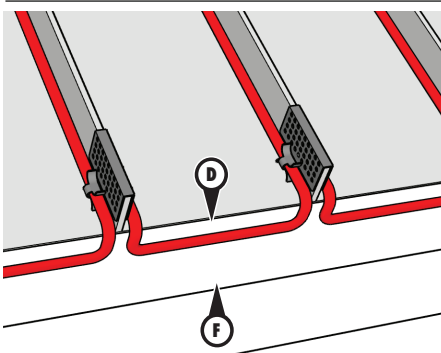

The architectural conditions below the drip line of each metal roof (D) varies greatly. The fascia (F) may be wood or clad in sheet metal. There may be drip edge flashing or a gutter, or both, for example. The treatment of the horizontal cable areas will therefore be different from job to job. Some installers prefer to use a standard IDP-113 roof clip to secure this area as illustrated on page one (D).

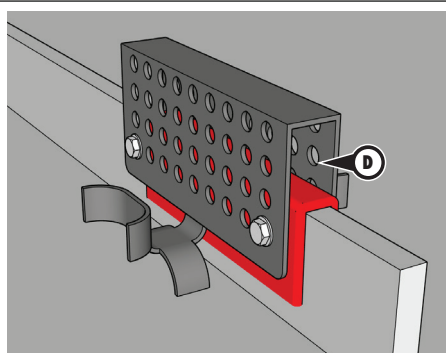

As noted, there may be a gap (D) between the top of the GVG clip and the standing seam. This will not affect the performance of the clip. During installation, the GVG clip should be pushed down until the cradles touch the main surface of the metal roof or the clip sits on top of the seam.

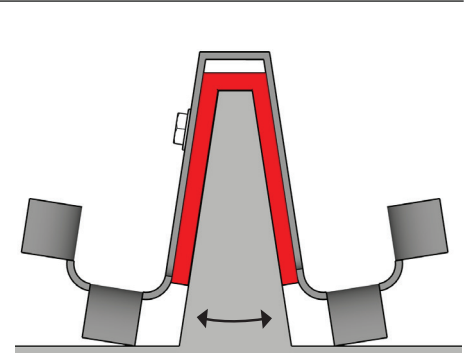

The GVG clip can be modified on site to fit a variety of circumstances. Here, the legs of the clip were spread slightly to accommodate a triangular shaped standing seam.

Note: Always consult with the roofing manufacturer to verify compatibility of the GVG Series clips with their roofing system.

For more information visit www.radiantsolutionscompany.com