

FRIO SMC GATEWAY SETUP GUIDE

The Frio S1 Heat Trace Controller can is capable of BACnet IP and BACnet MS/TP communication via an SMC Gateway (FS-EZ3-MOD-BAC). The Frio S1 features a Modbus RTU Slave Interface to allow communication to the SMC Gateway. Up to 32 S1 controllers can be serially connected to one SMC Gateway. A list of BACnet objects available for each Frio S1 controller is included at the end of this document.

This setup guide provides users with the required information to configure the SMC Gateway to communicate with Frio S1 controllers. To configure the gateway, you will also need project specific information provided on the forms included at the end of this document. For questions, please contact support at info@frio.co

SMC GATEWAY SETUP USING WEB INTERFACE

Please The SMC Startup Guide is available at: <https://msa.webdamdb.com/bp/#/folder/9069681/118191016>

NOTE: MSA acquired SMC and is slowly changing over the branding of SMC devices.

1. CONNECT PC TO THE SMC GATEWAY

The default IP Address for the SMC EZ Gateway is 192.168.2.101, Subnet Mask is 255.255.255.0. If the PC and SMC Gateway are on different IP networks, assign a static IP Address to the PC on the 192.168.1.xxx network. Once the PC network settings have been configured to match the default Gateway subnet, move on to the next step.

2. OPEN YOUR BROWSER TO CONNECT TO THE SMC GATEWAY

Using a browser go to <http://192.168.2.101/login/> and you should see an SMC login page. The first time the Gateway GUI is opened in a browser, the IP Address for the gateway will appear as untrusted. This will cause the pop-up window shown below to appear. When the Web Server Security Unconfigured window appears, read the text and choose whether to move forward with HTTPS or HTTP.

NOTE: Section 6.2 in SMC Gateway Start-up Guide describes HTTPS security options and how to update them.

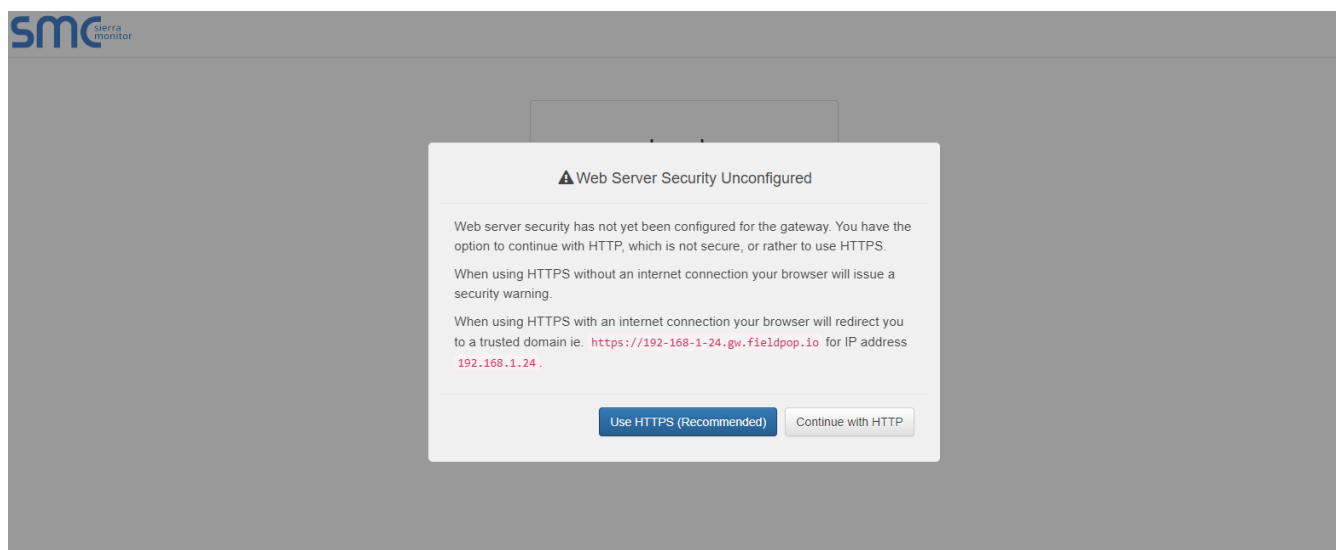

3. PROCEED WITH THE CONNECTION

When the warning that “Your connection is not private” appears, click the advanced button on the bottom left corner of the screen. Additional text will expand below the warning, click the underlined text to go to the IP Address. In the example below this text is “Proceed to 192.168.2.101 (unsafe)”.



Your connection is not private

Attackers might be trying to steal your information from **192.168.2.101** (for example, passwords, messages, or credit cards). [Learn more](#)

NET::ERR_CERT_COMMON_NAME_INVALID

 To get Chrome's highest level of security, [turn on enhanced protection](#)

Hide advanced

Back to safety

This server could not prove that it is **192.168.2.101**; its security certificate is from ***.gw.fieldpop.io**. This may be caused by a misconfiguration or an attacker intercepting your connection.

[Proceed to 192.168.2.101 \(unsafe\)](#)

4. LOGIN AS ADMIN

When the login screen appears, put in the Username (default is “admin”) and the Password (found on the label of the Gateway).

Username = admin

Password = The Default password is located in the SMC Gateway label. An example is shown on the following page.

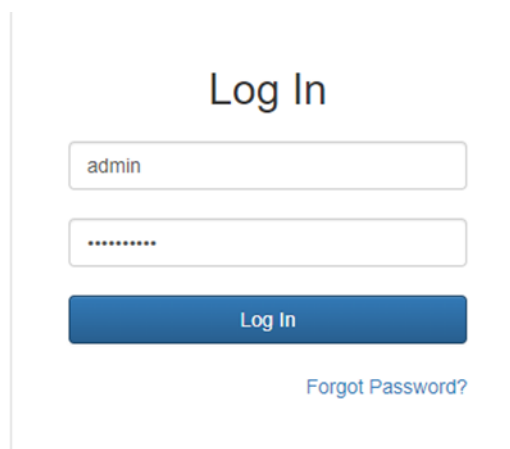

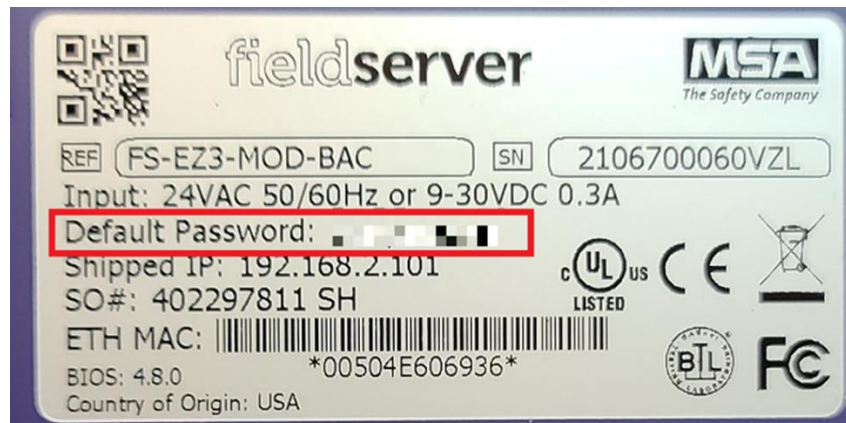

EXAMPLE GATEWAY LABEL

5. SELECT GATEWAY SECURITY MODE

On the first login to the Gateway, the following screen will appear that allows the user to select which mode the Gateway should use. To understand all the security options please read Section 6.2 of SMC Gateway Start-up Guide

Web server security is not configured

Please select the web security profile from the options below.

Note that browsers will issue a security warning when browsing to a HTTPS server with an untrusted self-signed certificate.

Mode

- HTTPS with default trusted TLS certificate (requires internet connection to be trusted)
- HTTPS with own trusted TLS certificate
- HTTP (not secure, vulnerable to man-in-the-middle attacks)

Save

NOTE: Cookies are used for authentication.

NOTE: To change the web server security mode after initial setup, go to Section 11.1 of SMC Gateway Start-up Guide “Change Web Server Security Settings After Initial Setup”.

6. OPEN SMC LANDING PAGE

Once step #5 is complete, the SMC Gateway landing page will appear.

7. CONFIGURE “CONNECTIONS”

Go to “Connections” and fill the form based on the information provided from the client as shown in the next image.

- For all devices select **Modbus RTU R1 Enable** and confirm settings match the image below.
- For BACnet IP devices, select **BACnet IP Enable**
- For BACnet MS/TP select **BACnet MSTP R2 Enable** and enter the configuration information provided by the client.

Press “Save” and “Restart”.

8. IMPORT S1 DEVICE PROFILES

Go to “Device Profiles” press “Import->Choose File” and select the provided Frio S1 configuration file “S1-vx.x.x.profile” and press the “Import” button. The S1 Profile file will be provided by Frio upon request.

Press “Save” and “Restart”.

At this point you should see that a profile called “S1” has been added

9. ADD NEW DEVICE

Go to “DeviceProxy” and add a new “Device” as shown in the next image. The required information should be supplied by the client on the Frio SMC Gateway Configuration Form at the end of this document.

Device Profile	Modbus Connection	BACnet Connection	Modbus Node ID	Modbus Node IP Address	Modbus Node IP Port	BACnet Device Instance	BACnet Device Name	Advanced
1 S1	R1 (Modbus R)	R2 (BACnet M)	1		502	0	MUW-21470009	
2 S1	R1 (Modbus R)	R2 (BACnet M)	2		502	1	MET-21470016	
3 S1	R1 (Modbus R)	R2 (BACnet M)	3		502	2	CWS & EQ EAST	
4 S1	R1 (Modbus R)	R2 (BACnet M)	4		502	3	CWR/S-21470001	

- “Modbus Node ID” is the Modbus RTU address of the Frio S1 Heat Controller, in this example the address = 10
- “BACnet Connection” is the transport medium (BACnet IP or BACnet MSTP) that you want each S1 controller to be associated with.
- “BACnet Device Instance” is a number that identifies a device uniquely on the entire interconnected BACnet network. **No other device anywhere on a BACnet IP network may have the same BACnet instance number.** For BACnet MSTP, each device on a gateway requires a unique number.
- “BACnet Device Name” is a custom name to identify this Frio S1 Controller in this example = “S1-Heat Control”

Repeat Step 9 to add additional Frio S1 controllers. Press “Save” and “Restart” when you are done.

NOTE: Pressing the “Advanced” button will allow to enter “Device Description” and “Device Location”.

10. CONFIGURE IP NETWORK SETTINGS (FOR BACNET IP ONLY)

Go to “Settings->Network” and change the IP network settings according to the information provided by the client.

After changing the network settings press “Save” and “Restart”.

NOTE: You may lose network connectivity if you are in a different subnet that the subnet entered in the setting.

The screenshot shows the SMC (Sierra Monitor Control) web interface. The top left corner features the SMC logo and the text "sierra monitor". The top right corner displays "FieldServer EZ Gateway Modbus to BACnet". On the left side, there is a navigation menu with the following items: Configuration, Gateway, Connections, DeviceProxy™, Device Profiles, Bacnet Explorer, Settings (expanded), Network (highlighted in blue), SMC Cloud™, About, and Logout. The main content area is titled "IP Settings" and contains the following configuration fields:

- N1 DHCP Client State:
- N1 IP Address:
- N1 Netmask:
- Default Gateway:
- Domain Name Server 1:
- Domain Name Server 2:

At the bottom right of the form, there are two buttons: "Save" and "Refresh".

CONNECTING AND TESTING THE FRIO S1 AND THE SMC GATEWAY

1. WIRE THE FRIO S1 AND SMC GATEWAY

Turn off power to both the Frio S1 and the SMC Gateway and wire the devices as shown below:

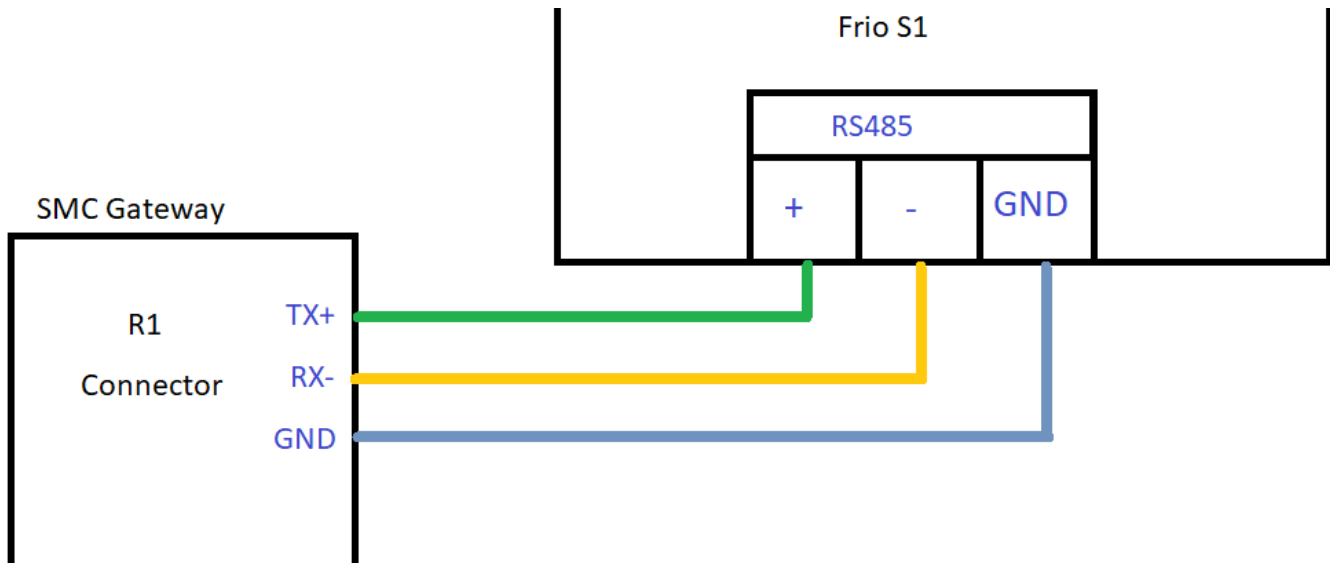

NOTE: Up to 32 Frio S1 Controllers may be connected to each gateway.

2. CONNECT TO THE LOCAL AREA NETWORK (TO TEST BACNET IP)

Connect the SMC Gateway to the LAN using a ethernet RJ45 cable. Power on both devices and using a browser go to “<ip address set>”. You should be presented with the login page for the SMC gateway . Enter the username and password (see step #4) and you should be able to login and verify settings entered in the previous steps.

3. CONNECT GATEWAY TO COMPUTER USING RS485 (TO TEST BACNET MSTP)

Connect the SMC Gateway to your computer using a USB to RS485 adapter.

4. CONFIGURE THE FRIO S1 CONTROLLERS

Using the Frio S1 HMI Menu go to Settings->Advanced Settings->Modbus and set the Modbus parameters as shown in in the BACnet Configuration form for your project. Available Modbus parameters are shown in the table below.

Variable	Description	Default	Range/Options
Enable	Enable or disable the serial port	OFF	Bool
Address	Modbus Station Address used to identify the unit.	1	1 to 247
Baud Rate	Baud Rate - the rate at which communications occur on the network	38400	9600, 19200, 38400, 57600
Parity	Defines the type of parity bit to be used with any of the three serial communications ports.	None	None, Odd, Even
Stop Bits	Defines the number of stop bits used with the serial communications port.	1	1, 2

NOTE: The “Address” value should match the “Modbus Node ID” entered in Step #9.

NOTE: “Enable” must be set to “ON” in order for the S1 to communicate with the SMC Gateway.

At this point a BACnet BMS software application should be able to discover the SMC gateway as a BACnet device and read the BACnet fields/properties.

5. TEST THE BACNET CONFIGURATION

Using a BMS application capable of BACnet communication, test the SMC Gateway and Frio S1 devices. The following image shows a test using the BACnet Quick Test application with a SMC Gateway connected to a Frio S1 Heat Trace Controller. For questions on testing please contact Frio at info@frio.co.

