

FOSTORIA INDUSTRIES, INC.
 1200 North Main Street
 Fostoria, OH 44830
 Phone: 800-495-4525
 Fax: 419-435-0842
 www.fostoriaindustries.com

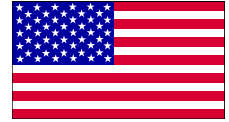

A DIVISION OF



If you have questions about the product you have purchased or would like to leave us feedback please contact us via our website www.fostoriaindustries.com or by calling 1-800-495-4525.



FES - Series
 Portable Electric Heaters



(FES-1524-3E shown)

YES - Series
 Suspended Electric Heaters

	⚠ WARNING
	<p style="text-align: center;">IMPORTANT SAFETY INFORMATION INSIDE</p> <ul style="list-style-type: none"> • Serious injury or death possible. • Read, understand, and follow all safety information and instructions in this manual before using or servicing this product. • Retain these instructions for future reference.

CONTENTS

Specifications	Page 2
YES Installation	Page 3
FES Assembly	Page 4
Wiring	Page 4,5,6,7,8
Operating	Page 9
Replacement Parts	Page 10,11
Maintenance	Page 12
Limited Warranty	Page 12

SPECIFICATIONS

Portable Electric Heaters – UL file number E154159

Model	Part number	kW	Volts	PH	Amps	Fan Output	Heat Output	Dim A
FES-1024-1CA	08860010	10	240	1	42	800 CFM	34152 BTUH	21"
FES-1520-3A	08860110	15	208	3	41.5	800 CFM	51228 BTUH	21"
FES-1524-1A	08860710	15	240	1	62.5	800 CFM	51228 BTUH	23"
FES-1524-3E	08860210	15	240	3	36	800 CFM	51228 BTUH	21"
FES-1548-3E	08860310	15	480	3	18	800 CFM	51228 BTUH	21"
FES-1560-3A	08860410	15	600	3	14.4	800 CFM	51228 BTUH	21"
FES-3048-3A	08860510	30	480	3	36	1100 CFM	102455 BTUH	23"
FES-3060-3A	08860610	30	600	3	30	1100 CFM	102455 BTUH	23"

Suspended Electric Heaters – UL file number E32304

Model	Part number	kW	Volts	PH	Amps	Fan Output	Heat Output	Dim B
YES-1024-1CA	08861510	10	240	1	42	800 CFM	34152 BTUH	36"
YES-1520-3A	08860810	15	208	3	41.5	800 CFM	51228 BTUH	36"
YES-1524-1A	08861810	15	240	1	62.5	800 CFM	51228 BTUH	38"
YES-1524-3E	08860910	15	240	3	36	800 CFM	51228 BTUH	36"
YES-1548-3E	08861010	15	480	3	18	800 CFM	51228 BTUH	36"
YES-1560-3A	08861110	15	600	3	14.4	800 CFM	51228 BTUH	36"
YES-3048-3A	08861210	30	480	3	36	1100 CFM	102455 BTUH	38"
YES-3060-3A	08861310	30	600	3	30	1100 CFM	102455 BTUH	38"

Description – Fostoria portable and suspended electric heaters provide clean, quiet, odor-free, fan-forced heat. They are designed to circulate room air continuously; gradually heating a confined space. The best results will be obtained when using these heaters in smaller, insulated spaces. Features include a safety-yellow enclosure with front and rear safety screens; reliable stainless steel finned heating elements; a high-limit temperature switch with automatic reset; an automatic thermostat control with fan-only option; and a long-life motor and fan assembly with sealed bearings. The portable (FES) models come mounted on a two-wheeled cart with wheels designed to be easily pushed or pulled over uneven surfaces.

FES Models

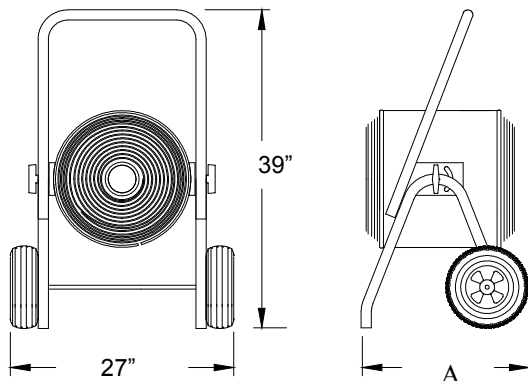

YES Models

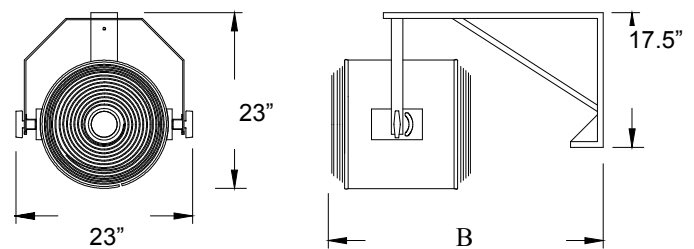

YES models are shipped with the following items. Check to make certain all parts are at hand prior to beginning the installation.

All Fostoria FES models come fully-assembled except the handle is attached in a lowered shipping position when shipped from the factory. Dimensions above are for handle in operating position. See page 4 for final assembly of handle.

Quantity	Description	Quantity	Description
1	Bracket wall/ceiling	1	Rotating stop - Top
1	Hanger	1	Nut stop ½ -13
2	Washer steel	1	Bolt ½-13 x 1-1/2
2	Knob	1	Nylon washer
2	Washer rubber	2	Rotating stop – side

YES - SERIES INSTALLATION

ALL Fostoria YES models require some assembly. Four steps are required to complete the assembly and installation.

Tools required: (2) 3/4" socket or box wrenches.

Parts required: the two screws required to secure wall/ceiling bracket to a suitable surface are not supplied with heater. You must use 5/16" bolts and flat washers to mount this bracket.

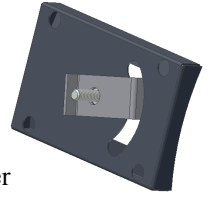

Step 1: Install (1) side rotating stop over bolt and into curved slot (as shown at right) on each side of heater.

Step 2: Assemble hanger to heater per hanger assembly detail. No tools are required.

Step 3: Secure wall/ceiling mounting bracket to appropriate surface that will support a min. weight of 100lbs continuously. NOTE: all mounting hardware to mount hanger to wall/ceiling bracket is supplied with heater.

Step 4: Assemble unit to mounting bracket following instructions of chosen mounting option below.

Hanger Assembly Detail

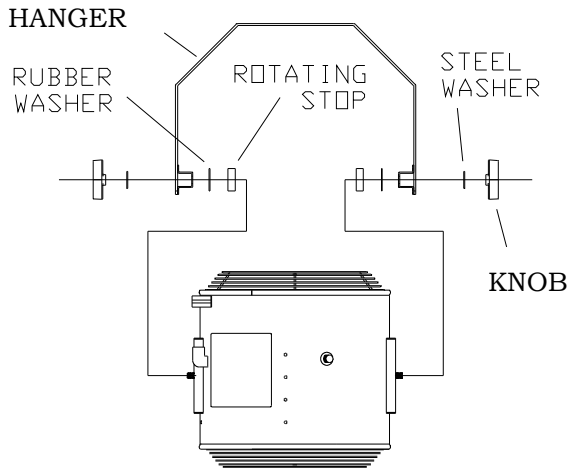

Ceiling Mount Option

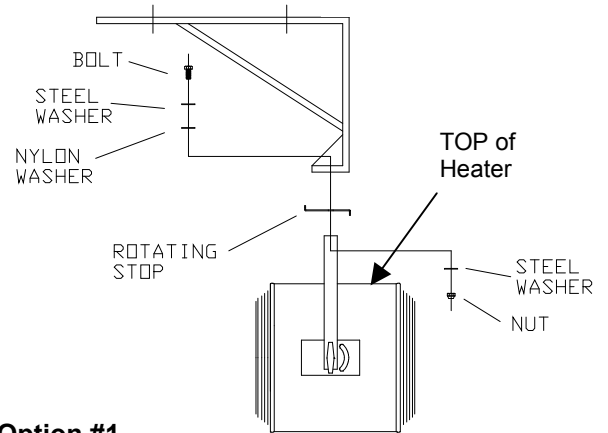

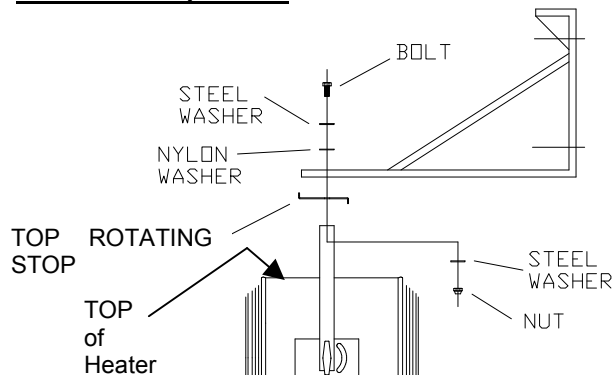

Wall Mount Option #1

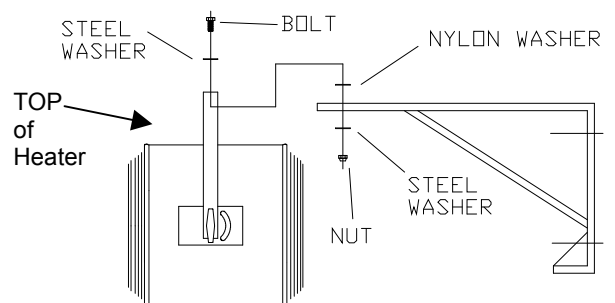

Wall Mount Option #2



  	⚠ WARNING
	FALLING OBJECTS HAZARD FIRE HAZARD
	<ul style="list-style-type: none"> Serious injury or death may occur. Read and follow all safety information and instructions in box below.
	<ul style="list-style-type: none"> Mounting bracket supplied with YES models <u>MUST</u> be used to support heater. Installer <u>MUST</u> be certain surface that bracket is mounted to will support 100 lbs of weight continuously. Rotating stops <u>MUST</u> be installed as shown above. Do not mount heater upside down (See nameplate label for "TOP" of heater.) The bottom of these units must be mounted at least 6 ft. off the floor and the top 2 ft. from the ceiling. Do not suspend <u>ANY</u> other equipment from this bracket. One heater per bracket maximum.

FES – SERIES ASSEMBLY

Tools Required: (2) 7/16" socket or box wrenches.

To position the handle at operating height:

Step 1: Remove and keep the hardware securing the handle to the legs.

Step 2: Raise handle until holes align with the upper holes in the legs.

Step 3: Re-insert hardware as shown, and fasten securely.

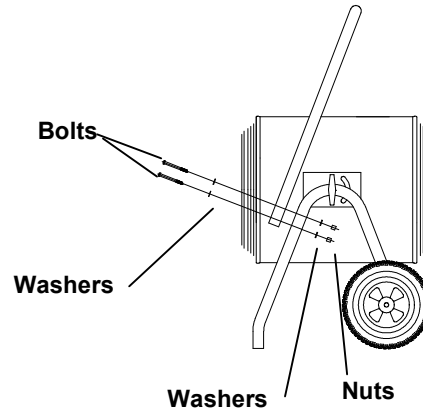

WIRING

THE PROPER SIZE SO- type feeder cable MUST BE USED for the electrical hook-up of this heater. The proper cable size is shown in the tables below (A.W.G./ # of conductors.) Table 1 is for cable 50ft. in length or less. Table 2 is for cable longer than 50ft.

A 25ft. cable kit can be purchased from the factory. Refer to the kit part numbers in table at right.

CABLE KITS INCLUDE:

- 25 feet of Type SO cable, with either 3-conductors or 4-conductors, depending on the heater requirements.

Model Table 1	Unit Rating	Cable Size - Under 50ft. long	Cable Kit Number
FES & YES 1520-3A	15kW, 208 Volt, 3-Ph	6/4	03164001
FES & YES 1524-1A	15kW, 240 Volt, 1-Ph	4/3	08805300
FES & YES 1524-3E	15kW, 240 Volt, 3-Ph	6/4	03164001
FES & YES 1548-3E	15kW, 480 Volt, 3-Ph	12/4	03164201
FES & YES 1560-3A	15kW, 600 Volt, 3-Ph	12/4	03164201
FES & YES 3048-3A	30kW, 480 Volt, 3-Ph	6/4	03164001
FES & YES 3060-3A	30kW, 600 Volt, 3-Ph	6/4	03164001

Model Table 2	Unit Rating	Cable Size – Over 50ft. long	Max. Cable Length (ft)
FES & YES 1520-3A	15kW, 208 Volt, 3-Ph	4/4	120
FES & YES 1524-1A	15kW, 240 Volt, 1-Ph	2/3	215
FES & YES 1524-3E	15kW, 240 Volt, 3-Ph	6/4	150
FES & YES 1548-3E	15kW, 480 Volt, 3-Ph	12/4	140
FES & YES 1560-3A	15kW, 600 Volt, 3-Ph	12/4	190
FES & YES 3048-3A	30kW, 480 Volt, 3-Ph	6/4	300
FES & YES 3060-3A	30kW, 600 Volt, 3-Ph	6/4	350

To order cable kits
Phone: 1-800-495-4525

- Feeder cable or cable kit assembly **MUST BE** made by licensed electricians **ONLY**.
- Service panel or receptacle used to supply power to these heaters **MUST** have a ground bus or ground pole that is securely bonded to earth ground.
- Connect green ground conductor on feeder cable or cable kit to grounding lug on heaters.
- Comply with **ALL** local electrical codes and the National Electric Code (NFPA70) when providing electrical power to these heaters.



⚠ WARNING

ELECTRICAL SHOCK HAZARD FIRE HAZARD

- Serious injury or death may occur.
- Disconnect from electrical supply before installing feeder cable to these heaters.
- Read and follow all safety information in box to the left.

WIRING (continued)

FES-1024-1CA YES-1024-1CA

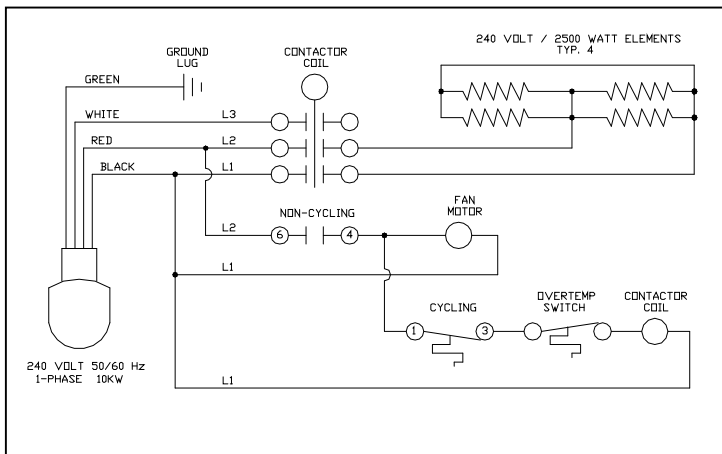

Models FES-1024-1CA and YES-1024-1CA are shipped with a cordset factory-installed. This cordset contains a plug for use with a 50A household range receptacle. The blade configuration on the plug included on these heaters is represented in fig. 1 below (4-wire circuit).

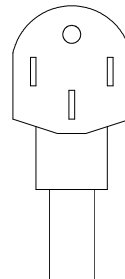

fig. 1

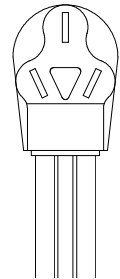

fig. 2

The range receptacle you choose to use may have a blade configuration compatible with the plug shown in fig. 2 (3-wire circuit). This is an older branch circuit design that does not include a separate equipment grounding conductor (green wire). The configuration in fig. 1 has been implemented on newer branch circuit installations for increased safety, and is now the required circuit configuration by the National Electric Code. Changing a 3-wire branch circuit and receptacle to 4-wire design may involve changes to your range and must only be done by a licensed electrician.

WARNING

ELECTRICAL SHOCK
HAZARD

- **Serious injury or death may occur.**
- **Plug heater into a 4-wire circuit receptacle rated 50A.**
- **Any and all changes to branch circuits and receptacles MUST be done by a licensed electrician ONLY.**

WIRING (continued)

FES-1524-1A YES-1524-1A

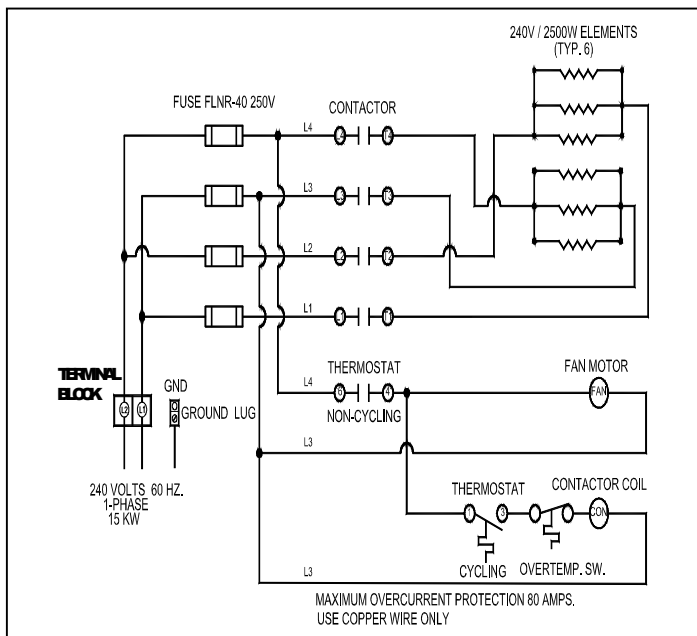

FES-1524-1A YES-1524-1A

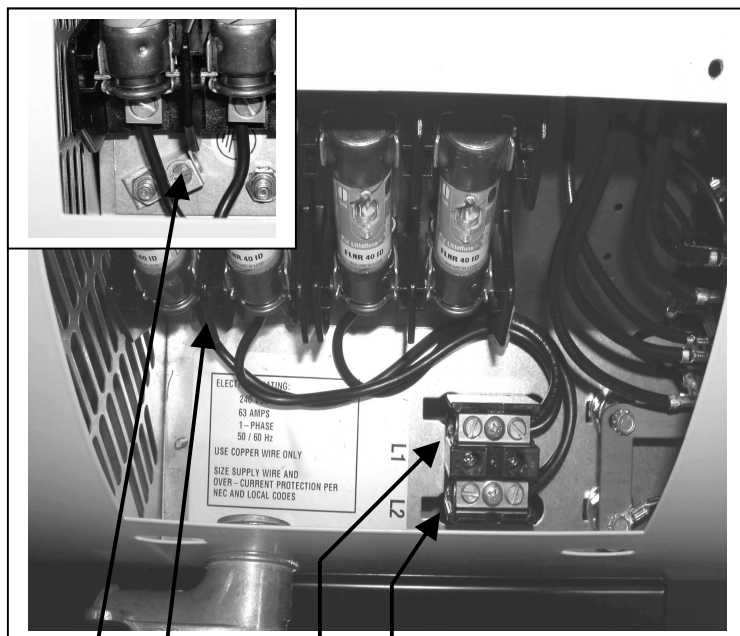

Attach feeder cable or cable kit to heater as shown in photograph at right for the single-phase models indicated.

Ground lug is located directly below fuse as shown in upper left corner. Securely attach green wire to this lug.

Attach circuit conductors at these lugs. Refer to label shown for phase identification

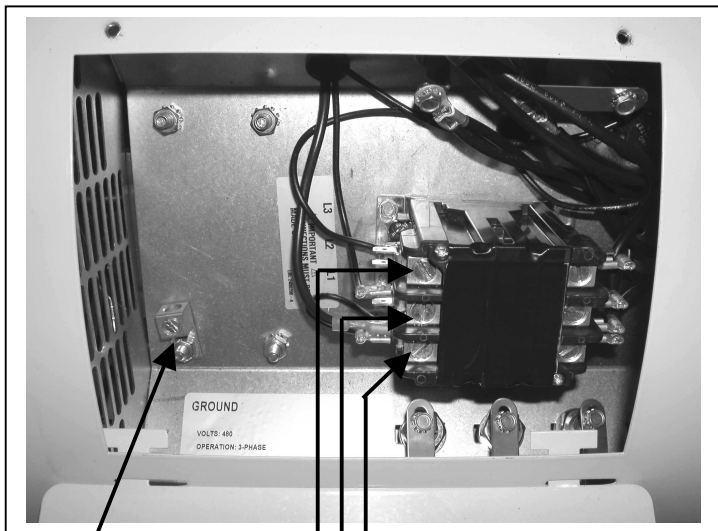

3-Phase Models

Attach feeder cable or cable kit to heater as shown in the photograph at left for the following 3-phase models.

FES-1520-3A	YES-1520-3A
FES-1524-3E	YES-1524-3E
FES-1548-3E	YES-1548-3E
FES-1560-3A	YES-1560-3A
FES-3048-3A	YES-3048-3A
FES-3060-3A	YES-3060-3A

Ground Lug
Securely attach green wire to this lug.

Attach circuit conductors to the lugs on the contactor. Refer to label shown for phase identification.

WIRING (continued)

FES & YES 3- PHASE WIRING DIAGRAMS

FES-1524-3E YES-1524-3E

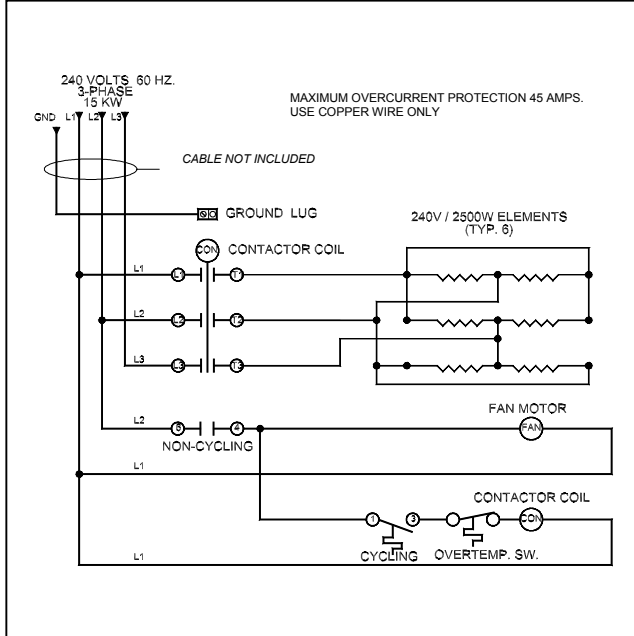

FES-1520-3A YES-1520-3A

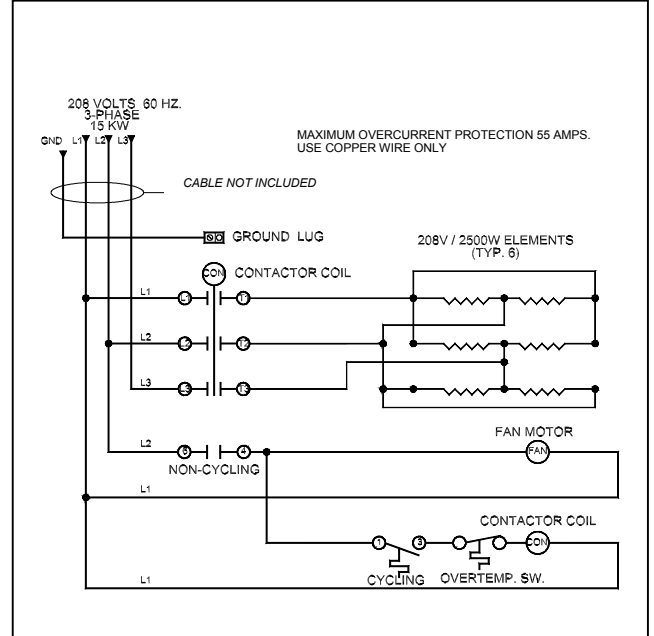

FES-1548-3E YES-1548-3E

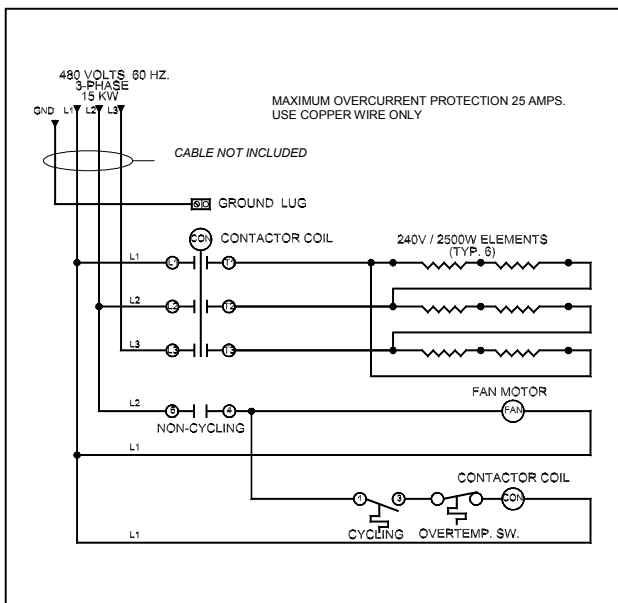

FES-1560-3A YES-1560-3A

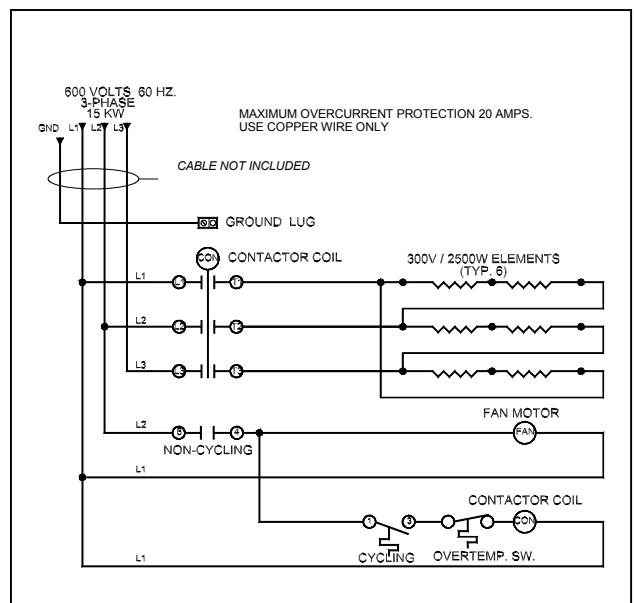

WIRING (continued)

FES & YES 3-PHASE WIRING DIAGRAMS

FES-3048-3A

YES-3048-3A

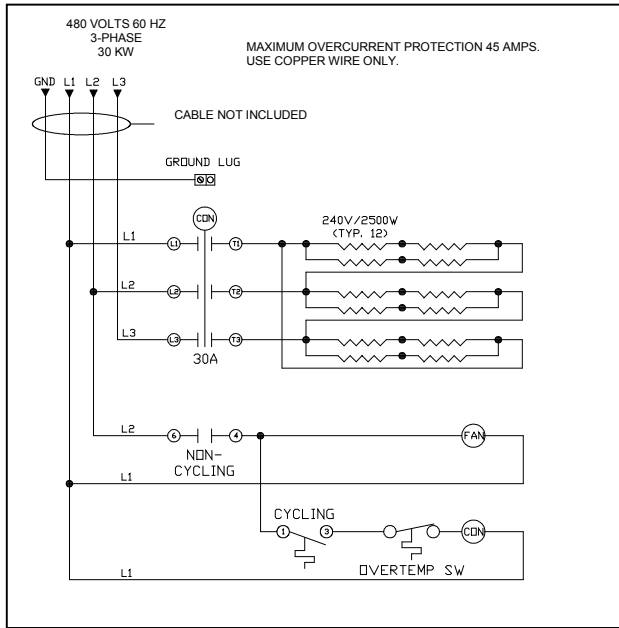

FES-3060-3A

YES-3060-3A

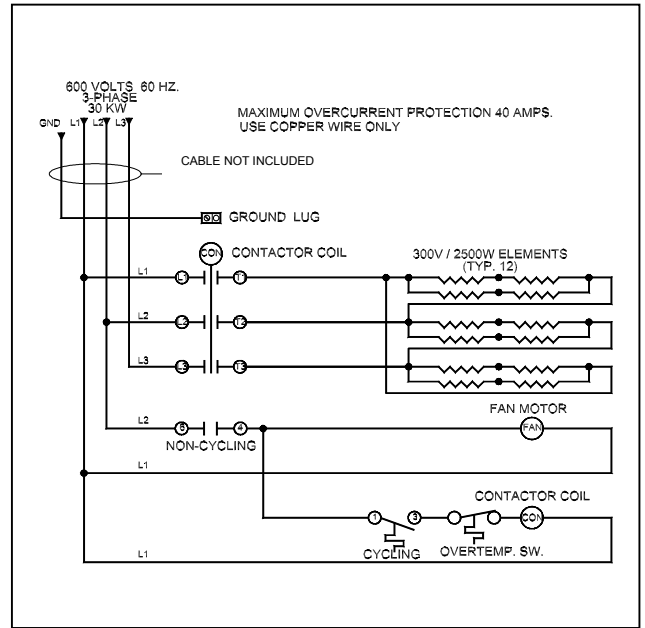

OPERATING INSTRUCTIONS

Fostoria FES and YES series heaters are designed to circulate room air across its heating elements to gradually increase room temperature. The best performance results will be obtained when using these heaters in smaller, confined spaces with low ceilings.

Operation of these heaters is accomplished via the use of a multi-function thermostat (refer to diagram below).

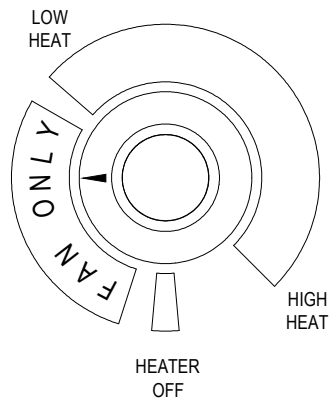





You have the option to use the fan only*, or the fan and heating elements together. Position the knob pointer in the “fan-only” area to circulate room air with no heating. Move the pointer into the “heat” area to energize the heating elements and set the thermostat. Maximum heating is obtained with knob turned fully clockwise**. Both fan and elements are off when the knob is turned fully counterclockwise.

Allow the fan to operate for a minimum of 3 minutes when you are done using the heater to purge heat from unit.

***The thermostat has a preset range of 40°F to 100°F. If the ambient room temperature is below 40°F, there will be no “fan only” function as the thermostat is always calling for heat.**

****Setting the thermostat to high heat versus low heat does not make the unit operate at a higher temperature. It simply raises the temperature necessary to satisfy the thermostat. The unit will run longer to try to satisfy a higher thermostat setting.**

Note: ALL FES/YES models are equipped with an internal over temperature limit designed to protect your heater if a restricted airflow condition occurs. This limit device will completely shutdown the heating elements if the temperature limit is reached. The limit will automatically reset when the unit cools.

 WARNING	
  	FIRE HAZARD EXPLOSION HAZARD BURN HAZARD
	<ul style="list-style-type: none">• Serious injury or death may occur.
	<ul style="list-style-type: none">• Read and follow all safety information in box below.
<ul style="list-style-type: none">• Do not use outdoors or where flammable gases or liquids are stored.• Do not use as a residential comfort heater.• Keep portable heater 3ft. minimum from all combustible materials at all times.• Do not modify heater in any way.• Do not provide power to heater when unit is near standing water.• Only use handle to move heater.• Do not touch heater housing while in use.• Do not allow feeder cable to contact combustible materials.• Always purge heat from unit after use. Operate at “fan only” setting for 3 minutes.	

FES REPLACEMENT PARTS LIST & EXPLODED VIEWS

Ref No.	Description	1024-1CA	1520-3A	1524-3E	1548-3E	1560-3A	3048-3A	3060-3A
1	Motor	8482001 (1)	8482001 (1)	8482001 (1)	8482002 (1)	8482003 (1)	8482004 (1)	8482005 (1)
2	Bolt carriage 1/2-13 x 2-3/4	2470132 (2)	2470132 (2)	2470132 (2)	2470132 (2)	2470132 (2)	2470132 (2)	2470132 (2)
3	Rotating stop	8481223 (2)	8481223 (2)	8481223 (2)	8481223 (2)	8481223 (2)	8481223 (2)	8481223 (2)
4	Thermostat	2470300 (1)	2470300 (1)	2470300 (1)	2470300 (1)	2470300 (1)	2470300 (1)	2470300 (1)
5	Washer Reducing (not shown)	N/A	N/A	N/A	2485400 (2)	2485400 (2)	N/A	N/A
6	Knob thermostat	2470500 (1)	2470500 (1)	2470500 (1)	2470500 (1)	2470500 (1)	2470500 (1)	2470500 (1)
7	Strap	2470800 (1)	2470800 (1)	2470800 (1)	2470800 (1)	2470800 (1)	2470800 (1)	2470800 (1)
8	Shroud	8480910 (1)	8480910 (1)	8480910 (1)	8480910 (1)	8480910 (1)	8481110 (1)	8481110 (1)
9	Motor mount bracket	8480801 (1)	8480801 (1)	8480801 (1)	8480801 (1)	8480801 (1)	8480800 (1)	8480800 (1)
10	Screw 10-32x 5/16 SEMS	2470932 (8)	2470932 (12)	2470932 (12)	2470932 (12)	2470932 (12)	2470932 (24)	2470932 (24)
11	Mount motor end	8480700 (2)	8480700 (2)	8480700 (2)	8480700 (2)	8480700 (2)	8480700 (2)	8480700 (2)
12	Washer 9/16	3419500 (8)	3419500 (12)	3419500 (12)	3419500 (12)	3419500 (12)	3419500 (24)	3419500 (24)
13	Nut hex 1/4-20	3426000 (4)	3426000 (4)	3426000 (4)	3426000 (4)	3426000 (4)	3426000 (4)	3426000 (4)
14	Washer 1/4	3427900 (8)	3427900 (8)	3427900 (8)	3427900 (8)	3427900 (8)	3427900 (8)	3427900 (8)
15	Grill	8480621 (2)	8480621 (2)	8480621 (2)	8480621 (2)	8480621 (2)	8480621 (2)	8480621 (2)
16	Washer	2472032 (4)	2472032 (4)	2472032 (4)	2472032 (4)	2472032 (4)	2472032 (4)	2472032 (4)
17	Screw 8-18 x 1/2	3444456	3444456	3444456	3444456	3444456	3444456	3444456
18	Contact	8480402 (1)	8480402 (1)	8480400 (1)	8480401 (1)	8480403 (1)	8480401 (1)	8480403 (1)
19	Cordset - not shown	3171701 (1)	-----	-----	-----	-----	-----	-----
20	Nut 1/2-13	3460200 (2)	3460200 (2)	3460200 (2)	3460200 (2)	3460200 (2)	3460200 (2)	3460200 (2)
21	Screw 1/4-20 x 3/4	3494156 (4)	3494156 (4)	3494156 (4)	3494156 (4)	3494156 (4)	3494156 (4)	3494156 (4)
22	Over temperature switch	3183900 (1)	3183900 (1)	3183900 (1)	3183900 (1)	3183900 (1)	41041001 (1)	41041001 (1)
23	Ground Lug	41254001 (1)	41254001 (1)	41254001 (1)	41254001 (1)	41254001 (1)	41254001 (1)	41254001 (1)
24	Connector	7714122 (1)	7714122 (1)	7714122 (1)	2485300 (1)	2485300 (1)	7714122 (1)	7714122 (1)
25	Baffle - not shown	8483800 (1)	8483800 (1)	8483800 (1)	8483800 (1)	8483800 (1)	8483800 (1)	8483800 (1)
26	Bussbar - not shown	8421600 (4)	8421600 (8)	8421600 (8)	8421600 (5)	8421600 (5)	8421600 (10)	8421600 (10)
27	Element inner	8481401 (2)	8481403 (3)	8481401 (3)	8481401 (3)	8481405 (3)	8481401 (6)	8481405 (6)
28	Element outer	8481402 (2)	8481404 (3)	8481402 (3)	8481402 (3)	8481406 (3)	8481402 (6)	8481406 (6)
29	Blade fan - not shown	8422300 (1)	8422300 (1)	8422300 (1)	8422300 (1)	8422300 (1)	8422300 (1)	8422300 (1)
30	Cover	8481010 (1)	8481010 (1)	8481010 (1)	8481010 (1)	8481010 (1)	8481010 (1)	8481010 (1)

GRILL ATTACHMENT

THERMOSTAT

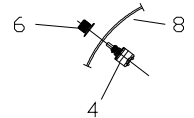
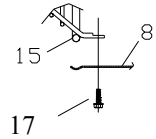

ROTATING STOP

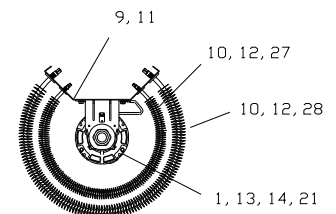
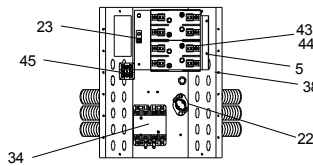
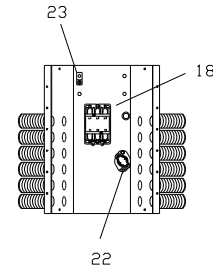
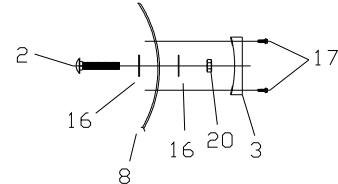
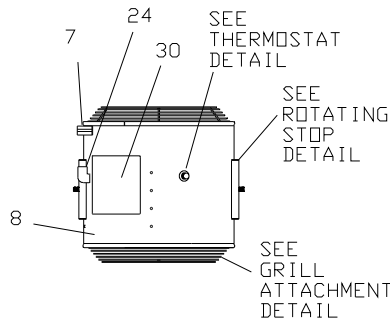

Ref No.	Description	1524-1A
1	Motor	8482001 (1)
2	Bolt carriage 1/2-13 x 2-3/4	2470132 (2)
3	Rotating stop	8481223 (2)
4	Thermostat	2470300 (1)
5	Washer reducing (not shown)	N/A
6	Knob thermostat	2470500 (1)
7	Strap	2470800 (1)
8	Shroud	8481110 (1)
9	Motor mount bracket	8480800 (1)
10	Screw 10-32x 5/16 SEMS	2470932 (12)
11	Mount motor end	8480700 (2)
12	Washer 9/16	3419500 (12)
13	Nut hex 1/4-20	3426000 (4)
14	Washer 1/4	3427900 (10)
15	Grill	8480621 (2)
16	Washer	2472032 (4)
17	Screw 8-18 x 1/2	3444456
18	Contact	8480406 (1)
19		
20	Nut 1/2-13	3460200 (2)
21	Screw 1/4-20 x 3/4	3494156 (4)
22	Over temperature switch	3183900 (1)
23	Ground Lug	41254001 (1)
24	Connector	7714122 (1)
25	Baffle-not shown	8483800 (1)
26	Bussbar - not shown	8421600 (8)
27	Element inner	8481401 (3)
28	Element outer	8481402 (3)
29	Blade fan - not shown	8422300 (1)
30	Cover	8481010 (1)
31	Bracket fuse block	8481700 (1)
32	Fuse block	8481600 (2)
33	Fuse type FLNR-40 250V	71031471 (4)
34	Terminal block	51243002 (1)

FES REPLACEMENT PARTS LIST & EXPLODED VIEWS

Ref No.	Description	Part No.
1	Handle	8480021
2	Washer flat ¼	3442532
3	Screw ¼-20 x 2-3/4	2470032
4	Nut stop ¼-20	3440132
5	Axle	8481332
6	Cap plug	3409200
7	Leg	8480121
8	Washer rubber	2480200
9	Spacer	8480500
10	Washer flat ½	3460156
11	Wheel	8492500
12	Push nut	8045700
13	Bar Knob	2470200
14	Spacer	2471932
15	Washer lock ¼	3427900
16	Screw ¼-20 x 1-3/4	2471832

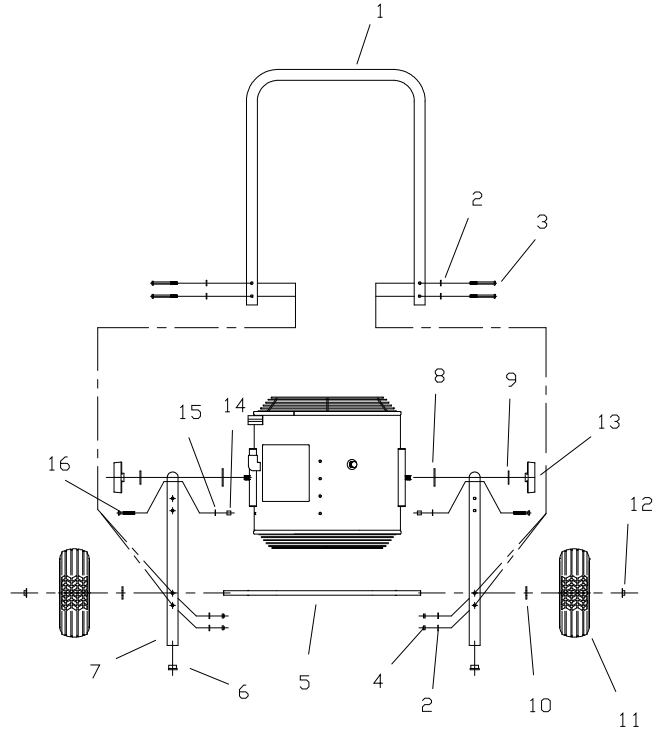

YES REPLACEMENT PARTS LIST & EXPLODED VIEWS

Ref No.	Description	Part No.	Qty.
1	Hanger	8484023	1
2	Washer rubber	2480200	2
3			
4	Bar knob	2470200	2
5	Mounting bracket	57074002	1
6	Washer fender	3472232	4
7	Washer nylon	3443700	1
8	Rotating stop	8483923	1
9	Nut stop ½-13	3446432	1
10	Screw ½-13 x 1-1/2	2480132	1
11	Rotating Stop – Side	8484423	2

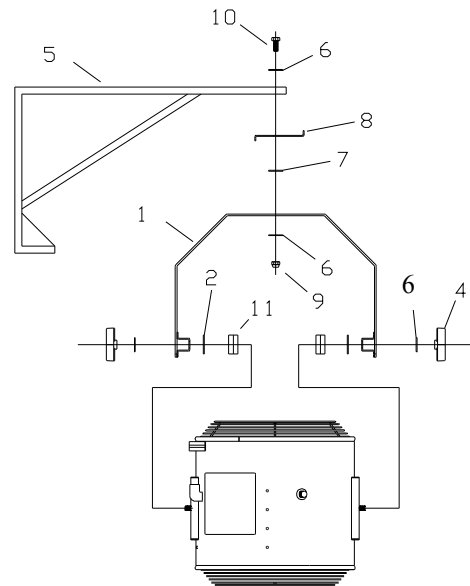

**To convert an FES unit to a YES unit
order the Fostoria kit Model WMK-FES
p/n 04804102.**

MAINTENANCE

Other than periodic cleaning of the exterior, no maintenance is required for these heaters.

- Do not hose these units down.
- Remove dust and dirt from inside heater with compressed air.
- Do not operate these heaters without the grills or the wiring compartment cover in place.
- Replace or repair feeder cable or cord set if visible damage is observed.
- Motor bearings are permanently lubricated.



! WARNING

ELECTRICAL SHOCK HAZARD

- **Serious injury or death may occur.**
- **Disconnect from electrical supply before servicing or cleaning these heaters.**
- **Do not operate without grills and access covers fastened in place.**

LIMITED WARRANTY

FOSTORIA INDUSTRIES, INC. – 1200 North Main Street - Fostoria, Ohio 44830-1911 - (419) 435-9201

The warranty herein set forth is in lieu of all other warranties expressed or implied.

Fostoria Industries, Inc. of Fostoria, Ohio 44830, warrants its products to the owner against defects in material and workmanship for a twelve (12) month period under normal use and service following date of manufacture or installation when proof of such is provided to seller.

This Warranty requires that the owner, or his agent, install the equipment in accordance with the National Electrical Code, any other applicable heating or electrical codes and the manufacturer's installation instructions. It further requires that he perform reasonable and necessary maintenance on the unit. The company is not liable for abuse or misuse of product as may be finally determined by the company.

The obligation of Fostoria Industries, Inc. under the terms of this warranty, shall be to supply a new part, repair of defective part, or a refund, at the company's option with no cost to owner for the new or repaired part. Such parts are to be returned to the factory, or such other location as the company may designate. This warranty does not obligate Fostoria Industries, Inc. to bear the cost of labor in replacing any assembly, unit or component part thereof, nor does the company assume any liability for secondary charges, expenses for installing or removal, or any other consequential losses. The company's maximum liability shall not in any case exceed the list price for the product claimed to be defective.

The warranty shall not apply to any product or parts of products which have been repaired or altered outside of Seller's factory in any manner. Warranty is void on products that have been determined to have been subjected to misuse, negligence or accident or which have been used in a manner contrary to Seller's instructions.

FOSTORIA INDUSTRIES, INC.
 1200 North Main Street
 Fostoria, OH 44830-1911
 Phone: 800-495-4525
 Fax: 419-435-0842
 www.fostoriaindustries.com

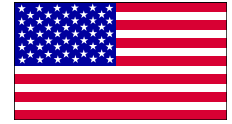

Fabricamos productos de calidad desde 1917

UNA DIVISIÓN DE 

SUN-MITE





 Si usted tiene las preguntas acerca del producto usted ha comprado o querría salirnos reacción por favor nos contacta vía nuestro sitio web www.fostoriaindustries.com o llamando 1-800-495-4525.

FES - Serie
 Calentadores Eléctrico
 Portátiles



(FES - 1524 - 3E mostrado)

YES - Serie
 Calentadores Eléctrico
 Suspendido

	 ADVERTENCIA
	<p>IMPORTANTE INOCUIDAD INFORMACIÓN DENTRO</p> <ul style="list-style-type: none"> • Lesión seria o posible de muerte. • Lea, comprenda, y siga toda información de seguridad e instrucciones en este manual antes de usar o atienda este producto. • Conserve estas instrucciones para futuras consultas.

Contenido

Especificaciones	Página 14
Instalación de YES	Página 15
Asamblea de FES	Página 16
Cableado	Página 16,17,18,19,20
Operar	Página 21
Partes de reemplazo	Página 22,23
Mantenimiento	Página 24
Garantía limitada	Página 24

ESPECIFICACIONES

Calentadores Eléctricos Portátiles – E154159 de número de archivo de UL

Modelo	Número de parte	KW	Voltios	Fase	Amperios	Producto de soplador	Producto de Calor	Mida A
FES - 1024 -1CA	08860010	10	240	1	42	800 CFM	34152 BTUH	21 "
FES - 1520 - 3A	08860110	15	208	3	41.5	800 CFM	51228 BTUH	21 "
FES - 1524 - 1A	08860710	15	240	1	62.5	800 CFM	51228 BTUH	23 "
FES - 1524 - 3E	08860210	15	240	3	36	800 CFM	51228 BTUH	21 "
FES - 1548 - 3E	08860310	15	480	3	18	800 CFM	51228 BTUH	21 "
FES - 1560 - 3A	08860410	15	600	3	14.4	800 CFM	51228 BTUH	21 "
FES - 3048 - 3A	08860510	30	480	3	36	1100 CFM	102455 BTUH	23 "
FES - 3060 - 3A	08860610	30	600	3	30	1100 CFM	102455 BTUH	23 "

Colgó Calentadores Eléctricos - E32304 de número de archivo de UL

Modelo	Número de parte	KW	Voltios	Fase	Amperios	Producto de ventilador	Producto de Calor	Mida B
YES - 1024 -1CA	08861510	10	240	1	42	800 CFM	34152 BTUH	36 "
YES - 1520 - 3A	08860810	15	208	3	41.5	800 CFM	51228 BTUH	36 "
YES - 1524 - 1A	08861810	15	240	1	62.5	800 CFM	51228 BTUH	38 "
YES - 1524 - 3E	08860910	15	240	3	36	800 CFM	51228 BTUH	36 "
YES - 1548 - 3E	08861010	15	480	3	18	800 CFM	51228 BTUH	36 "
YES - 1560 - 3A	08861110	15	600	3	14.4	800 CFM	51228 BTUH	36 "
YES - 3048 - 3A	08861210	30	480	3	36	1100 CFM	102455 BTUH	38 "
YES - 3060 - 3A	08861310	30	600	3	30	1100 CFM	102455 BTUH	38 "

Descripción – Los calentadores de Fostoria, portátil y suspendido proveen el calor forzado por ventilador. Son limpienza, silencioso, y olor gratis. Son diseñados circular aire de habitación constantemente; calentando un espacio limitado gradualmente. Los mejores resultados serán obtenidos Cuándo usan estos calentadores en espacios más pequeños y aislados. Las características incluyen un cercamiento seguridad - amarillo con frente y traseras seguridad biombo; Elementos de calefacción con aletas de acero inoxidable confiables; un interruptor de temperatura alto - límite, con el revés automático; un control de termostato automático con la alternativa ventilador - solamente; y un motor de vida largo y asamblea de ventilador con cojinete cerrado. El modelo de calentador portátil (FES) es instalado en un carro de dos giraron con ruedas diseñadas ser empujado fácilmente o jalado sobre superficies irregulares.

Modelos de FES

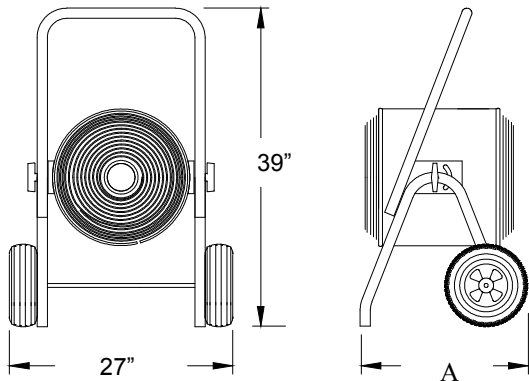

Modelos de YES

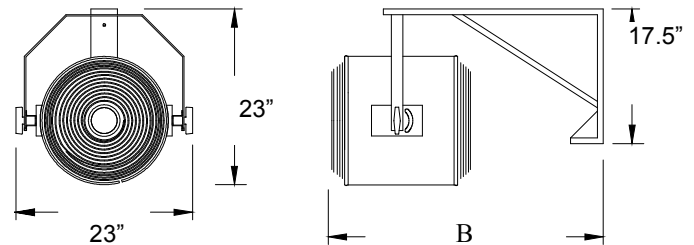

Los modelos de YES incluir lo siguiente artículos. Verifique para asegurarse que todas partes están cerca antes de empezar la instalación.

Todos modelos de Fostoria, vienen montados totalmente menos el asa. El asa está montada en un puesto de envío. Dimensiones más arriba son para asa en el puesto operativo. Vea Página 4 para la asamblea final de asa.

Cantidad	Descripción	Cantidad	Descripción
1	Pared / techo de corchete	1	Tope rotativa - Alto
1	Percha	1	La parada de nuez ½ x 13
2	Acero de arandela	1	½ - 13 x 1-1/2 de - perno
2	Pomo	1	Arandela de nilón
2	Goma de arandela	2	Tope rotativa – de lado

YES - INSTALACIÓN DE SERIE

Todos modelos de YES de Fostoria requieren un poco de ensamblaje. Cuatro pasos son requeridos terminar la asamblea y la instalación.

Herramientas requerían: (2) 3/4" Llave inglesa

Requerir: los dos tornillos requeridos instalar el corchete de pared / techo. No ser proporcionado con calentador. Usted debe usar pernos 5/16 " y arandela bemol .

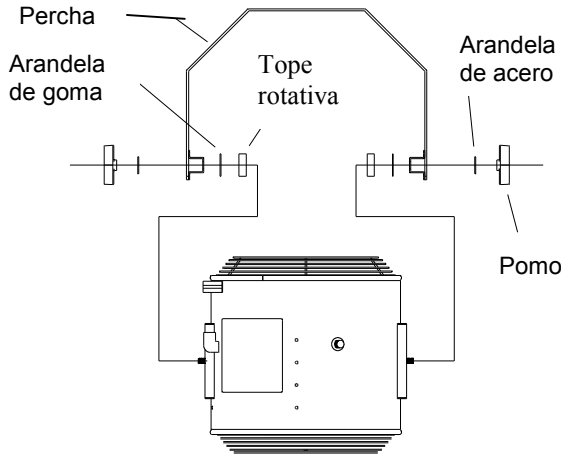

Paso 1: instale (1) girando parada sobre perno y en solt curvado (como mostrado en el derecho) sobre cada costado de calentador.



Paso 2: monte percha to calentador por el detalle de la asamblea de percha. Ninguna herramienta es requeridas.

Paso 3: Corchete de pared / techo de instalación para la superficie apropiada que respaldará un peso de minimum de 100 libra. Nota: los pernos son suministrados.

Paso 4: Montar unidad para corchete siga a instrucciones elegidos abajo.

ELECCION DE MONTURA DE TECHO

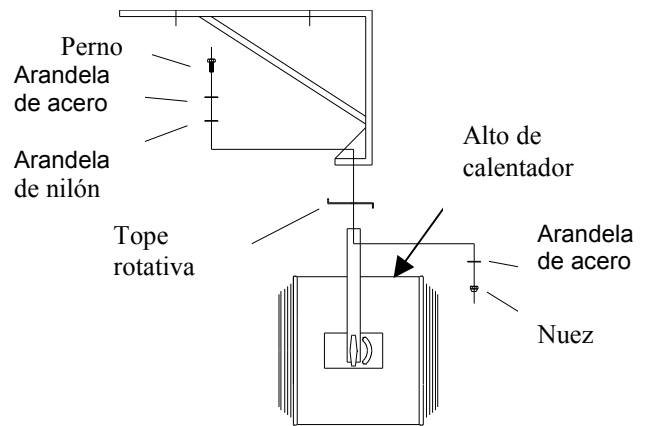

1 DE OPCIÓN DE MONTURA DE PARED

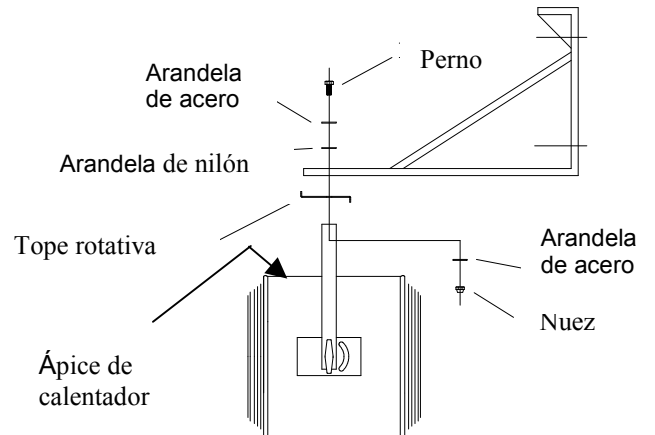

2 DE OPCIÓN DE MONTURA DE PARED

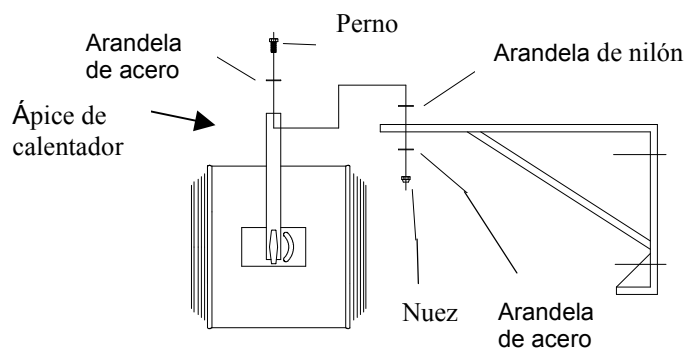

⚠ ADVERTENCIA

PELIGRO DE OBJETOS CAYENDO PELIGRO DE INCENDIO

- Perjuicio serio o muerte podrían ocurrir.
- Lea y siga toda información de seguridad y instrucciones abajo

- El corchete enviado con calentador debe serlo usar.
- La superficie a la que esa repisa es instalada debe respaldar 100 libra de peso ininterrumpido.
- Tope rotativa debe ser instalado como mostrado arriba.
- No instale calentador al revés. Mire la etiqueta para la punta de calentador.
- Calentador de montura al menos 6 s pie de piso y 2 pies de techo.
- No cuelgue cualquier otro equipo de este corchete. Un calentador por el corchete máximo.

FES - asamblea de serie

Herramientas requerían: (2) 7/16 " llaves inglesas de caja.

Para colocar el asa en la altura operativa:

Paso 1: Se quitar y guarde el pertrechos que fija el asa a las piernas.

Paso 2: Se levantar el asa hasta que los agujeros se alinean con el alto agujeros en las piernas.

Paso 3: Vuelva a introducir pernos como mostrado, y abroche afianzar.

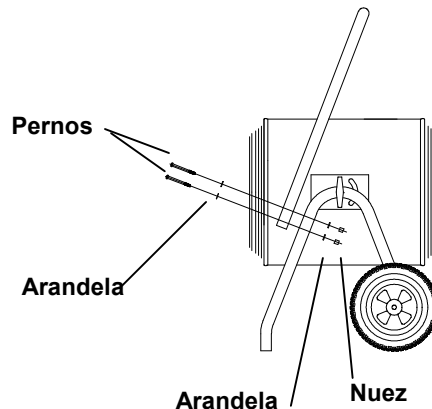

Cableado

El alimentador cable de - tipo SO debe ser usado para la conexión eléctrica de este calentador. El tamaño de cable correcto es mostrado en las mesas abajo (A.W.G./ # de alambres.) El Cuadro 1 es para el cable 50 pies de longitud o menos. El Cuadro 2 es para el cable más largo que 50 pies.

Un producto de cable 25 pies puede ser comprado de la fábrica. Mire los números de producto en la tabla en el derecho.

CABLE PRODUCTO INCLUYEN:

- 25 pies de cable de Type SO, con cualquier 3 - directores o 4 directores, depender de los requisitos de calentador.

Modelo Table 1	Clasificación de unidad	Tamaño de cable - Bajo 50 pies	Cable Número de paquete
FES & YES 1520-3A	15kW, 208 voltio, 3 - Ph	6/4	03164001
FES & YES 1524-A	15kW, 240 voltio, 1 - Ph	4/3	08805300
FES & YES 1524-3E	15kW, 240 voltio, 3 - Ph	6/4	03164001
FES & YES 1548-3E	15kW, 480 voltio, 3 - Ph	12/4	03164201
FES & YES 1560-3A	15kW, 600 voltio, 3 - Ph	12/4	03164201
FES & YES 3048-3A	30kW, 480 voltio, 3 - Ph	6/4	03164001
FES & YES 3060-3A	30kW, 600 voltio, 3 - Ph	6/4	03164001

Modelo Table 2	Clasificación de unidad	Tamaño de cable - Mas de 50 pies	Max. Cable Longitud (pies)
FES & YES 1520-3A	15kW, 208 voltio, 3 - Ph	4/4	120
FES & YES 1524-A	15kW, 240 voltio, 1 - Ph	2/3	215
FES & YES 1524-3E	15kW, 240 voltio, 3 - Ph	6/4	150
FES & YES 1548-3E	15kW, 480 voltio, 3 - Ph	12/4	140
FES & YES 1560-3A	15kW, 600 voltio, 3 - Ph	12/4	190
FES & YES 3048-3A	30kW, 480 voltio, 3 - Ph	6/4	300
FES & YES 3060-3A	30kW, 600 voltio, 3 - Ph	6/4	350

Para pedir producto de cable

Teléfono: 1-800-495 - 4525

- Alimentador cable o ensamblaje de producto de cable deben ser hecho por electricistas SOLAMENTE autorizado.
- Panel eléctrico o tomas de corriente que son use proporcionar el poder a éstos calentadores deben tener una unidad terminal de tierra o varilla de tierra que son adheridas a tierra.
- Conecte a director de tierra verde sobre alimentador cable o producto cable a terminal sobre calentadores.
- Obedezca todos códigos eléctricos locales y el código eléctrico nacional (NFPA70) cuando proveer el poder eléctrico a estos calentadores.



ADVERTENCIA

PELIGRO DE CONMOCIÓN ELÉCTRICO PELIGRO DE INCENDIO

- Perjuicio serio o muerte podrían ocurrir.
- Desconéctele el suministro eléctrico antes de instalar el cable de alimentador a estos calentadores.
- Leer y siga información de seguridad todos a la izquierda.

FES-1024-1CA YES-1024-1CA

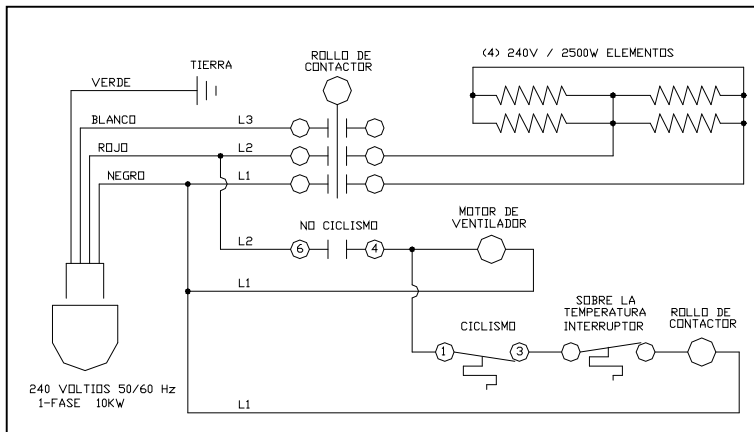

Modelos FES - 1024 - 1CA y YES - 1024 - 1CA enviar con un cordón instalado fábrica. Este cordón contiene un enchufe para el uso con uno 50 receptáculo de amperio eléctrico. La configuración de brizna sobre el enchufe incluida sobre estos calentadores es representada en higo. 1 abajo (el circuito 4 cable).



Figura 1



Figura 2

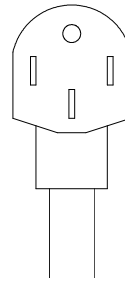

ADVERTENCIA

PELIGRO DE CONMOCIÓN ELÉCTRICA

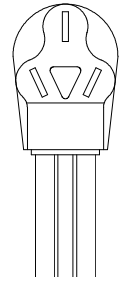
- Perjuicio serio o muerte podrían ocurrir.
- Calentador de enchufe a un 50A recipiente de circuito evaluar 4 cable.
- Todos cambios para circuitos de rama y recipientes deben ser hecho por un licencia electricista solamente.

El receptacle que usted decide usar podría tener una configuración de brizna compatible con el enchufe indicado en higo. 2 (el circuito 3 cable). Esto es un diseño de circuito de rama más viejo que no incluye a un director de restricción de conductor de conexión a tierra (cable verde). La configuración en higo. 1 ha sido implementado en las instalaciones de circuito de rama más nuevas para la inocuidad incrementar y es ahora la configuración de circuito requerida por el código eléctrico nacional. Cambiar un circuito de rama 3 cable y recipiente al diseño 4 cable puede involucrar los cambio a receptacle ser hecho por un electricista dado licencia solamente.

Cableado (continuado)

FES-1524-1A YES-1524-1A

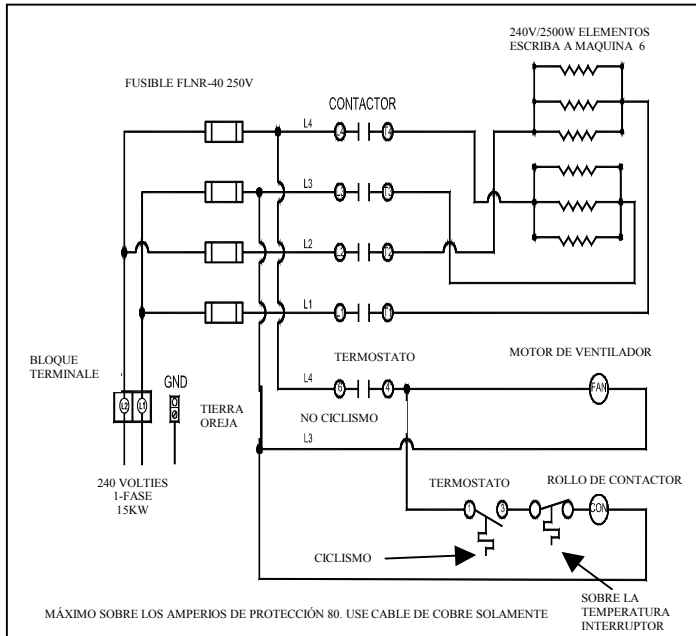

FES-1524-1A YES-1524-1A

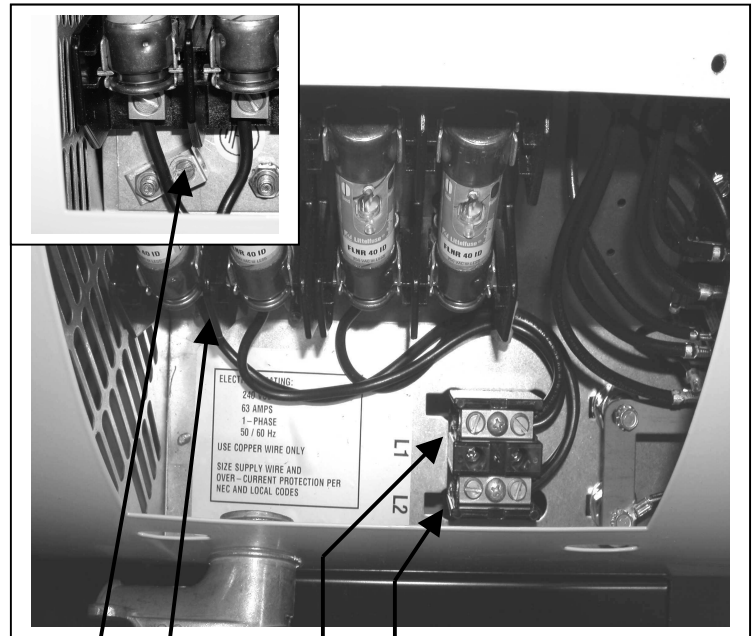

Conecte alimentador cable o producto de cable a calentador como mostrado en fotografía en el derecho, para los modelos solo - fase demostrados.

El tierra está ubicado directamente debajo del fusible mostrado en la esquina izquierda alto. Fije cable verde a este tierra.

Directores de circuito de attach en estas ubicaciones. Consulte la etiqueta mostrada para la identificación de fase.

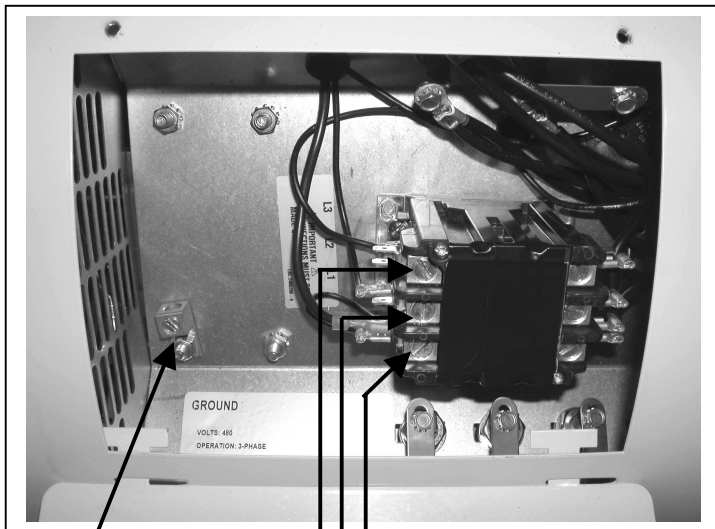

Modelos 3 fase

Fije alimentador cable o producto de cable a calentador tan mostrado en la fotografía en la izquierda para lo siguiente modelos 3 fase.

FES-1520-3A	YES-1520-3A
FES-1524-3E	YES-1524-3E
FES-1548-3E	YES-1548-3E
FES-1560-3A	YES-1560-3A
FES-3048-3A	YES-3048-3A
FES-3060-3A	YES-3060-3A

Tierra conductor
Fije cable verde a esta oreja tierra.

Fije a directores de circuito a las tierra sobre el contactor. Consulte la etiqueta mostrada para la identificación de fase.

Cableado (continuado)

FES & YES Diagramas de cableado 3 fase

FES-1524-3E YES-1524-3E

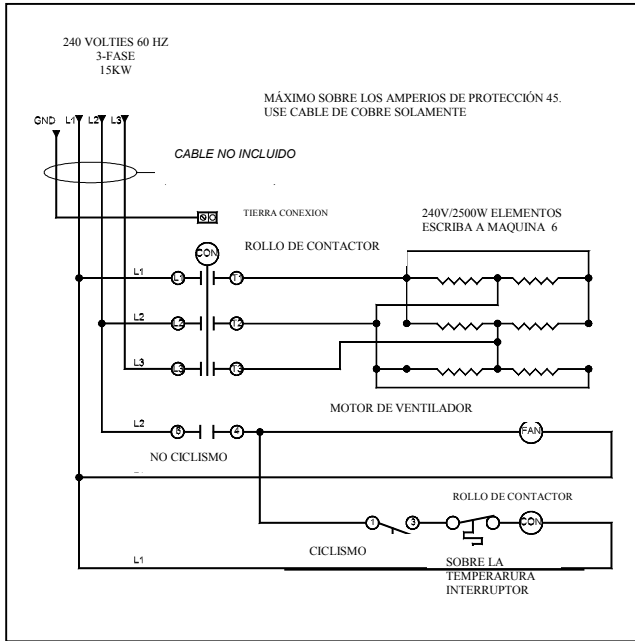

FES-1520-3A YES-1520-3A

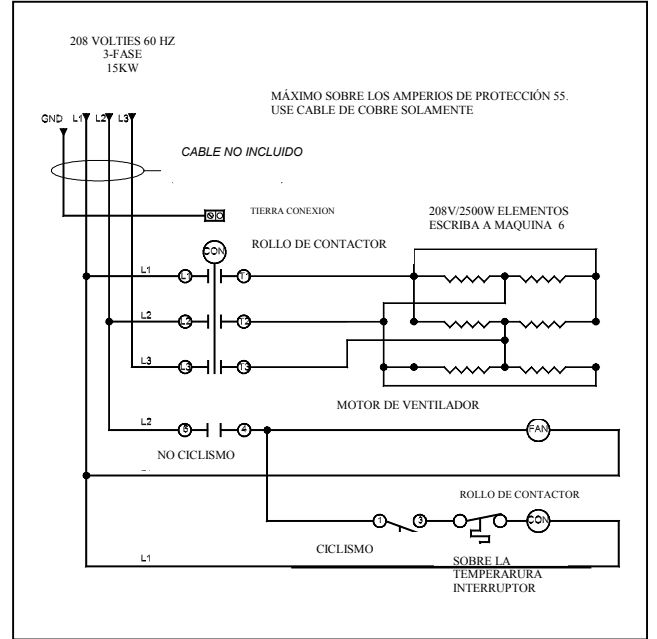

FES-1548-3E YES-1548-3E

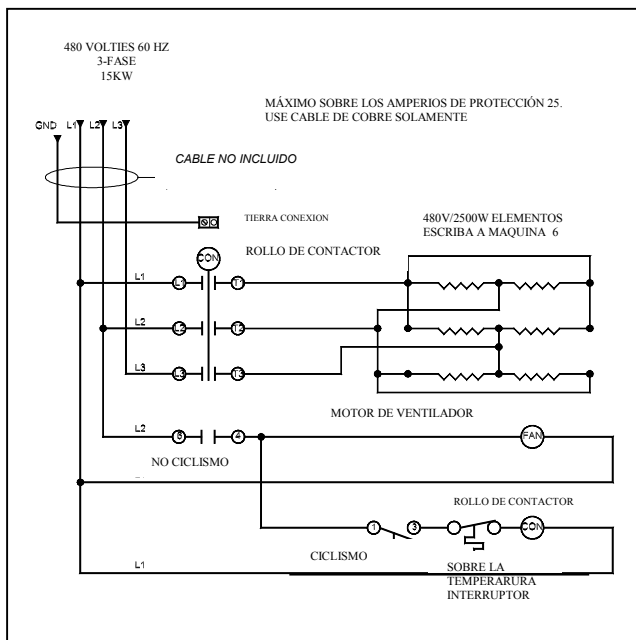

FES-1560-3A YES-1560-3A

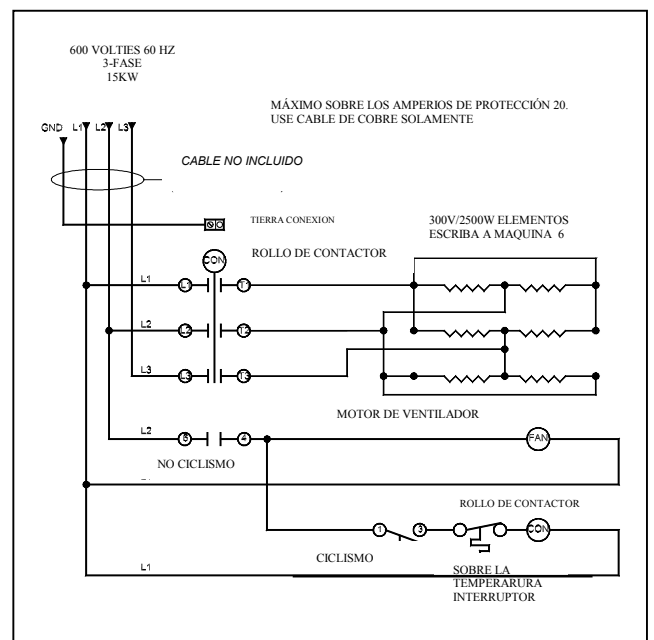

Cableado (continuado)

FES & YES Diagramas de cableado 3 fase

FES-3048-3A

YES-3048-3A

FES-3060-3A

YES-3060-3A

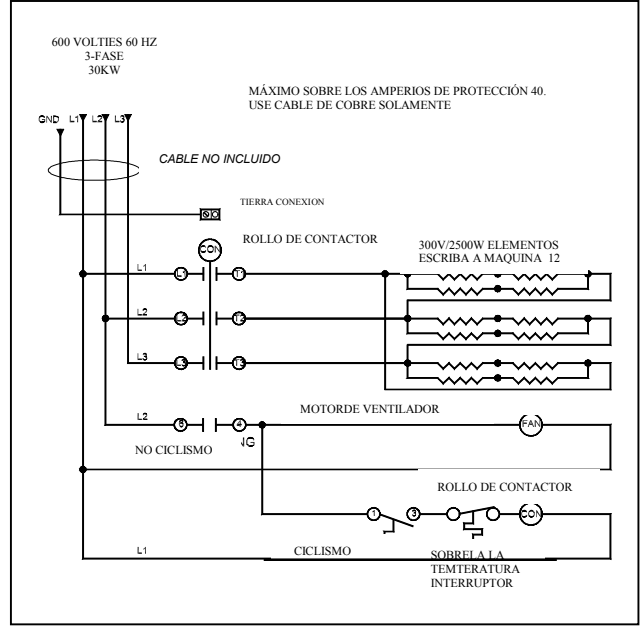
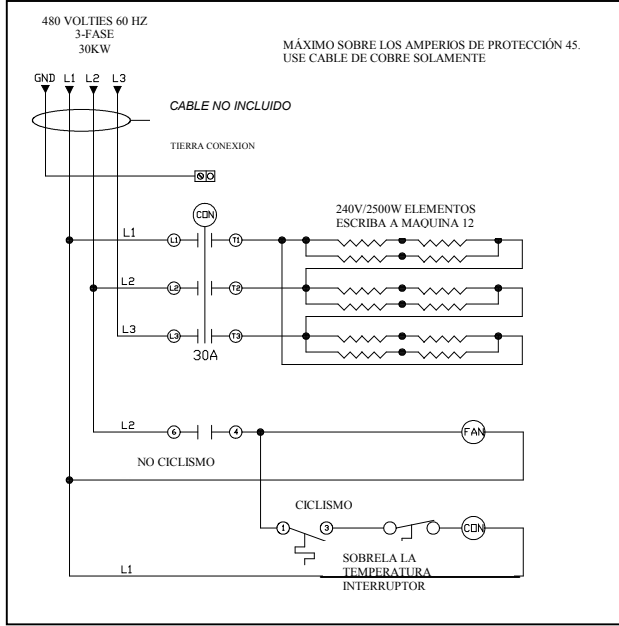

Operar las instrucciones

Fostoria FES y YES calentadores de serie son diseñados hacer circular aire de habitación al otro lado de sus elementos de calefacción para incrementar la temperatura de habitación gradualmente. Los mejores resultados de rendimiento serán obtenidos cuando usan estos calentadores en espacios más pequeños y limitados con techos bajos.

La operación de estos calentadores está consumada vía el uso de un termostato multi- función (enviar la diagrama abajo).

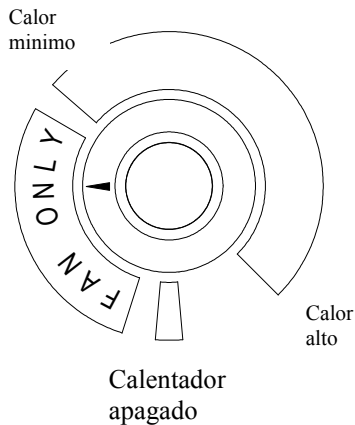

Usted tiene la alternativa de usar el ventilador solamente*, o el ventilador y los elementos de calefacción juntos. Coloque el puntero de pomo en la área "fan only" (ventilador solamente) de hacer circular aire de habitación sin calefacción. Cambie de lugar el puntero en la área de "Calor" de dar energía a los elementos de calefacción y prepare el termostato. La calefacción máxima es obtenida con pomo girado completamente en sentido de las agujas del reloj**.



El ventilador y los elementos son apagados cuando el pomo es girado completamente en sentido contrario a las agujas del reloj.

El ventilador debe operar durante minimum de 3 minutos cuando usted es termino para purgarse calor de unidad.

***El termostato tiene un fijó la gama de 40°F a 100°F. Si la temperatura ambiente del ambiente es abajo 40°F, no habrá "ventilador sólo" funciona como el termostato siempre llama para el calor.**

****La colocación que el termostato para calentar alto contra el calor bajo no hace el operar de la unidad en una temperatura más alta. Levanta simplemente la temperatura necesaria para satisfacer el termostato. La unidad correrá más largo tratar de satisfacer una colocación más alta de termostato.**

Nota: Todos modelos de FES / YES están equipados con un límite de temperatura de interior over diseñado proteger su calentador si una condición de corriente de aire restringida ocurre. Este dispositivo de límite cesacion de trabajo los elementos de calefacción totalmente si el límite de temperatura es llegado. El límite se reinicia cuando la unidad se enfría automáticamente.

  	! ADVERTENCIA
<p style="margin: 0;">EL PELIGRO DE FUEGO EL PELIGRO DE EXPLOSIÓN PELIGRO DE BURN</p> <ul style="list-style-type: none"> Perjuicio serio o muerte podrían ocurrir. Lea y siga el buzón de entrada de información de seguridad todos abajo. 	
<ul style="list-style-type: none"> Nunca uso fuera o donde los gases inflamables o líquidos son guardados. Nunca use como un consuelo residencial calentador. Guarde calentador portátil 3 ft. mínimo de todos materiales combustibles siempre. Nunca modifique calentador de alguna manera. Nunca suministre el poder a calentador cuando la unidad está cerca del agua parada. Solamente use asa para cambiar de lugar calentador. Nunca contacto vivienda de calentador mientras en uso. Nunca permita que el alimentador cable haga contacto con materiales combustibles. Purgue el calor de unidad después del uso siempre. Opere ventilador solamente durante 3 minutos. 	

Lista de partes de reemplazo de FES & vistas esquemáticas

RefNo.	Descripcion	1024-1CA	1520-3A	1524-3E	1548-3E	1560-3A	3048-3A	3060-3A
1	Motor	8482001 (1)	8482001 (1)	8482001 (1)	8482002 (1)	8482003 (1)	8482004 (1)	8482005 (1)
2	Carruaje de perno 1/2-13 x 2-3/4	2470132 (2)	2470132 (2)	2470132 (2)	2470132 (2)	2470132 (2)	2470132 (2)	2470132 (2)
3	Topa rotativa	8481223 (2)	8481223 (2)	8481223 (2)	8481223 (2)	8481223 (2)	8481223 (2)	8481223 (2)
4	Termostato	2470300 (1)	2470300 (1)	2470300 (1)	2470300 (1)	2470300 (1)	2470300 (1)	2470300 (1)
5	Arandela - no mostrado	-----	-----	-----	2485400 (2)	2485400 (2)	-----	-----
6	Termostato de pomo	2470500 (1)	2470500 (1)	2470500 (1)	2470500 (1)	2470500 (1)	2470500 (1)	2470500 (1)
7	Correa	2470800 (1)	2470800 (1)	2470800 (1)	2470800 (1)	2470800 (1)	2470800 (1)	2470800 (1)
8	Mortaja	8480910 (1)	8480910 (1)	8480910 (1)	8480910 (1)	8480910 (1)	8481110 (1)	8481110 (1)
9	Corchete de montura de motor	8480801 (1)	8480801 (1)	8480801 (1)	8480801 (1)	8480801 (1)	8480800 (1)	8480800 (1)
10	SEMS de 10 - 32x 5/16 de tornillo	2470932 (8)	2470932 (12)	2470932 (12)	2470932 (12)	2470932 (12)	2470932 (24)	2470932 (24)
11	Final de montura de motor	8480700 (2)	8480700 (2)	8480700 (2)	8480700 (2)	8480700 (2)	8480700 (2)	8480700 (2)
12	Arandela 9/16	3419500 (8)	3419500 (12)	3419500 (12)	3419500 (12)	3419500 (12)	3419500 (24)	3419500 (24)
13	Nuez 1/4 - 20 hexadecimal	3426000 (4)	3426000 (4)	3426000 (4)	3426000 (4)	3426000 (4)	3426000 (4)	3426000 (4)
14	Arandela 1/4	3427900 (8)	3427900 (8)	3427900 (8)	3427900 (8)	3427900 (8)	3427900 (8)	3427900 (8)
15	Parrilla	8480621 (2)	8480621 (2)	8480621 (2)	8480621 (2)	8480621 (2)	8480621 (2)	8480621 (2)
16	Arandela	2472032 (4)	2472032 (4)	2472032 (4)	2472032 (4)	2472032 (4)	2472032 (4)	2472032 (4)
17	8-18 de tornillo x 1/2	3444456	3444456	3444456	3444456	3444456	3444456	3444456
18	Contacto	8480402 (1)	8480402 (1)	8480400 (1)	8480401 (1)	8480403 (1)	8480401 (1)	8480403 (1)
19	Cable y enchufe - no mostrar	3171701 (1)	-----	-----	-----	-----	-----	-----
20	1/2 - 13 de nuez	3460200 (2)	3460200 (2)	3460200 (2)	3460200 (2)	3460200 (2)	3460200 (2)	3460200 (2)
21	3/4 de x de 1/4 - 20 de tornillo	3494156 (4)	3494156 (4)	3494156 (4)	3494156 (4)	3494156 (4)	3494156 (4)	3494156 (4)
22	Límite alto	3183900 (1)	3183900 (1)	3183900 (1)	3183900 (1)	3183900 (1)	41041001 (1)	41041001 (1)
23	Oreja de suelo	41254001 (1)	41254001 (1)	41254001 (1)	41254001 (1)	41254001 (1)	41254001 (1)	41254001 (1)
24	Conector	7714122 (1)	7714122 (1)	7714122 (1)	2485300 (1)	2485300 (1)	7714122 (1)	7714122 (1)
25	Baffle - no mostrado	8483800 (1)	8483800 (1)	8483800 (1)	8483800 (1)	8483800 (1)	8483800 (1)	8483800 (1)
26	Bussbar - no mostrar	8421600 (4)	8421600 (8)	8421600 (8)	8421600 (5)	8421600 (5)	8421600 (10)	8421600 (10)
27	Elemento interior	8481401 (2)	8481403 (3)	8481401 (3)	8481401 (3)	8481405 (3)	8481401 (6)	8481405 (6)
28	Elemento exterior	8481402 (2)	8481404 (3)	8481402 (3)	8481402 (3)	8481406 (3)	8481402 (6)	8481406 (6)
29	Admirador de hoja - no mostrado	8422300 (1)	8422300 (1)	8422300 (1)	8422300 (1)	8422300 (1)	8422300 (1)	8422300 (1)
30	Tapa	8481010 (1)	8481010 (1)	8481010 (1)	8481010 (1)	8481010 (1)	8481010 (1)	8481010 (1)

PARRILLA ANEXO

TERMOSTATO

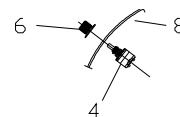
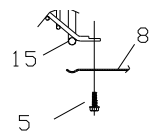

TOPA ROTATIVA

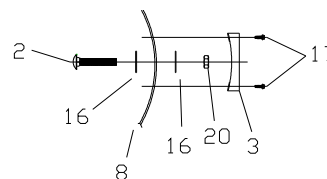

VEA THERMOSTATO DETALLE

VEA TOPA ROTATIVA DETALLE

VEA EL DETALLE DE ANEXO DE LA PARRILLA

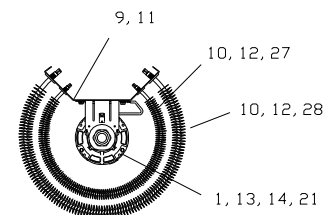
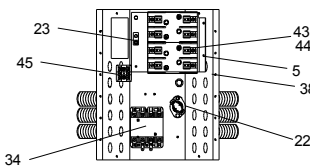
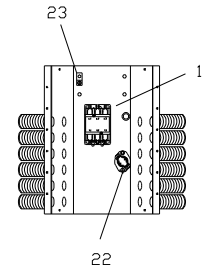
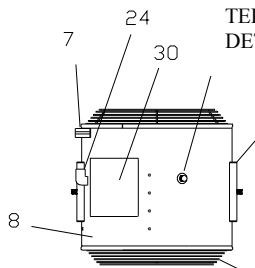

RefNo.	Descripcion	1524-1A
1	Motor	8482001 (1)
2	Carruaje de perno 1/2-13 x 2-3/4	2470132 (2)
3	Topa rotativa	8481223 (2)
4	Termostato	2470300 (1)
5	Arandela - no mostrado	-----
6	Termostato de pomo	2470500 (1)
7	Correa	2470800 (1)
8	Mortaja	8481810 (1)
9	Corchete de montura de motor	8480800 (1)
10	SEMS de 10 - 32x 5/16 de tornillo	2470932 (12)
11	Final de montura de motor	8480700 (2)
12	Arandela 9/16	3419500 (12)
13	Nuez 1/4 - 20 hexadecimal	3426000 (4)
14	Arandela 1/4	3427900 (10)
15	Parrilla	8480621 (2)
16	Arandela	2472032 (4)
17	8-18 de tornillo x 1/2	3444456
18	Contacto	8480406 (1)
19		
20	1/2 - 13 de nuez	3460200 (2)
21	3/4 de x de 1/4 - 20 de tornillo	3494156 (4)
22	Límite alto	3183900 (1)
23	Oreja de suelo	41254001 (1)
24	conector	7714122 (1)
25	Baffle - no mostrado	8483800 (1)
26	Bussbar - no mostrar	8421600 (8)
27	Elemento interior	8481401 (3)
28	Elemento exterior	8481402 (3)
29	Admirador de hoja - no mostrado	8422300 (1)
30	Tapa	8481010 (1)
31	Bloque de fusible de corchete	8481700 (1)
32	Bloque de fusible	8481600 (2)
33	250V de FLNR - 40 de tipo de fusible	71031471 (4)
34	Bloque final	51243002 (1)

FES Lista de partes de reemplazo & vistas esquemáticas

Referencia Numero	Descripción	Número de la pieza.
1	Asa	8480021
2	Arandela Parte plana ¼	3442532
3	Tornillo ¼-20 x 2-3/4	2470032
4	Parada de nuez ¼-20	3440132
5	Eje	8480232
6	Enchufe de gorra	3409200
7	Pierna	8480121
8	Arandela de goma	2480200
9	Separador	8480500
10	Arandela Parte plana ½	3460156
11	Rueda	8480300
12	Nuez de empujón	8045700
13	Pomo	2470200
14	Separador	2471932
15	Arandela Cerradura ¼	3427900
16	Tornillo ¼-20 x 1-3/4	2471832

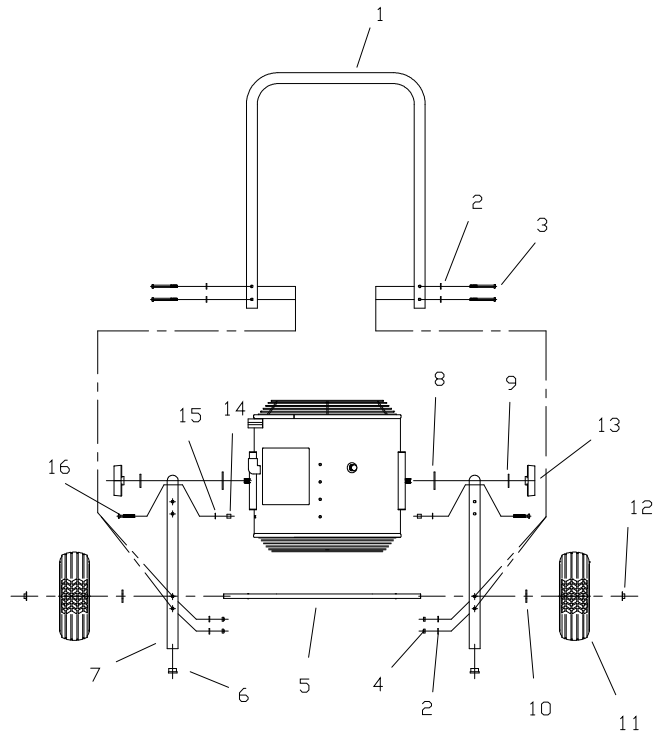

YES Lista de partes de reemplazo & vistas esquemáticas

Referencia Numero	Descripción	Número de la pieza.	Cantidad
1	Percha	8484023	1
2	Arandela de goma	2480200	2
3			
4	Pomo	2470200	2
5	Corchete en aumento	57074002	1
6	Guardabarros arandela	3472232	4
7	Arandela de nylon	3443700	1
8	Topa rotativa	8483923	1
9	½ - 13 de alto de nuez	3446432	1
10	½ - 13 x 1-1/2 de tornillo	2480132	1
11	Topa rotativa- Costado	8484423	2

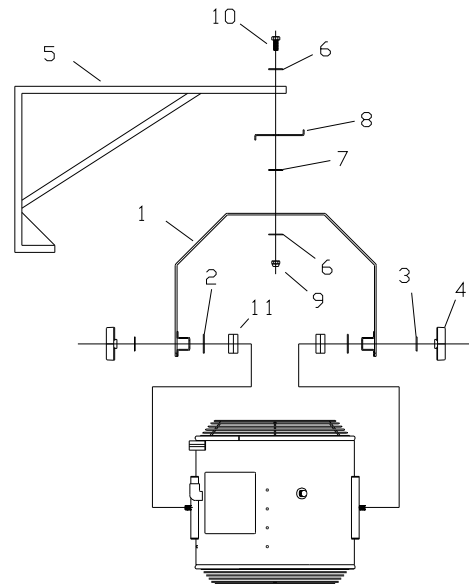

Cambiar una unidad de FES por una unidad de YES pida el p / n 04804102 de WMK - FES de modelo de paquete de Fostoria.

Mantenimiento

Aparte de periódico limpiando del exterior, ningún mantenimiento es requerido para estos calentadores.

- Nunca riegue estas unidades.
- Quite la suciedad desde el interior de calentador con aire comprimido.
- Nunca opere estos calentadores sin las parrillas o el compartimento de cableado la cobertura a término en su lugar.
- Reemplace o repare alimentador cable o cordón si daño visible es observado.
- Los cojinetes de motor son lubricados permanentemente.



ADVERTENCIA

PELIGRO DE CONMOCIÓN ELÉCTRICO

- **Perjuicio serio o muerte podrían ocurrir.**
- **Desconéctese del suministro eléctrico antes de atender o limpie estos calentadores.**
- **Nunca opere sin parrillas y tapas de acceso abrochadas en su lugar.**

Garantía limitada

FOSTORIA INDUSTRIES, INC. – 1200 North Main Street - Fostoria, Ohio 44830-1911 - (419) 435-9201

La garantía descrita en este documento está en vigencia en lugar de cualquier otra posible garantía, ya sea expresa o implícita.

Fostoria Industries, Inc. of Fostoria, Ohio 44830, garantiza sus productos al comprador contra cualquier defecto en los materiales y mano de obra durante un período de doce (12) meses en uso y servicio normal a partir de la fecha de fabricación o de instalación si se suministra prueba de la misma al vendedor.

Esta garantía requiere que el propietario, o un agente del mismo, instale el equipo de conformidad con el Reglamento Nacional de Instalaciones Eléctricas, con cualquier otro reglamento de electricidad o calefacción que corresponda, y con las instrucciones de instalación del fabricante. Asimismo, la garantía requiere que se proporcione mantenimiento a la unidad, según sea necesario y razonable. La compañía no es responsable del abuso y uso indebido a que se sujete la unidad, según lo determine en forma definitiva la compañía.

La obligación de Fostoria Industries, Inc., de conformidad con las estipulaciones de esta garantía, será suministrar una pieza nueva, reparar una pieza defectuosa, o remitir un reembolso, todas estas opciones a la sola y total discreción de la compañía, sin cargo al propietario, por la pieza nueva o reparación, según sea el caso. La pieza defectuosa debe devolverse a la fábrica o a cualquier otra parte, según lo indique la compañía. Esta garantía no obliga a Fostoria Industries, Inc. a cubrir el costo de la mano de obra para reemplazar ensambles, unidades o componentes, ni la compañía asume ninguna responsabilidad de cargos o gastos secundarios por concepto de la instalación o desmontaje, ni de ninguna pérdida derivada. La máxima responsabilidad de la compañía en ningún caso excederá el precio de lista del producto presentado como defectuoso.

La garantía no se aplica a ningún producto o pieza integrantes de un producto que haya sido reparada o alterada fuera de la fábrica en ninguna forma. La garantía se anula con respecto a todos aquellos productos que, a juicio de la compañía, hayan sido sujetos a abuso, negligencia o accidentes, o hayan sido empleados en una forma contraria a la indicada en las instrucciones del fabricante.