

EASYHEAT[®]

SELF-REGULATING PIPE TRACING HEATER CABLE

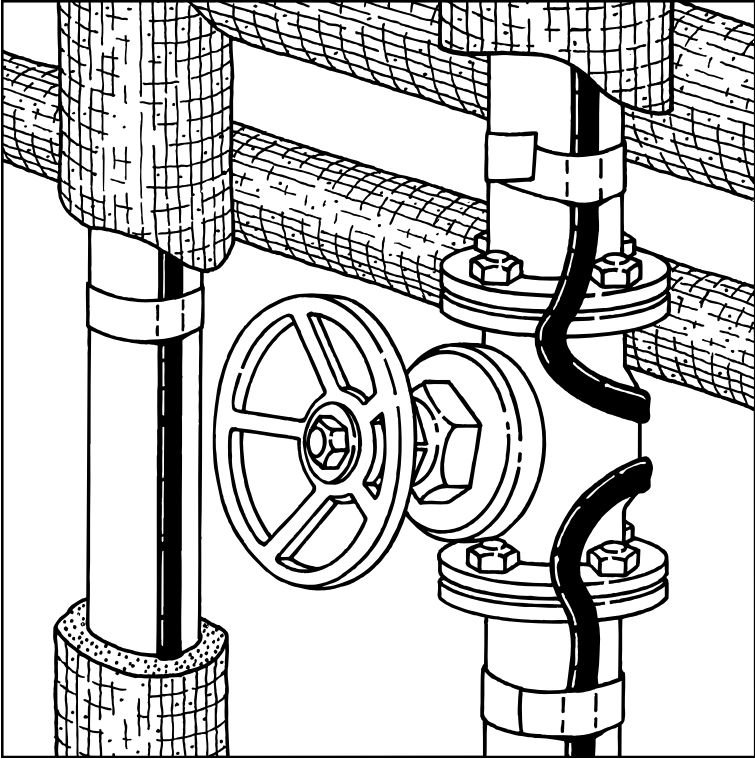

Installation & Operation Manual

TABLE OF CONTENTS

GENERAL INFORMATION	1
<i>How Heating Systems Work</i>	1
PRODUCT SELECTION	1
RECEIPT & STORAGE	1
<i>Receipt</i>	1
<i>Storage</i>	1
<i>Withdrawal from Storage</i>	1
INSTALLATION	2
Warnings	2
<i>Scheduling</i>	2
<i>Pre-Installation Check</i>	2
<i>Heater Handling</i>	2
<i>Heater Cable Placement on Pipe</i>	2
<i>Straight Tracing</i>	2
<i>Spiraling</i>	3
<i>Attachment</i>	4
<i>Cutting the Heater Cable</i>	5
<i>Installation Details</i>	5
Power Connections, Splices and Terminations	7
THERMAL INSULATION	7
<i>Pre-Installation Checks</i>	7
<i>Installation</i>	7
<i>Marking</i>	8
Thermostats & Sensors	8
Electrical Requirements	9
Voltage Rating	9
<i>Electrical Loading</i>	9
<i>Ground Fault Protection</i>	9
<i>Waterproofing</i>	9
Testing	9
<i>Recommendations</i>	9
<i>Procedure</i>	9
Periodic inspection record form	10 – 11
Start-up	12
Heat-up Time	12
Diversity Factor	12
OPERATION & MAINTENANCE	12
System Design, Installation & Documentation	12
Preventive Maintenance	12
Visual Inspections	12
Frequency	12
Personnel Training	12
Maintenance	12
Piping Repairs	13
Damaged products	13
TROUBLESHOOTING	14
Heat Trace Installation Record	15

GENERAL INFORMATION

This manual is designed for use with Easy Heat self-regulating pipe tracing heater cable products. Applications include freeze protection and temperature maintenance, including hot water supply. For applications not specifically addressed, please contact your local representative.

How Heating Systems Work

An electric heating cable system uses the electric heater cable to replace the heat that is lost through the thermal insulation system. Replacing the lost heat allows the pipe and fluid inside the pipe to be maintained at a constant temperature. This will keep water from freezing and bursting a pipe, or a liquid from setting up (congealing) and plugging the pipe. Simple systems may turn the entire system on with a contactor or switch, while others will use a thermostat with each heater cable to control the temperature.

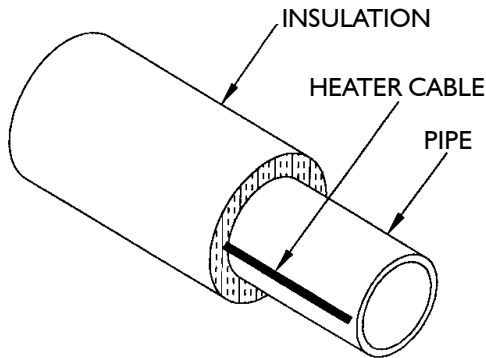

Figure 1

PRODUCT SELECTION

Check and verify that the proper heater cables are being installed on each pipe and vessel. If no design/installation documents exist, check the appropriate Easy Heat Heat Application Guide to determine the proper equipment for the application.

RECEIPT & STORAGE

Receipt

- Compare the materials against the shipping bill to verify receipt of proper materials.
- Inspect heating cable and components for transit damage. Insulation resistance tests on each spool of cable are recommended.
- If design documents (line lists or per circuit bills of material) exist, check the received materials against the lists to verify all needed materials. If no design documents exist, keep a receipt log of all materials received.

Storage

Cables and system components should be stored in a clean, dry area. The equipment should be protected from mechanical damage during storage. The storage temperature range is -40°F to 140°F (-40°C to 60°C).

Withdrawal from Storage

It is recommended that a check out record be kept (in conjunction with the receipt records) on equipment as it is removed from storage. This will serve to identify developing material shortages before they happen - since project additions often cause the use of material for other than designated piping.

INSTALLATION

Warnings!

While there are many acceptable ways of installing Easy Heat electric heating equipment, certain actions can be dangerous to personnel and your installations. Please take care to avoid the following problems:

- **DO NOT TWIST THE BUS WIRES TOGETHER AT EITHER END OF THE CABLE.** Each of these wires has either voltage or neutral applied to it; twisting them together will cause a short circuit.
- **INSULATE BLACK POLYMER SURROUNDING BUS WIRES.** The black compound extruded around the bus wires is electrically conductive and should be treated as a conductor. Follow connection kit installation instructions carefully.
- **ALL ELECTRICAL CONNECTIONS IN THE SYSTEM SHOULD BE SEALED AGAINST MOISTURE.** To prevent electrical arcing and fire hazard, all cable connections and electrical wiring connections should be sealed against moisture. This includes the use of proper cable sealing kits and the moisture proofing of all wire connections. Use only Easy Heat connection kits.
- **DO NOT EXPOSE HEATER CABLES TO TEMPERATURES ABOVE THEIR MAXIMUM RATINGS.** Higher temperatures can greatly shorten the life of a heater.
- **IMMEDIATELY REPLACE ANY DAMAGED HEATER CABLE OR COMPONENTS.** Failure to replace any damaged components (heater cable, components, or thermal insulation) will result in system failure.
- **CLASSIFIED AREAS (EXPLOSIVE DUST OR GAS) REQUIRE THE USE OF SPECIAL ELECTRICAL COMPONENTS.** Any area having explosive gases (such as chemical/petrochemical installations) or explosive dusts (such as coal handling or graineries) require special cable, connection components and control components that are approved for use in these areas. Installation of non-approved products can result in fires or explosions.
- **INSTALLATION ON PLASTIC PIPE REQUIRES SPECIAL CONSIDERATIONS IN SELECTION AND INSTALLATION.** Refer to cable Application Guide for details in design and selection.

Scheduling

The installation of the electric heat tracing must be coordinated with the piping, insulation, electrical and instrument installers. Cable installation should begin only after the majority of mechanical construction is complete. Pressure testing of the pipe and installation of the instruments should be complete prior to the start of the heater cable installation.

Pre-Installation Check

Walk the piping system and plan the routing of the heater cable. Use this check to verify completion of instrumentation and mechanical work. All coatings (paint, etc.) must be dry before attempting the heater cable installation.

Heater Handling

- Use a reel holder to roll out the heater cable.
- Keep the cable strung loosely, but close to the pipe being traced. This will avoid interference with supports and other equipment.
- Leave an extra 12-18" (305-457mm) of heater cable at all power connections, tee splices and end seal connections to facilitate easy completion of connections.
- **ADDITIONAL HEATER CABLE IS REQUIRED ON VALVES, PIPE SUPPORTS AND OTHER EQUIPMENT.** See the installation detail section for exact lengths and method of installation.
- When handling the heater cable, avoid pulling it over or installing against sharp edges.
- Do not kink or crush the cable, including walking on it or driving over it with equipment.

Heater Cable Placement on Pipe

The heating cable may be installed either straight along the pipe or spiraled around the pipe. Due to the increased labor and space requirements associated with spiraling cable on pipe, spiraling is not normally recommended. Spiraling does, however, enable the pipe heat loss to be very closely matched by the cable. Spiraling may thus reduce the amount of cable required on a pipe. Spiraling also limits the ability to service pipe system components. If spiraling is necessary, appropriate information is provided herein.

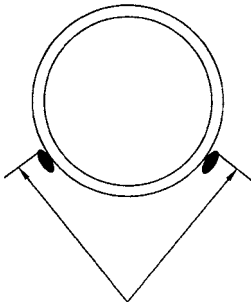

Figure 2

Install heating cable at
8 o'clock
or 4 o'clock
positions

Straight Tracing

When straight tracing is used, install the heater cable in the lower half of the pipe. This helps prevent physical damage to the heater cable from falling objects and being stepped on by service personnel.

Spiraling

Spiraling increases the length of heater cable installed per foot of pipe.

Installed cable length = Pipe Length X Spiral Factor.

The following example and table will allow you to determine the correct pitch for each pipe size and spiral factor:

Example: If 140' of cable are to be installed on 100' of 4" IPS pipe (spiral factor of 1.4), the Pitch (P) would be 356mm (14").

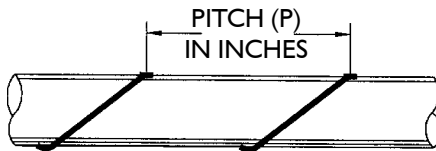

Figure 3

Table 1

Spiral Pitch Table (Inches)					
Pipe Size	Spiral Factor				
(IPS)	(feet of heater cable per foot of pipe)				
	1.1	1.2	1.3	1.4	1.5
1.0	NR	NR	NR	NR	NR
1.5	NR	NR	NR	NR	NR
2.0	17	NR	NR	NR	NR
2.5	20	14	NR	NR	NR
3.0	24	17	13	NR	NR
3.5	28	19	15	13	NR
4.0	31	21	17	14	NR
4.5	35	24	19	16	14
5.0	39	26	21	18	15
6.0	46	31	25	21	18
8.0	59	41	33	28	24

1 inch = 25mm

Attachment

For regular installations, the heater cable may be attached with fiberglass tape. Plastic wire ties may also be used, provided the plastic has a maximum temperature rating equal to or greater than the system requirements. The cable should fit snugly against the pipe and be secured at 305mm (12") intervals, as shown in Figure 5.

Figure 4

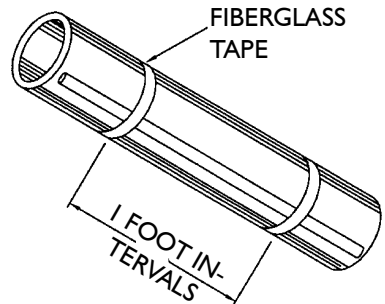
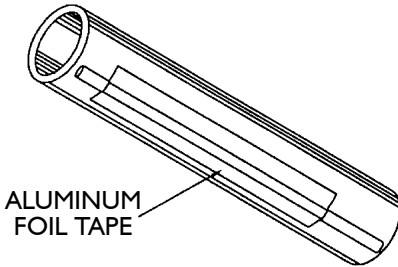

Figure 5

Notes

- 1) To prevent possible damage to the heater cable, do not fasten with metal straps, wire, vinyl electrical tape or duct tape.
- 2) Aluminum foil tape should only be used if specified by design. The foil is most often used on plastic pipe to offset the insulation effect of the plastic. See the Easy Heat Pipe Tracing Systems' Design Guide for details.

Cutting the Heater Cable

Do not cut the cable until it is attached to the pipe. Confirm the allowances for terminations, connections and heat sinks (valves, support, etc.) before cutting the cable. Heater cable power is not affected by cutting to length. Protect all heater cable ends from moisture or mechanical damage if exposed for long periods of time.

Installation Details

Heater cables should be applied in a manner to facilitate cable servicing and the easy removal of valves and small in-line devices without the need to remove excessive thermal insulation or having to cut the heater cable. The best way to accomplish this is to loop the cable in the area of power connections, splices and piping devices. See diagram. The amount of heater cable installed on each valve, hanger, etc. varies with the pipe size and type of device. Table 2 gives the correct additional cable to be installed on each device.

Table 2—Extra Cable at Devices, Feet

Pipe Size (in)	PIPE FITTING TYPE				
	Flange Pair	Vent & Drain	Pipe Support	Globe, Ball & Butterfly Valves	Gate Valve
.50	.30	1.0	1.0	1.0	1.0
.75	.30	1.0	1.5	1.0	1.5
1.00	.30	1.0	1.5	1.0	2.0
1.50	.30	1.0	2.0	1.5	2.5
2.00	.30	1.0	2.0	2.0	2.5
3.00	.30	1.0	2.0	2.5	3.0
4.00	.50	1.0	2.5	3.0	4.0
6.00	.80	1.0	2.5	3.5	5.0
8.00	.80	1.0	2.5	4.0	7.0
10.00	.80	1.0	3.0	4.5	8.0
12.00	.80	1.0	3.0	5.0	9.0
14.00	1.0	1.0	3.0	5.5	10.0
16.00	1.0	1.0	3.5	6.0	11.0
18.00	1.0	1.0	3.5	7.0	12.0
20.00	1.0	1.0	3.5	7.5	13.0
24.00	1.0	1.0	4.0	8.0	15.0

Notes

- 1) Nominal cable length in feet. Extra cable is minimum required for various in-line pipe fittings to compensate for greater areas of heat loss and to allow servicing of device.
- 2) Values above are based on area average of various fittings available, with the assumption that fitting insulation will be equivalent to pipe insulation. The nominal length of tracer to be applied to a particular fitting would be the value shown in this chart plus the flange-to-flange length of the fitting.
- 3) For a Flanged Valve Adder choose Valve Type then add one Flange Pair for total adder length.

The following figures show installation details for various typical situations:

Figure 6

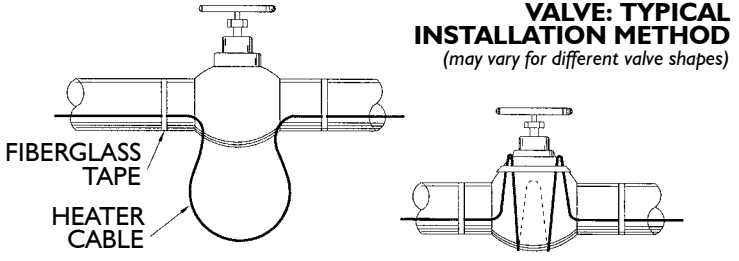

Figure 7

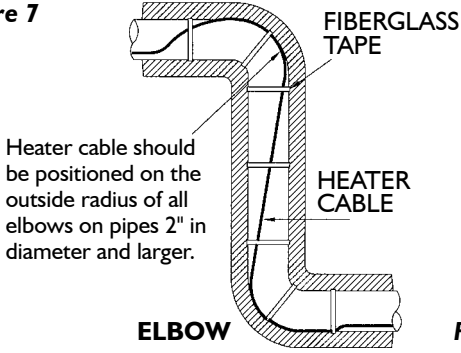

Figure 8

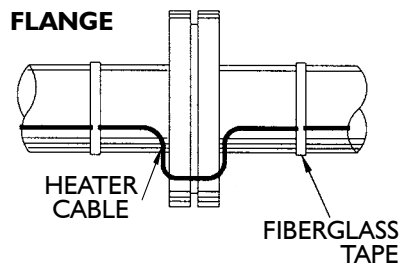

Figure 9

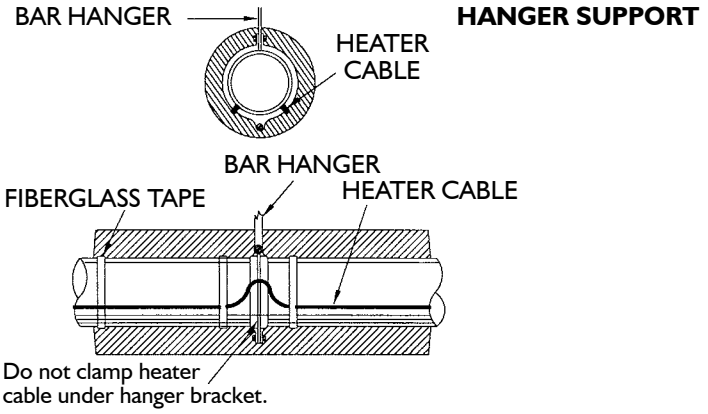
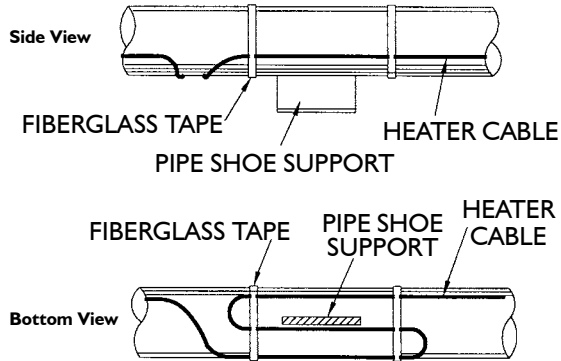

Figure 10
SHOE SUPPORT



Power connections, splices and terminations

Only Easy Heat approved termination, connection and splice kits may be used. Failure to do so will void warranties and agency approvals. Installation instructions in each component kit must be followed regarding heater cable preparation and assembly. Make end seals (terminations) and splice connections before making the power connections. It is recommended that all heater cables be labeled as they are installed with a discrete circuit number. This will facilitate identification, components needed and electrical wiring during later phases of the installation. Power connection kits utilize an adapter plate kit for installation on instrument tubing and tanks. Installation instructions for mounting are included in each kit.

Figure 11

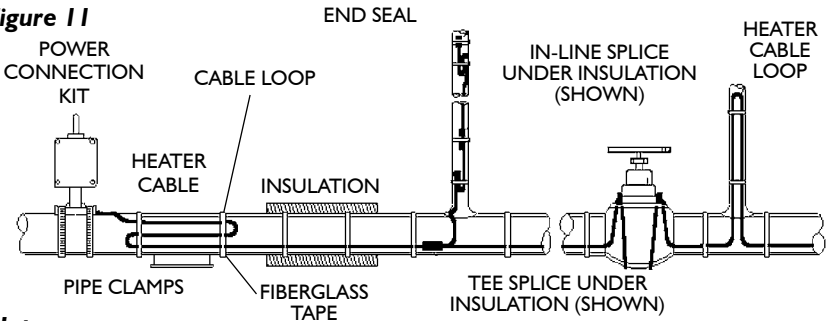

Note

Heater cable power connections and end seals are required for each heater cable. Heater cable splices, tees, and thermostats are used as needed.

THERMAL INSULATION

Pre-Installation Checks

Inspect the heater cable and components for correct installation and possible damage. In particular, verify that:

- The proper extra amount of heater cable has been installed at each valve, flange, pipe support, etc. and that all cables are free from physical nicks, tears or gouging.
- Connections, splices and end seals are correctly installed, including cable seals at power connection enclosures.

Installation

Check the thermal insulation type and thickness against the design criteria. Changes in insulation type or thickness may require a different wattage heater cable. Verify that all pipe work, including wall penetrations, fittings, etc. has been completely insulated.

Check the system to verify that:

- Insulation is not wet from rainfall or other moisture sources prior to the application of waterproofing.
- Lap joints on vertical piping are properly overlapped—higher piece lapped over the top of lower piece.
- Band seals are used at lap joints to prevent the ingress of water.
- All penetrations of lagging (valve stems, hanger rods, etc.) are properly water proofed.
- Irregular shaped items (i.e. pumps, etc.) are properly waterproofed.

To minimize potential damage to the heater cable, install the insulation as soon as possible. It is recommended that another insulation resistance (megger) test be done after the insulation has been installed to verify that the heater cable was not damaged during the insulation installation.

Marking

Install “Electric Trace” signs on alternate sides of the piping at regular intervals, as a warning to maintenance personnel. Permanently mark the outside of the insulation lagging with the location of heater cable components. This will facilitate any future servicing requirements.

Thermostats & Sensors

Temperature sensitive applications will require the use of a thermostatic control. Selection of the proper thermostat must consider voltage and amperage ratings of the device as well as the suitability of housing for the environment (explosion proof, rain tight, corrosion resistance, etc.). Thermostat sensor bulb must be attached to the pipe at a location representative of the entire length of pipe being protected by heating cable. If possible, thermostat housing should be mounted as close as possible to the power connection kit. It may be attached to the power connection kit provided code requirements are met with regard to conduit connections seals, etc. To sense the coolest air temperature, ambient (air sensing) thermostats should be mounted in the shade when possible. When using pipe-sensing thermostats, the bulb (sensor) should be mounted on the opposite side of the pipe from the heater, or at least 90° away from cable. This will allow the thermostat to sense the actual pipe temperature and not be influenced by the heater temperature. Mount the bulb at least three (3) feet from the closest heat sink if possible.

Moisture inside thermostat enclosure will cause both corrosion and electrical shorting problems. The potential for this type of problem, can be greatly reduced by:

- Proper sealing of all enclosure openings.
- Keeping enclosure cover closed and secured as much as possible during installation sequence
- Proper closing and sealing of the cover to prevent leaking into the housing.
- Use of a moisture proofing/electrical spray (aerosol) sealant on thermostat and electrical connections (including all metal parts) at completion of installation.
- Connection and use of space heater if thermostat is so equipped. **Do not de-energize space heater during summer months.**

Electrical Requirements

Voltage Rating

Verify that the heater cable voltage rating is suitable for the service being used. Refer to Easy Heat Application Guide if further information is required.

Electrical Loading

Size over-current protective devices according to Easy Heat Application Guide. If devices are other than standard thermal magnetic circuit breakers, consult Easy Heat.

Ground Fault Protection

Ground fault circuit breakers are required on all heater constructions per the National Electric Code. Typically, 30mA trip devices are required due to the capacitive leakage of the heater cable construction. Devices with lower trip levels can result in nuisance tripping. Consult Easy Heat for further information.

Waterproofing

Moisture penetration of the electrical system is the single largest source of problems in a heater cable system installation. Therefore, particular care must be given to the proper sealing of all electrical connections and splices. Heater cable connection kits will provide a proper seal for the heater cable itself, when installed as per kit instructions. All other electrical connections (power wiring, thermostat connections, panel and breaker connections, etc.) must be sealed or moisture proofed appropriately. Either mastic shrink tube or an aerosol electrical insulative sealant should be used on all connections to reduce any moisture penetration. The sealant will also reduce the potential for corrosion on exposed metal parts.

Testing

Recommendations

Electrical tests are recommended at specific points in the receipt and installation of the heater cable. This periodical testing is designed to provide early warning in the event of damage to the heater cable during installation. Installation costs of the cable and thermal insulation can be significant. Early identification of any heater cable damage is the most economic approach to an installation. An insulation resistance test is recommended at the following point of the installation process:

- UPON RECEIPT of the heater cable
- BEFORE thermal INSULATION installation
- IMMEDIATELY AFTER thermal insulation installation
- As part of a PERIODIC MAINTENANCE program

Procedure

The insulation resistance test is used to check for damage to extruded jackets. Connections for the megger are made as shown in Figures 12 & 13.

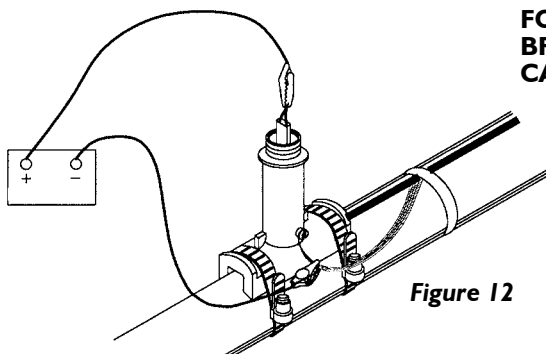

FOR HEATER CABLES WITH BRAID, TEST FROM HEATING CABLE BUS TO BRAID

Note

Test should use at least a 500 VDC megger. Do not use a megger with an excess of 2500 VDC. Minimum acceptable readings should be 20 megohms per circuit, regardless of length.

Figure 12

Figure 13

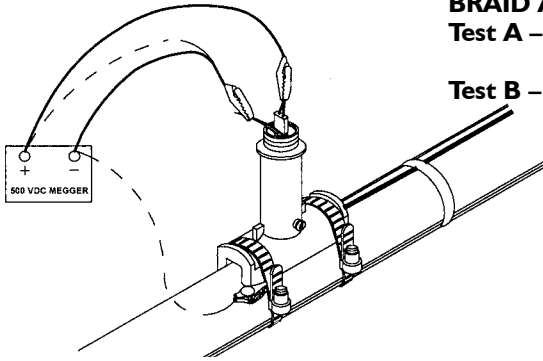

FOR HEATER CABLES WITH BRAID AND OUTER JACKET

Test A – From heating cable bus
wires to braid

Test B – From braid to metal pipe

A record should be kept of the readings taken from the time the cable is first installed on the pipe. A history of the insulation resistance reading can be helpful in spotting moisture ingress into the electrical system (by seeing a gradual decline in the insulation resistance or physical damage to the heater cable (sharp decline in the insulation resistance). A sample record for this is shown in Figure 14.

Periodic Inspection Record Form

The Periodic Inspection Record Form may be used in one of two ways:

- 1) **One sheet per circuit.** The results of periodic tests of a single circuit are posted in vertical columns, beginning on the left and working toward the right. This allows easy comparison of test values for up to seven test sequences on an individual circuit.
- 2) **One circuit per column.** Test data for a single test sequence on as many as seven circuits can be recorded on a single sheet.

EASYHEAT[®]

Circuit Number
Heater Type
Circuit Length

Periodic Inspection Record

Freeze Protection Circuits

Perform these checks as season requiring use approaches.

Temperature Maintenance Controls

Perform these checks at least twice per year.

Maintenance Checks for _____	Month _____	Year _____						
Visual inspection inside connection box corrosion, moisture, etc.	Initial							
	Date							
Damage or cracks (leaks) in insulation seals at valves, hangers, pumps, etc.	Initial							
	Date							
Heater cable properly connected and grounded. Heater cable and connections insulated from connection box.	Initial							
	Date							
Thermostat checked for moisture, corrosion, set point, switch operation, and capillary damage.	Set Point							
	Initial							
Megger tests performed at power connection with both bus wires disconnected from power wiring	Reading							
	Initial							
Date	Date							
Circuit voltage at power connection.	Reading							
Circuit amperage after 5 minutes.	Reading							
Pipe temperature at time amps were measured.	Reading							
Watts/Ft.								
$\frac{\text{Volts} \times \text{Amps}}{\text{feet}} = \text{w/ft.}$	Initial							
	Date							
All connections, boxes, and thermostats have been resealed.	Initial							
	Date							
End seals, covered splices and tees marked on insulation cladding.	Initial							
	Date							

Remarks & Comments								

Figure 14
Periodic Inspection Record Form

Start-up

Heat-up Time

Heat-up capacity (the ability to heat the pipe and its contents rapidly) is not normally designed into the system. Cold start-ups should allow adequate time for the pipe to come up to temperature.

Diversity Factor

If the electrical supply capability is limited, then a diversity factor may be used in a cold start situation (trying to start the entire system up in very cold weather). This is accomplished by staggering the initial turn on of the various heater cable circuits such that the inrush currents occur in a sequential fashion rather than all at once.

OPERATION & MAINTENANCE

System Design, Installation & Documentation

The heater cable system must be properly designed, installed and documented. This documentation should at least include line lists and location identification documentation. As built installation drawings provide the optimum maintenance tool. Test records should also be considered as part of the system documentation requirements. See Figure 15.

Preventive Maintenance

A preventive maintenance program is needed which will encompass both visual and electrical checks of the system. These should be done not only before initial operation of the system, but also on a scheduled basis. The checks should also be done after any maintenance has been performed.

Visual Inspections

- Thermal insulation. Check weatherproofing for damage, missing seals, cracks or gaps in caulking and mastic coatings, damaged or missing lagging. When damage does exist, the insulation will need to be repaired or replaced, and then resealed. **WET INSULATION HAS POOR INSULATING PROPERTIES, THEREFORE THE INSULATION MUST BE KEPT DRY.** If insulation has been damaged, check the heater cable for damage—replace any damaged sections.
- Inspect junction boxes, connection boxes and thermostats for corrosion, moisture or foreign matter.
- Tightness of electrical connections, proper electrical insulation of heater cable wires, adequacy of moisture seal on electrical connections and that a minimum of one (1) inch of electrically insulated heater extends above the grounding connection. No strands of the ground braid should extend above this connection.
- Check all thermostats or sensor capillary leads to verify they are tied back and shielded from physical damage.
- Verify all enclosure, connection box, etc. covers are properly closed and that the thermostat is switching off and on by measuring current flow in the circuit when the unit switches on. Reset the knob to the proper temperature after completion of the test.

Frequency

Inspections should be made prior to the start of the freeze season on freeze protection systems. Process maintenance systems should be checked on a frequent base, at least twice a year.

Personnel Training

Qualified maintenance personnel must maintain the system. It is recommended that periodic training programs be utilized to assist in keeping maintenance personnel up to date on equipment and procedures.

Maintenance

The heater cables will not require any maintenance. Mechanical temperature controls should be sprayed with a moisture repellent/corrosion inhibitor once a year on all metal parts.

Piping Repairs

Disconnect the electrical connection for the heater cable and protect it from mechanical or thermal damage during the repair. Check the heater cable installation after the repairs per established procedures. Replace and water seal the thermal insulation system.

Damaged products

Do not attempt to repair a damaged heater cable; replace the entire section. Fault currents will often destroy the connection between the bus wires and the heater core material from the fault location to the power supply end of the circuit.

Replace the damaged heater cable immediately. If cable core is left exposed, moisture migration into the undamaged section of the heater cable may cause electrical shorting in that cable after repair of the damaged section.

Any heater cable exposed to flame should be removed from service immediately and replaced. Further fire damage could result if energized.

Troubleshooting

SYMPTOMS	PROBABLE CAUSE	CORRECTION
A. Circuit Breaker Trips (Standard)	1. Circuit breaker undersized. 2. Circuit oversized. 3. Start-up at too low temp. 4. Defective circuit breaker. 5. Connection and/or splices may be shorting out. 6. Physical damage to the heater cable may be causing a short. 7. Wires connected at end seal.	1, 2, 3. Re-establish what the current loads are going to be and resize the breakers.* 4. Replace circuit breaker. 5, 6. Locate and repair incorrect connections, splices, or damaged sections of heater cable.** Megger per installation instructions. 7. Disconnect wires and perform a current check for possible other damage.
B. Circuit Breaker Trips (Ground Leakage Type)	1. All of section A. 2. Excessive moisture in connection boxes or splices. This can usually be verified by Megger test. 3. Nick or cut in heater or power feed wire with moisture present.	1. All of section A. 2. Dry out and re-seal connections and splices. Megger per Installation Instructions (20 megohms min.). Work on connections outside the thermal insulation first, going to the below insulation connections and seals after the others have been eliminated. 3. Locate and repair or replace damaged heater cable or power wire.**

* Check to see if existing power wire sizing is compatible with larger sized breakers.

** To locate shorting problems, follow these steps:

- 1) Visually inspect the power connections and splices that are outside of the thermal insulation for proper installation.
- 2) Check around the valves, pumps, and any area where there may have been maintenance work done, for visual indications of damage.
- 3) Look for crushed or damaged insulation lagging along the pipe.
- 4) Inspect heater cable splices under the thermal insulation.
- 5) If you have not located the problem by now, you will have to isolate one section of the heater cable at a time until you determine the general area of damage. First, isolate by disconnecting any tees or splices then remove insulation from that area until the specific damage is found. For long runs of cable, it may be necessary to cut the cable in half to isolate the shorted section.

Troubleshooting

SYMPTOMS	PROBABLE CAUSE	CORRECTION
<p>C. Power output is zero or lower than rated.***</p>	<ol style="list-style-type: none"> 1. Low or no input voltage. 2. Circuit is shorter than design length. <ol style="list-style-type: none"> a. splices or tees may not have been connected. b. Heater cable may have been severed. 3. Improper crimping causing a high resistance connection. 4. Control thermostat is wired in the opened position. 5. Pipe is at an elevated temp. 6. Heater cable has been exposed to excessive moisture. 7. Heater cable has been exposed to excessive temperatures. 	<ol style="list-style-type: none"> 1. Repair electrical supply lines equipment. 2. Check routing and length of heater cable (use "as built"), and recalculate power requirements. <ol style="list-style-type: none"> a. connect and recheck the power. b. Locate and repair the damaged heater cable. Recheck the power. 3. Re-crimp using correct procedure. 4. Rewire in the normally closed position. 5. Check pipe temperature and recalculate the output.*** 6, 7. Replace the heater cable.
<p>D. Power output appears correct but pipe temps. are below design value.</p>	<ol style="list-style-type: none"> 1. Insulation is wet. 2. Insufficient heater cable was used on valves, supports, and other heat sinks. 3. Thermostat was set incorrectly. 4. There are thermal design inconsistencies. 	<ol style="list-style-type: none"> 1. Remove and replace with dry insulation and insure proper weatherproofing. 2. Splice in additional heater cable but do not go over maximum circuit length. 3. Reset the thermostat. 4. Check with the local or factory representatives for design conditions. Modify as recommended.

*** The power output on lower resistance heater cables is temperature sensitive and requires a special procedure to determine its value.

- 1) Check the pipe temperature under the thermal insulation.
- 2) Allow heater cable to stabilize for 10 minutes and then measure the current.
- 3) Calculate the power (watts/ft) of the heater cable by multiplying the current by the input voltage and dividing by the actual circuit length, $I \times V / Ft = \text{Watts/Ft}$.
- 4) Compare the measured value to the power output curves for the heater cable at the measured pipe temperature. If the heater cable's actual output is substantially below the theoretical output, the bus wire interface with the core has been damaged by the fault current and the cable must be replaced. This is not a highly accurate method of analysis, so use discretion in comparing theoretical and actual values.

Heat Trace Installation Record

1. **Circuit No.** _____

2. **Receiving Documentation** Date _____

Item	DESIGN	ACTUAL
A. Cable Type	_____	_____
B. Cable Length	_____	_____

3. **Receiving Testing** Date _____

A. Check for physical damage.

O.K. _____ Damage _____

B. Continuity Check

Check for continuity between power leads.

O.K. _____ Damage _____

C. 500VDC min., 2500 VDC recommended, megger
check between leads and sheath, 20 megohms min.

Megohms _____

D. Lot No. _____ No. _____

4. **Post Installation Testing** Date _____

A. Check for continuity between cold leads.

O.K. _____ Open _____

B. 500VDC min., 2500 VDC recommended, megger
check between leads and sheath, 20 megohms min.

Check for continuity between power leads.

O.K. _____ Damage _____

C. Visually Check Cable Installation Prior to Release
for Thermal Insulation.

Megohms _____

D. Lot No. _____ No. _____

5. **Final Testing & Commissioning** Date _____

A. Circuit approved for testing by client.

Approved _____

B. 500VDC min., 2500 VDC recommended, megger
check between leads and sheath, 20 megohms min.

Megohms _____

C. Energized Testing **DESIGN** **ACTUAL**

(All test data to be within 10% of design data)

1. Circuit Voltage	_____	_____
2. Initial Current	_____	_____
3. Current after 15 mins. of operation	_____	_____
4. Current after 30 mins. of operation	_____	_____
5. Pipe temperature	_____	_____

6. **Circuit Acceptance**

This circuit has been tested and documented in accordance with the above itemized data. This circuit by:

Contractor _____

Date _____

Client _____

Date _____

Figure 15

The **Heat Trace Installation Record** can be used to monitor the initial installation and check-out process. This form can be used in conjunction with the **Periodic Inspection Record Form** shown in **Figure 14**.



USA

2 Connecticut South Drive
East Granby CT 06026

TEL 800/537-4732
FAX 888/324-2440

Canada

99 Union Street
Elmira ON N3B 3L7

TEL 519/669-2444
FAX 519/669-6419

www.easyheat.com