

# QUICK-REFERENCE INSTALLATION GUIDE



## TRACON<sup>®</sup> MODEL FPT-130

SINGLE-POINT FREEZE PROTECTION HEAT-TRACE CONTROL

### PACKING LIST

QTY.	PART NO.	DESCRIPTION
1	25169	TRACON MODEL FPT 130 Single-Point Freeze Protection Heat-Trace Control
1	25076	Temperature Sensor
1	25298	FPT 130 Installation Sheet (this document)
1	25165	FPT 130 Installation and Operation Manual

### PRIOR TO INSTALLATION

1. Read these installation instructions and manual prior to beginning installation.
2. Install this device only if you are a qualified electrician trained to perform such work.
3. Before beginning installation, lay out the system components, the heat trace cable and the temperature probe in their approximate locations to visualize the system and evaluate exact component and junction box placement, as well as required cable and conduit lengths.

### INSTALLATION

The FPT 130 Automatic Heat-Trace Control should be installed by a qualified, licensed electrician. Installation must conform to all applicable local and national electrical codes and laws. The unit's NEMA 4X IP66 enclosure allows for indoor or outdoor applications.

The FPT 130 controller has an ambient operating temperature range of -40 °F to 131 °F (-40 °C to 55 °C). To avoid potential internal condensation mount the unit out of direct sunlight.

Install the FPT on a fixed, flat, vertical surface using the unit's mounting flanges. The mounting flanges accommodate 1/4" or 6.3 mm fasteners.

The FPT 130's nonmetallic enclosure has one 1.046" hole for conduit entry; this can hold both power and load wiring.

Use only Listed Type 4X IP66 liquid-tight conduit hubs or cable glands. Connect the hub to the conduit system before connecting the hub to the enclosure.

The unit comes with two installed liquid-tight cable glands. One of these fittings is for the temperature sensor cable, and the other is for the alarm relay cable.

The cable glands can accommodate cable diameters 0.08" to 0.24" (2 mm to 6 mm). The temperature sensor may be located up to 2,000' (610m) from the FPT.

There is a removable electrical insulation divider that must be in place when there is power applied to the unit. All leads should be terminated; no unsecured leads should be left inside the wiring compartment.

# QUICK-REFERENCE INSTALLATION GUIDE

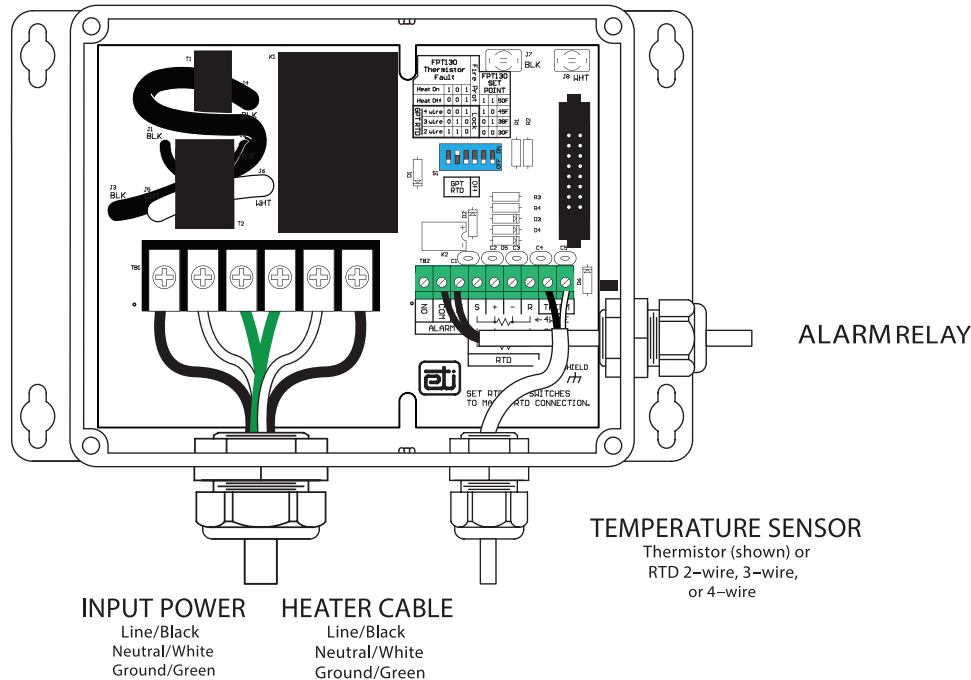

FIGURE 1. The FPT 130 wiring layout.

## NOTE:

Perform the following steps with the circuit breaker to the unit OFF. The TRACON FPT 130 is permanently connected equipment and does not have an internal disconnect device. When power is applied, the system will start.

### 1. INSTALL THE CONTROL BOX

Use the box itself as a template to determine the mounting hole footprint. Install the box to a solid, stable surface capable of supporting four times the weight of the box, or about 20 pounds. Use all four mounting holes. Install the control box to the wall using heavy-duty 1/4" or 6.3 mm fasteners long enough to fasten the box securely. Do not fully tighten mounting hardware at this time. Leave the mounting hardware loose enough to work the conduit into place. Hardware will be fully tightened following installation of the conduit.

### 2. CONNECT THE SUPPLY AND LOAD

Feed the Input Supply (Input Power) and the Load (Heater Cable) through the Conduit Entry Hole in the enclosure as shown, then connect the leads, as shown in the Figure 3. Line is black; neutral is white; ground is green.

**Note:** Both the power and the load require a #10 AWG wire.

### 3. INSTALL THE TEMPERATURE SENSOR

The FPT 130 comes with a thermistor temperature sensor with a 20 ft. jacketed cable that has an operating range of -40 °F to 230 °F (-40 °C to 110 °C). Refer to Figure 4.

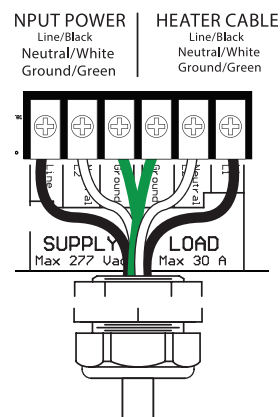

FIGURE 3. Contractor connections.

# QUICK-REFERENCE INSTALLATION GUIDE

## 4. INSTALL THE EXTERNAL ALARM

An alarm or power-off condition can be communicated by either opening or closing a relay contact. It is important to make the proper alarm relay connections to achieve the desired result. The middle terminal labeled COM (Common) is used in both wiring configurations. Connect one alarm relay lead to the COM terminal. If the system needs a contact to close to signal an alarm or power-off condition, connect the other alarm relay lead to the NC (Normally Closed) terminal.

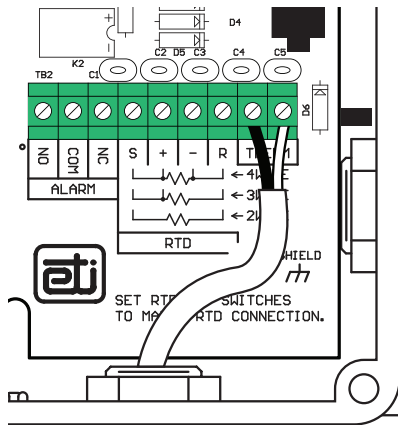

FIGURE 4. Thermistor sensor connection

Note: At this point the circuit breaker to the unit can be turned on providing power to the unit.

## 6. SETUP AND SETTINGS EDITING

Please refer to the FPT 130 Manual for comprehensive instructions for Setup and Settings Editing.

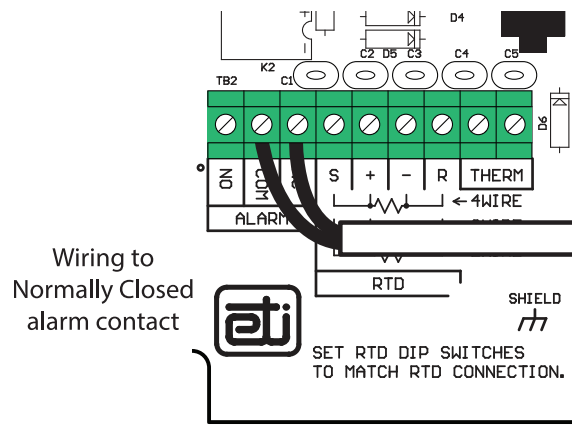

FIGURE 5. External alarm connection

If the system needs a contact to open to signal an alarm or power-off condition, then connect the other alarm relay lead to the NO (Normally Open) terminal.

If the unit has power, and there are no alarm conditions then the NO and COM terminals will be connected. If the unit loses power or an alarm condition occurs then the NC and COM terminals will be connected. Refer to Figure 5.

## 5. INSTALL THE CONDUIT AND FULLY TIGHTEN HARDWARE

Install the conduit runs to the control box. Use only Listed Type 4X IP66 liquid-tight conduit hubs. With cabling routed through conduit and conduit is secure, fully tighten the control box mounting hardware and re-assemble control box panels and cover in their original location.

Pilot Duty

# QUICK-REFERENCE INSTALLATION GUIDE



The FPT 130 Automatic Heat-Trace Control with GFEP cannot be used for Pilot Duty applications.

## Resistive Load Usage Only



This product is not for use with Inductive loads. Inductive loads may create nuisance tripping of the Ground-Fault Equipment Protection circuit.

## Abnormal Odor or Smoke



In the event of smoke or a burning or abnormal odor, immediately interrupt power to the unit by turning off the circuit breaker protecting the unit.

## Electrical Shock / Fire Hazard



Any installation involving electric heater wiring must be grounded to earth to protect against shock and fire hazard. Suitable ground fault detection and interrupting systems must be in use at all times to reduce shock and fire hazard and to protect equipment.



Electric wiring to heating elements must be installed in accordance with National Electrical Code (NEC)/Canadian Electrical Code requirements, as well as all other local and applicable electrical codes and any thirdparty standards. This product is intended for commercial and industrial applications. Follow the installation instructions contained in this manual and those provided by the heater manufacturer.

Size the circuit breaker appropriately for the expected load and inrush current. The maximum rated current for the FPT 130 is 30 amps with resistive load.

Heater loads and their controls should not share a circuit branch with other types of equipment. A shared circuit may result in electromagnetic interference that can affect system operation.

Make certain that the heater shield is properly grounded. Failure to do so may result in damage to the equipment or fire.

**Following installation and prior to beginning system operation, refer to and perform the Post-Installation Test described in this manual.**

## CONTACTING CUSTOMER SERVICE

For assistance, contact Customer Service. Office hours are from 8:00 AM until 5:00 PM ET.

**Email:** [info@networketi.com](mailto:info@networketi.com)

**Web:** [networketi.com](http://networketi.com)

**Mail:** ETI  
1850 North Sheridan Street  
South Bend, IN 46628

## LIMITED WARRANTY

ETI's two year limited warranty covering defects in workmanship and materials applies. Contact Customer Service for complete warranty information.

## DISCLAIMER

ETI makes no representations or warranties, either expressed or implied, with respect to the contents of this publication or the products that it describes, and specifically disclaims any implied warranties of merchantability or fitness for any particular purpose. ETI reserves the right to revise this publication, and to make changes and improvements to the products described in this publication, without the obligation of ETI to notify any person or organization of such revisions, changes or improvements.

# QUICK-REFERENCE INSTALLATION GUIDE

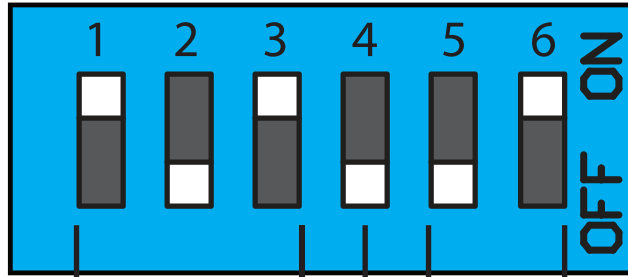

Default settings

## Temperature Sensor Fault Mode

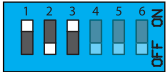

Energize Heaters if the sensor fails

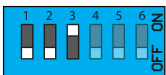

De-energize Heaters if the sensor fails

## Fire Protection Mode



Fire Protection ON



Fire Protection OFF

## Temperature Setpoint

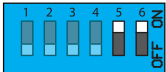

50 °F

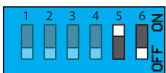

45 °F

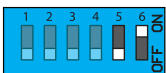

38 °F

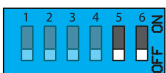

30 °F

**Note:** The DIP switches are read at power-up. If any DIP switch is changed while the unit is on, then the power needs to be turned off and on again for the new setting to take effect.

FPT130 Thermistor Fault				Fire Prot	FPT130 SET POINT			
Heat On	1	0	1		1	1	50F	
Heat Off	0	0	1	Lock	1	0	45F	
GPT RTD	4 wire	0	0		1	0	1	38F
	3 wire	0	1		0	0	0	30F
2 wire	1	1	0	0	0	0	30F	